

Stock Flexible Couplings



TBH



TBF



**Bored-To-Size
And Stock Bore**



**QD
Bushed**

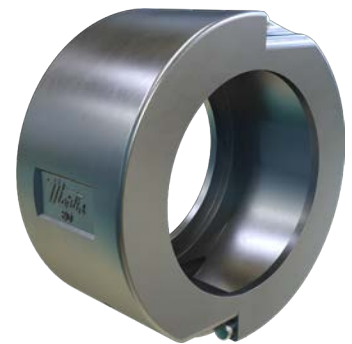

Covers

Stock Flexible Couplings



Bored-to-Size Couplings with Finished Bore, Keyway, and Set Screw

Coupling Number	Stock Finished Bores Include Standard Keyway and Setscrew	A	B	C	L	Coupling O.D.	Weight (lb)
4012	0.500, 0.625, 0.750, 1.406, 1.125, 0.281, 2.531, 2.406	1.406	1.125	0.281	2.531	2.406	.4
4016	0.625, 0.750, 0.875, 0.938, 1.000, 1.125, 1.188, 1.250, 1.969, 1.125, 0.281, 2.531, 3.031	1.969	1.125	0.281	2.531	3.031	.8
5016	0.750, 0.875, 1.000, 1.125, 1.188, 1.250, 1.375, 1.438, 1.500, 1.625, 2.500, 1.438, 0.375, 3.250, 3.781	2.500	1.438	0.375	3.250	3.781	1.6
5018	0.750, 0.875, 1.000, 1.125, 1.188, 1.250, 1.375, 1.438, 1.500, 1.625, 1.750, 1.875, 1.938, 2.969, 1.688, 0.375, 3.750, 4.188	2.969	1.688	0.375	3.750	4.188	2.4
6018	1.000, 1.125, 1.188, 1.250, 1.375, 1.438, 1.500, 1.625, 1.750, 1.875, 1.938, 2.000, 2.125, 2.188, 2.250, 2.375, 2.438, 3.500, 1.875, 0.438, 4.188, 5.000	3.500	1.875	0.438	4.188	5.000	4.8
6020	1.125, 1.250, 1.500, 1.750, 1.938, 2.125, 2.375, 2.438, 2.625, 3.875, 2.000, 0.438, 4.438, 5.500	3.875	2.000	0.438	4.438	5.500	5.2
6022	1.125, 1.750, 1.875, 1.938, 2.125, 2.375, 2.438, 2.625, 2.750, 2.875, 4.500, 2.125, 0.438, 4.688, 5.953	4.500	2.125	0.438	4.688	5.953	7.8
8018	1.125, 1.750, 1.938, 2.000, 2.125, 2.375, 2.438, 2.625, 2.875, 2.938, 4.563, 2.375, 0.578, 5.328, 6.656	4.563	2.375	0.578	5.328	6.656	9.5
8020	1.500, 2.188, 2.438, 2.688, 2.938, 3.125, 3.375, 3.438, 5.375, 2.625, 0.578, 5.516, 7.297	5.375	2.625	0.578	5.516	7.297	13.4
10018	1.500, 2.438, 2.875, 2.938, 3.438, 5.688, 2.750, 0.719, 6.219, 8.328	5.688	2.750	0.719	6.219	8.328	18.2
10020	2.000, 3.375, 3.688, 3.938, 6.719, 3.125, 0.719, 6.969, 9.125	6.719	3.125	0.719	6.969	9.125	25.0
12018	3.438, 3.938, 4.438, 6.750, 3.500, 0.859, 7.875, 10.000	6.750	3.500	0.859	7.875	10.000	28.0
12022	4.375, 4.438, 4.938, 8.750, 4.000, 0.859, 8.875, 11.891	8.750	4.000	0.859	8.875	11.891	55.0

CAUTION: All rotating power transmission products are potentially dangerous and must be properly guarded for the speeds and applications for which they were intended.

QD Couplings

Coupling Number	Bushing Used	Max. Bore**	A	B	D	C	L	Coupling O. D.	K†	Weight (lb)
4016JA	JA	1.000	2.000	0.875	1.313	0.281	2.906	3.031	1.250	0.9
5018SH	SH	1.375	2.969	1.000	1.500	0.375	3.375	4.188	1.750	1.3
6020SK	SK	2.125	3.875	1.250	1.875	0.438	4.188	5.500	2.250	2.5
8018SF	SF	2.313	4.563	1.750	2.375	0.578	5.328	6.656	2.250	5.3

** Maximum bore shown is the maximum bore with standard keyway. It is recommended that this maximum not be exceeded in both halves of a coupling.

† Minimum clearance required to remove the coupling half by using the screws as jack screws.

Taper Bushed Couplings Type

Type TBH	Type TBF	Bushing Data			A	B	C	J*	K†	L	OD	Weight (lb)
Coupling Number	Coupling Number	Bushing Used	Max. Bore	Min. Bore								
4016TBH	4016TBF	1108	1.125	0.500	1.969	0.875	0.281	0.625	0.750	2.031	3.031	0.9
5018TBH	5018TBF	1610	1.625	0.500	2.969	1.000	0.375	0.813	1.167	2.375	4.188	1.1
6020TBH	6020TBF	2012	2.000	0.500	3.875	1.250	0.438	0.938	1.375	2.938	5.500	2.7
8020TBH	8020TBF	3020	3.000	0.938	5.375	2.000	0.578	1.188	2.167	4.578	7.297	6.1
10020TBH	10020TBF	3535	3.500	1.188	6.719	3.500	0.719	2.000	2.625	7.719	9.125	19.0

** Space needed for (1) tightening bushing with shortened hex key (2) loosening screws for puller to remove hub.

† Minimum clearance required to remove the coupling half by using the screws as jack screws with shortened hex key.

Our High-Speed Standard Covers Fit These Couplings

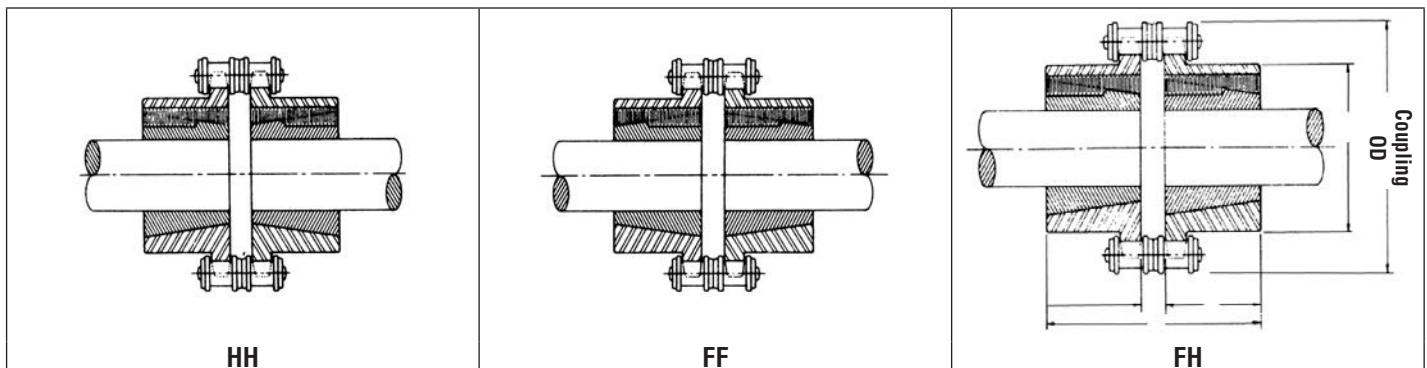

All Martin chain couplings have hardened teeth

Coupling Selection

Roller chain couplings have a torque capacity in excess of the torque normally transmitted by shafting which falls within the coupling bore range. Select the smallest coupling which will accommodate both shafts. For a reversing operation, shock or pulsating loads, or other severe operating conditions, select the next larger coupling size.

A cover should be used to assure maximum service life, particularly if the coupling operates at high speeds or under moist conditions. For proper lubrication, fill the space between the cover and the coupling with soft to medium consistency coupling grease.

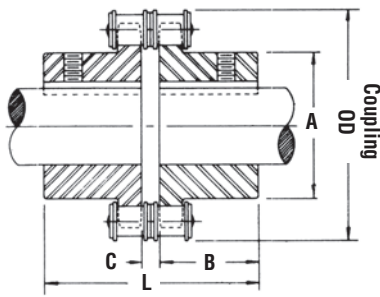

BS Coupling

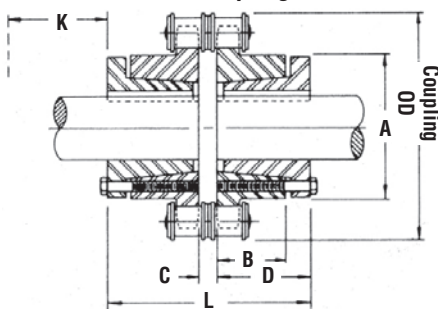

QD Coupling



Type TBF



Type TBH

Coupling with Plain Bores for Reboring

Coupling Number	Maximum Bore Inches	Minimum Plain Bore Inches	Weight (lb)	Recommended Maximum RPM	Coupling Chain Number	Weight (lb)
4012	0.875	0.438	0.5	5000	4012 CHN	0.4
4016	1.313	0.625	1.0	5000	4016 CHN	0.5
5016	1.688	0.625	2.2	4000	5016 CHN	1.2
5018	2.000	0.750	3.5	3600	5018 CHN	1.3
6018	2.438	1.000	5.0	3000	6018 CHN	2.2
6020	2.750	1.125	6.5	2500	6020 CHN	2.6
6022	3.000	1.125	9.4	2500	6022 CHN	2.7
8018	3.125	1.125	11.0	2000	8018 CHN	5.3
8020	3.563	1.500	16.3	2000	8020 CHN	5.9
10018	3.875	1.500	20.3	1800	10018 CHN	9.8
10020	4.625	1.500	31.8	1800	10020 CHN	10.9
12018	4.688	2.000	36.8	1500	12018 CHN	17.3
12022	6.125	2.000	70.0	1200	12022 CHN	21.2

Stock Coupling Covers

Covers fit taper bushed, QD and stock, and finished bore couplings. Covers allow excellent lubrication, and their use is recommended to obtain maximum coupling life. Covers are of aluminum or plastic, and are made in halves for easy installation. Synthetic rubber oil seals, which contact the coupling hubs, retain the lubricant and prevent the entry of dirt. Covers are fitted with gaskets between the halves.

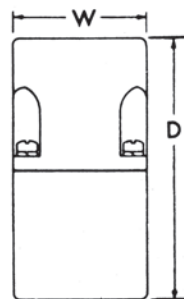
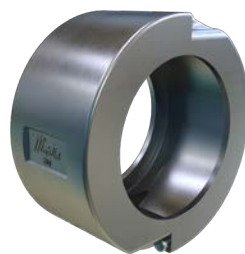

Aluminum and Plastic

Cover Cat. No.	Aluminum		Plastic		Weight (lb)
	D	W	D	W	
4012COV**	4.000	2.000	4.000	2.313	0.8
4016COV**	4.000	2.000	4.000	2.313	0.9
5016COV**	5.125	2.375	5.125	2.625	1.3
5018COV**	5.125	2.375	5.125	2.625	1.3
6018COV**	6.375	2.938	6.375	3.167	2.4
6020COV**	6.375	2.938	6.375	3.167	2.4
6022COV*	8.188	4.000	8.188	4.000	4.9
8018COV	8.188	4.000	8.188	4.000	4.9
8020COV	8.188	4.000	8.188	4.000	4.9
10018COV	9.375	5.938	9.375	5.938	8.8
10020COV	10.125	5.250	10.125	5.250	12.7
12018COV	11.375	7.375	11.375	7.375	16.5
12022COV	13.250	7.938	13.250	7.938	19.5

* Use 8018 cover — Special Seals Available
 ** Furnished in Plastic unless specified with AL Suffix when ordering.