

BUJES DE FIJACIÓN LD

Los bujes LD se fabrican con un anillo interior y otro exterior desmontable, y una tuerca hexagonal, que al girar introduce el anillo interior produciendo el bloqueo de eje y cubo.

VENTAJAS DEL BUJE LD RESPECTO AL SISTEMA CONVENCIONAL

- **Facilidad de montaje y desmontaje**, con una sola operación de girar la tuerca se instala, a diferencia del sistema multituerca.
- **Fácil posicionamiento**, es autocentrante ya que su longitud axial es mayor que el diámetro exterior lo cual permite una mayor tolerancia de mecanización.
- **Protección contra sobrecargas**, por su diseño la fuerza de expansión es perpendicular al eje, lo que facilita un par de apriete regular.
- **Aplicaciones ilimitadas**, el sistema LD es indicado para cualquier fijación de elementos sobre un eje, no resultando afectados por temperaturas de -30° a 200°C .

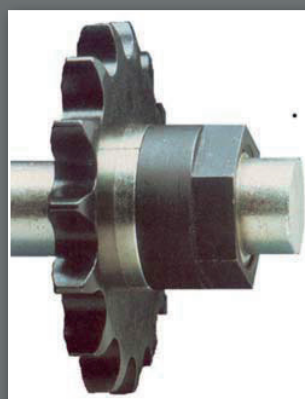
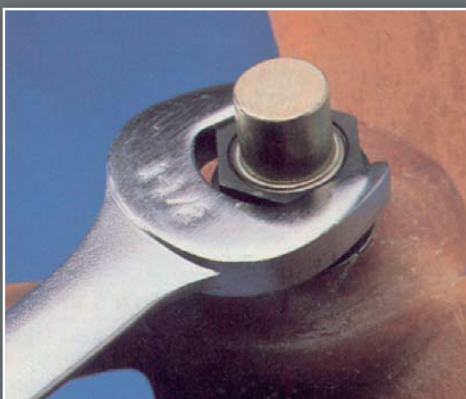
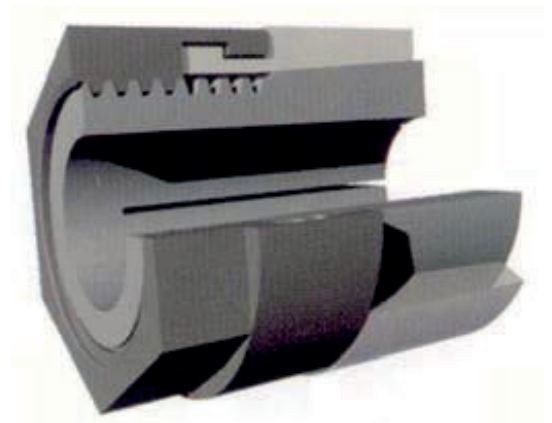
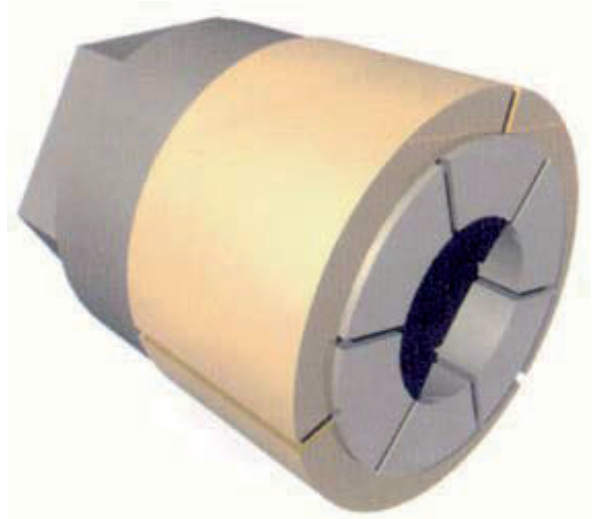

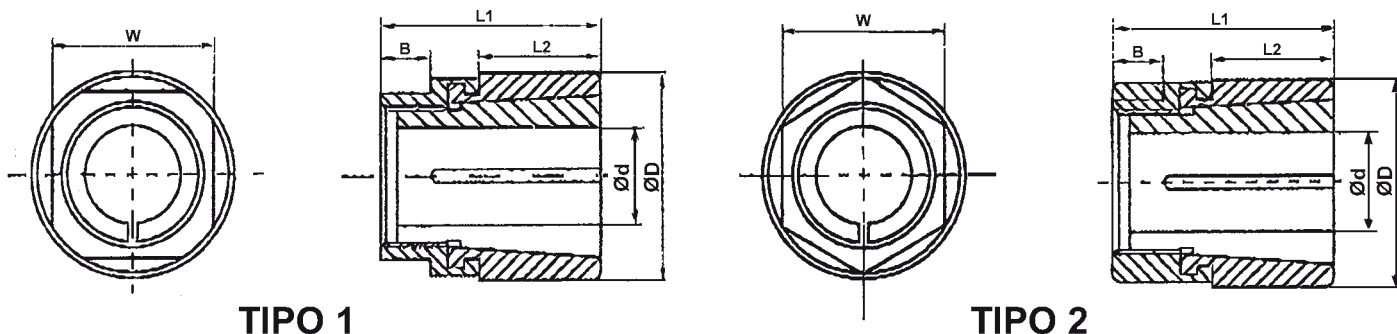

TIPO 1

TIPO 2

Catálogo	Dimensiones							Rendimiento		PAR apriete Tuerca N.M	Presión sobre Cubo N/Cm ²	Peso Kg
	d	D	TIPO	L1	L2	W	B	PAR Max. N.M	Esfuerzo Axial MAX. Kgf.M			
LD5	5	16	1	19	9.5	13	3	12	323	14.1	3585	0.014
LD6	6							16	348			
LD8	8	19	1	22	11	16	3	23	405	17.0	2550	0.028
LD9	9							26	414			
LD10	10	22.5	1	25.5	12.5	19	5	30	425	19.8	1860	0.042
LD11	11							34	433			
LD12	12							39	439			
LD14	14	25.5	1	28.5	16	22	5	44	449	22.6	1240	0.056
LD15	15							45	451			
LD16	16							50	453			
LD17	17	38	2	38	19	32	8	220	1700	136	7590	0.23
LD18	18							265	1845			
LD19	19							282	1990			
LD20	20	45	2	47.5	21.5	38	11	290	2140	170	6480	0.31
LD22	22							315	2456			
LD24	24							380	2773			
LD25	25							390	2926			
LD28	28	51	2	57	25.5	46	13	495	3323	225	5380	0.51
LD30	30							580	3600			
LD32	32							680	3894			
LD34	34	60.5	2	70	38	50	14	710	4180	260	4480	0.77
LD35	35							725	4322			
LD36	36							750	4465			
LD38	38							790	4750			
LD40	40	67	2	79.5	43	60	14.5	900	5066	316	3790	1.05
LD42	42							1000	5433			
LD45	45	73	2	90.5	51	65	16	1175	5860	441	2900	1.36
LD48	48							1355	6417			
LD50	50							1510	6700			
LD55	55	80	2	95	54	70	16	1650	6900	600	2400	2.13
LD60	60	86	2	98.5	57	75	17.5	1740	7000	634	1930	2.27
LD65	65	92	2	103	60.5	80	17.5	1830	7090	679	1660	2.68
LD70	70							1920	7190			
LD75	75	100	2	108	63.5	90	19	2000	7300	750	1600	2.72