

ACOPLAMIENTOS ELÁSTICOS



Martin

RAIHI[®]

Lovejoy[®]



Acoplamiento apto para atmósferas explosivas
Certificado según la Directiva 94/9/CE

Ideal para motores eléctricos y construcción de máquinas.



ELEMENTO ELÁSTICO

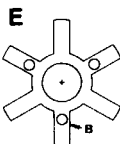

Tipo estandar "E":
Forma de estrella

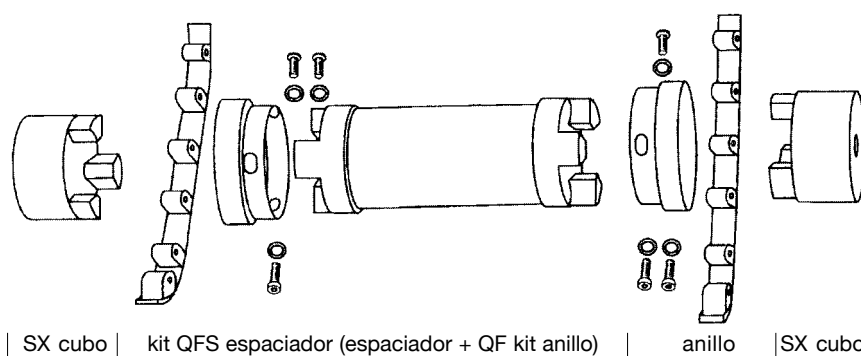

Tipo Anillo "QF":
NBR-URETANO-HYTREL de Martin con aro metálico atornillados en los cubos.

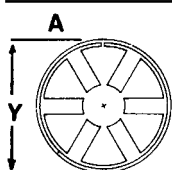

Tipo anillo "A": Forma de **anillo** que se mantiene cerrado con un muelle y en caso de deterioro del elemento elástico los cubos mantienen la transmisión.



Tipo Anillo "IN-SHEAR": De uretano abierto que se mantiene cerrado con un aro metálico y en caso de deterioro del elemento elástico los dientes de los cubos no están superpuestos.

Materiales:

NBR: Color negro, caucho nitrilo butadieno, elástico.

HYTREL: Color azul, menos elástico y más resistente.

URETANO: Color gris - naranja, buena resistencia química.

BRONCE: impregnado en aceite, antideflagrante, rígido.

Tipo	Temperatura	Dureza Shore	Elasticidad	Desalineaciones		Resistencia		Factor de Par
				ang. grados	paral. mm.	aceite	química	
NBR	-40 +100 C	80 ShA	++	1	0,38	+	+	1
URETANO	-34 +71 C	90 ShA	+	1	0,38	++	+	1,5
HYTREL	-51 +121 C	55ShD	+	0,5	0,38	++	++	3
BRONCE	-40 +232 C	rígido	0	0,5	0,25	+++	++	3 máx. 250 rpm.

0 = Baja

+ = Regular

++ = Buena

+++ = Excelente

Otros materiales sobre demanda:

Acero inoxidable (resistente a la corrosión)

Bronce (anticorrosión - antideflagrante)

Fundición (tamaños L. 190 - L. 225)

Aluminio (ligero - baja inercia)

Acero (posibilidad de soldadura)



Los acabados son cubos simétricos y con agujeros H7, chavetero standard y prisioneros. Espaciadores de aluminio. La superficie de los cubos Martin es pavonada en color azul.

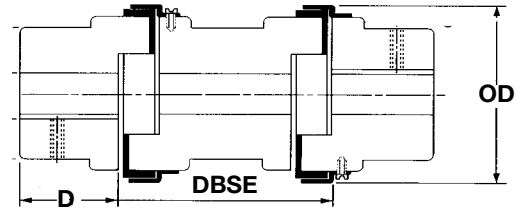
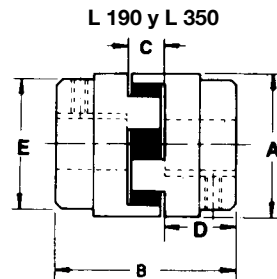
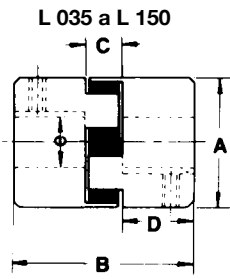

DBSE - 100 mm - 140 mm - 180 mm
QFS (2 cubos + 1 kit de anillo QF + 1 kit espaciador QFS)

CARACTERÍSTICAS Y DIMENSIONES EN MM							PAR NOMINAL Nm		
Tipo	A	OD	B	D	E	Máx. agujero	E + A	U	H
							NBR	URETANO	HYTREL
L. 035	15,9	-	20,6	6,7	15,9	10	0,46	0,60	1
L. 050	27,4	-	43,6	15,9	27,4	16	4	6	11
L. 070	34,5	-	50,8	19,1	34,5	19	6	8	14
L. 075	44,5	-	54,0	20,6	44,5	24	12	15	27
L. 090	53,6	65	54,0	20,6	53,6	25	20	32	47
L. 095	53,6	65	63,5	25,4	53,6	28	26	32	64
L. 100	64,3	78	89,0	34,9	64,3	35	47	70	141
L. 110	84,1	96	108,0	42,9	84,1	42	89	134	256
L. 150	95,3	111	114,3	44,4	95,3	48	141	212	405
L. 190	114,3	129	123,8	49,2	101,6	55	190	285	512
L. 225	127,0	142	136,5	55,6	108,0	65	265	398	768
L. 276	-	173	200	80	127	75	532	798 (E)	1330 (QF)
L. 295	-	253	238	95	162	95	1279	1919 (E)	3197 (QF)
L. 2955	-	253	264	108	180	105	2132	3198 (E)	5330 (QF)
L. 300	-	272	283	115	180	105	3047	4570 (E)	7617 (QF)
L. 350	-	323	309	128	200	115	4308	6462 (E)	10770 (QF)

(E) Acabado forma estrella Uretano (Modelos L. 276 a L. 350)

(QF) Acabado forma Hytrel (Modelos L. 276 a L. 350)

Programa de fabricación de cubos mecanizados

Disponibles mecanizados en pulgadas

○ Agujero acabado + chavetero + tornillos prisioneros

● Agujero acabado sin chavetero

Tipo	6	8	9	10	11	12	14	15	16	17	18	19	20	22	24	25	28	30	32	35	38	40	42	45	48	50	55	60	65	Diámetro agujero	
035	●	●																													
050	●	●	○	○	○	○	○	○	○																						
070				○	○	○	○	○	○	○	○																				
075				○	○	○	○	○	○	○	○	○	○																		
090				○																											
095						○	○	○	○	○	○	○	○	○																	
100																															
110																															
150																															
190																															
225																															

Indicar en el pedido los agujeros de cada uno y la estrella elegida.

El acoplamiento CJ es ideal por su diseño, peso, bajos momentos de inercia y transmisión de par elevado en montajes, tanto en posición vertical como horizontal.

Materiales utilizados y acabados

- Fundición
- Aluminio
- Acero sinterizado
- Cubos mecanizados
- Cubos taper

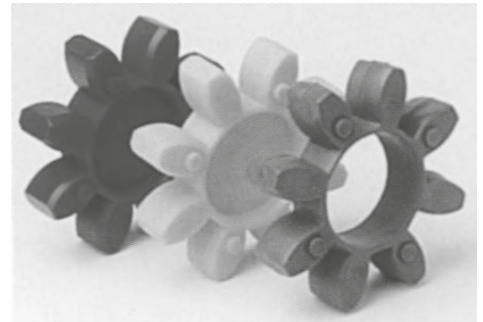

Elementos elásticos de poliuretano:

Tipo Estrella	Color	Temperatura		Desalineamiento		
		Normal	Máxima	Angular	Paralelo	Axial
80 Shore A	Azul	-40 a 80 C	-60 a 80 C	.9 - 1.3 deg	.2 - .6 mm	.6 - 4.6 mm
92 Shore A	Blanco Amarillo	-40 a 90 C	-40 a 120 C	.9 - 1.3 deg	.2 - .6 mm	.6 - 4.6 mm
98 Shore A	Rojo	-30 a 100 C	-40 a 120 C	.9 - 1.3 deg	.2 - .6 mm	.6 - 4.6 mm
64 Shore D	Verde	-20 a 100 C	-30 a 120 C	.9 - 1.3 deg	.2 - .6 mm	.6 - 4.6 mm

Programa de fabricación de cubos mecanizados:

Tipo	Cubo	Eje. mec.	Diámetro Agujero H7 + Chavetero																																		
			6	8	9	10	11	12	14	15	16	18	19	20	22	24	25	28	30	32	35	38	40	42	45	48	50	55	60	65	70	75	80	85	90		
14/16	B	•		•	•	•	•	•																													
19/24	A	•				•	•	•	•	•	•																										
19/24	B	•																																			
24/32	A	•																																			
24/32	B	•																																			
28/38	A	•																																			
28/38	B	•																																			
38/45	A	•																																			
38/45	B	•																																			
42/55	A	•																																			
42/55	B	•																																			
48/60	A	•																																			
48/60	B	•																																			
55/70	A	•																																			
55/70	B	•																																			
65/75	A	•																																			
65/75	B	•																																			
75/90	A	•																																			
75/90	B	•																																			
90	A	•																																			

Cubos en fundición GG25 ó Acero sinterizado • Cubo tipo A o B en stock

SERIE TAPER

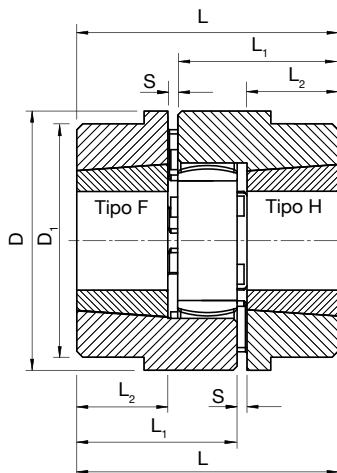

Tipo	Velocidad Máxima rev/min	Par nominal			Taper N°	Agujero Máx.	D	D ₁	S	L ₁	L ₂	L
		92 ShA Nm	98 ShA Nm	64 ShD Nm								
24 F	14000	35	60	75	1008	25	56	-	1.0	39.0	23.0	63.0
H					1008	25	56	-	1.0	39.0	23.0	63.0
28 F	11800	95	160	200	1108	28	65	-	1.5	40.5	23.0	65.0
H					1108	28	65	-	1.5	40.5	23.0	65.0
38 F	9500	190	325	405	1108	28	80	78	1.0	44.0	23.0	68.0
H					1108	28	80	78	1.0	44.0	23.0	68.0
42 F	8000	265	450	560	1610	42	95	94	1.0	49.0	26.0	76.0
H					1610	42	95	94	1.0	49.0	26.0	76.0
48 F	7100	310	525	655	1615	42	105	104	1.5	63.5	39.0	104.0
H					1615	42	105	104	1.5	63.5	39.0	104.0
55 F	6300	410	685	825	2012	50	120	118	2.0	59.0	33.0	94.0
H					2012	50	120	118	2.0	59.0	33.0	94.0
65 F	5600	625	940	1175	2012	50	135	133	1.5	63.5	33.0	98.0
H					2517	65	135	133	1.5	75.5	45.0	122.0
75 F	4750	1280	1920	2350	2517	65	160	135	1.0	81.0	46.0	128.0
H					3020	75	160	135	1.0	87.0	52.0	140.0
90 F	3750	2400	3600	4800	3020	75	200	160	1.5	91.5	52.0	145.0
H					3525	100	200	160	1.5	103.5	64.0	169.0

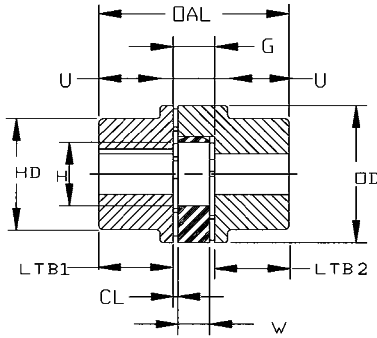

Configuración "AA"



Acoplamiento CJ de Lovejoy

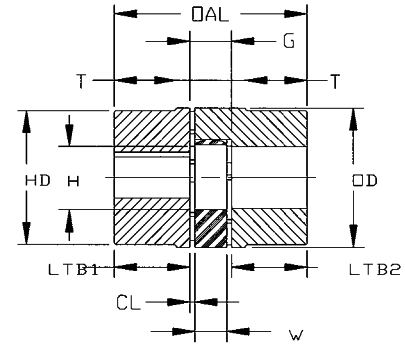

Configuración "BB"

Tipo	Cubo	Fundición		LTB1 Y LTB2	G	CL	W	OAL	T;U	OD	H	Par Nominal (Nm)		
		Ø Min/Max	HD									92 ShA	98 ShA	64 ShD
14 *	B	S-16	-	11	13	1,5	10	35		30	10	7,5	12,5	-
	BX	S-16	-	18,5	13	1,5	10	50		30	10			
19/24	A	S-19	32	25	16	2	16	66	20	40	18	10	17	-
	BX	S-24	-	55	16	2	16	126		40	18			
24/32	A	S-24	40	30	18	2	18	78	24	56	27			
	B	S-32	-	30	18	2	18	78		56	27	35	60	75
	BX	S-32	-	60	18	2	18	138		56	27			
28/38	A	S-28	48	35	20	2,5	20	90	28	65	30			
	B	11-38	-	35	20	2,5	20	90		65	30	95	160	200
	BX	S-38	-	80	20	2,5	20	180		65	30			
38/45	A	S-38	66	45	24	3	24	114	37	80	38			
	B	12-45	-	45	24	3	24	114		80	38	190	325	405
	BX	S-45	-	80-110	24	3	24	184 - 244		80	38			
42/55	A	S-42	75	50	26	3	26	126	40	95	46			
	B	36-55	-	50	26	3	26	126		95	46	265	450	560
	BX			110	26	3	26	246		95	46			
48/60	A	S-48	85	56	28	3,5	28	140	45	105	51			
	B	42-60	-	56	28	3,5	28	140		105	51	310	525	655
	BX			110	28	3,5	28	248		105	51			
55/70	A	S-55	98	65	30	4	30	160	52	120	60			
	B	49-70	-	65	30	4	30	160		120	60	410	685	825
	BX			140	30	4	30	310		120	60			
65/75	A	S-65	115	75	35	4,5	35	185	47	135	68			
	B	59-75	-	75	35	4,5	35	185		135	68	625	940	1175
	BX			140	35	4,5	35	235		135	68			
75/90	A	S-75	135	85	40	5	40	210	53	160	80			
	B	52-90	-	85	40	5	40	210		160	80	1280	1920	2350
90/100	A	S-90	160	100	45	5,5	45	245	62	200	100			
	B	81-100	-	100	45	5,5	45	245		200	100	2400	3600	4800
100 **	B	42-100	200	110	50	6	50	270		225	113	3300	4950	9000
110 **	B	62-125	230	120	55	6,5	55	295		255	127	4800	7200	
125 **	B	12-145	265	140	60	7	60	340		290	147	6650	10000	

BX = Cubo largo

* Acero sinterizado

** Fundición Nodular (GGG)

Otros acabados

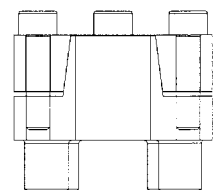
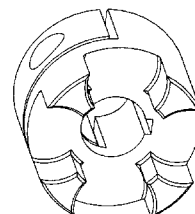
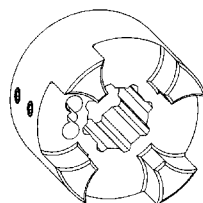
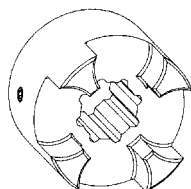
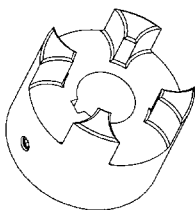

El acoplamiento Martinflex es ideal para absorber vibraciones, choques y sacudidas bruscas, permitiendo ciertos niveles de desalineación.

CARACTERÍSTICAS

- Desalineaciones axiales, radiales y angulares.
- Gran torsión elástica.
- Fácil montaje
- Fijación con casquillo cónico
- Absorción de vibraciones y oscilaciones

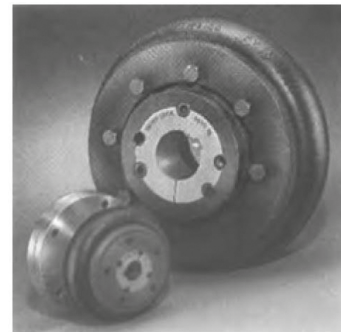

CARACTERÍSTICAS FÍSICAS DE LAS CUBIERTAS FLEXIBLES

Características	TIPO DE ACOPLAMIENTO														
	F40	F50	F60	F70	F80	F90	F100	F110	F120	F140	F160	F180	F200	F220	F250
Velocidad máx. rev/min.	4500	4500	4000	3600	3100	3000	2600	2300	2050	1800	1600	1500	1300	1100	1000
Par nominal Nm Tkn	24	66	127	250	375	500	675	875	1330	2325	3770	6270	9325	11600	14675
Par max. Nm Tk máx.	64	160	318	487	759	1096	1517	2137	3547	5642	9339	16455	23508	33125	42740
Ángulo de torsión Nm/°	5	13	26	41	63	91	126	178	296	470	778	1371	1959	2760	3562
Desalineamiento máx.	1,1	1,3	1,6	1,9	2,1	2,4	2,6	2,9	3,2	3,7	4,2	4,8	5,3	5,8	6,6
Masa aproximada Kg.	0,1	0,3	0,5	0,7	1,0	1,1	1,1	1,4	2,3	2,6	3,4	7,7	8,0	10	15
Par alternativo +- Nm 10Hz Tkw	11	26	53	81	127	183	252	356	591	940	1556	2742	3918	5521	7124
Factor de resonancia V	7	7	7	7	7	7	7	7	7	7	7	7	7	7	7
Coefficiente de amortiguación	0,9	0,9	0,9	0,9	0,9	0,9	0,9	0,9	0,9	0,9	0,9	0,9	0,9	0,9	0,9

VALORES DE POTENCIA (Kw)

Velocidad rev/min.	TIPO DE ACOPLAMIENTO														
	F40	F50	F60	F70	F80	F90	F100	F110	F120	F140	F160	F180	F200	F220	F250
100	0,25	0,69	1,33	2,62	3,93	5,24	7,07	9,16	13,9	24,3	39,5	65,7	97,6	121	154
200	0,50	1,38	2,66	5,24	7,85	10,5	14,1	18,3	27,9	48,7	79,0	131	195	243	307
300	0,75	2,07	3,99	7,85	11,8	15,7	21,2	27,5	41,8	73,0	118	197	293	364	461
400	1,01	2,76	5,32	10,5	15,7	20,9	28,3	36,6	55,7	97,4	158	263	391	486	615
500	1,26	3,46	6,65	13,1	19,6	26,2	35,3	45,8	69,6	122	197	328	488	607	768
600	1,51	4,15	7,98	15,7	23,6	31,4	42,4	55,0	83,6	146	237	394	586	729	922
700	1,76	4,84	9,31	18,3	27,5	36,6	49,5	64,1	97,5	170	276	460	684	850	1076
720	1,81	4,98	9,57	18,8	28,3	37,7	50,9	66,0	100	175	284	473	703	875	1106
800	2,01	5,53	10,6	20,9	31,4	41,9	56,5	73,3	111	195	316	525	781	972	1229
900	2,26	6,22	12,0	23,6	35,3	47,1	63,6	82,5	125	219	355	591	879	1093	1383
960	2,41	6,63	12,8	25,1	37,7	50,3	67,9	88,0	134	234	379	630	937	1166	1475
1000	2,51	6,91	13,3	26,2	39,3	52,4	70,7	91,6	139	243	395	657	976	1215	1537
1200	3,02	8,29	16,0	31,4	47,1	62,8	84,8	110	167	292	474	788	1172		
1400	3,52	9,68	18,6	36,6	55,0	73,3	99,0	128	195	341	553	919			
1440	3,62	9,95	19,1	37,7	56,5	75,4	102	132	201	351	568	945			
1600	4,02	11,1	21,3	41,9	62,8	83,8	113	147	223	390	632				
1800	4,52	12,4	23,9	47,1	70,7	94,2	127	165	251	438					
2000	5,03	13,8	26,6	52,4	78,5	105,5	141	183	279						
2200	5,53	15,2	29,3	57,6	86,4	115	155	202							
2400	6,03	16,6	31,9	62,8	94,2	126	170								
2600	6,53	18,0	34,6	68,1	102	136	184								
2800	7,04	19,4	37,2	73,3	110	147									
2880	7,24	19,9	38,3	75,4	113	151									
3000	7,54	20,7	39,9	78,5	118	157									
3600	9,05	24,9	47,9	94,2											

Las figuras en tipo pesado son para motores de velocidad estandar. Todos estos valores de potencia han sido calculados a par constante. Para velocidades inferiores a 100 rev/min. e intermedias usar el par nominal.

DIMENSIONES

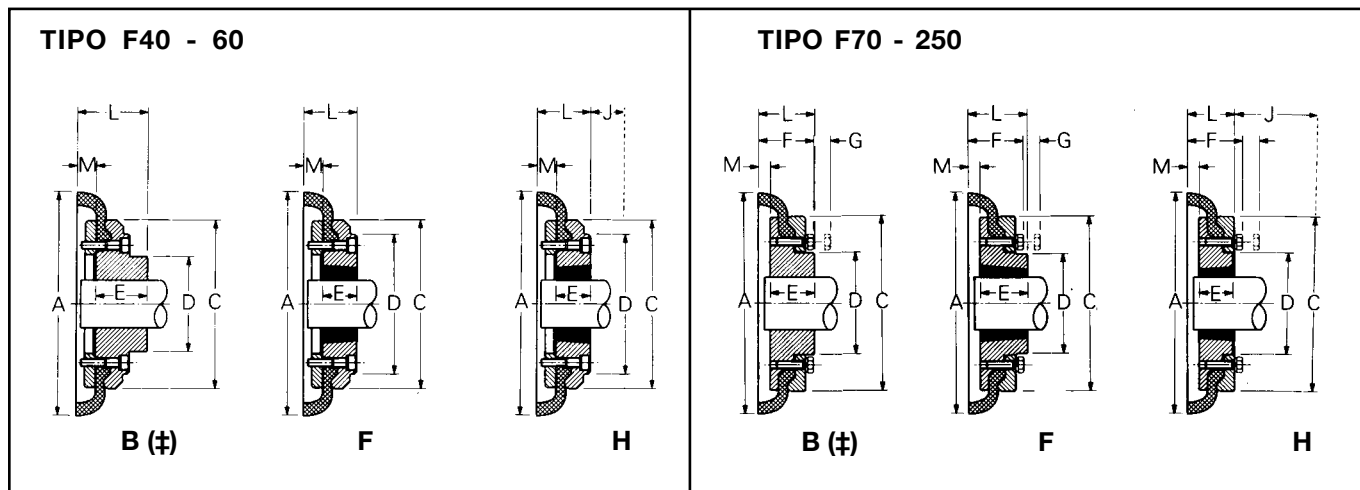

CARACTERÍSTICAS DE LOS ACOPLAMIENTOS MARTINFLEX TIPOS B, F & H.

Tipo	Tipo S/MONTA.	TAPER N.º	Max. Agujero		Tipos F & H			Tipo B		Tuerca	A	C	D	F	G	M	Masa (kg)	Inercia* (kgm²)
			Métrico	Pulgadas	L	E	J	L	E									
F40	B	-	32	-	-	-	29	33	22	M5	104	82	-	-	-	11	0,8	0,00074
F40	F	1008	25	1"	33	22	29	-	-	-	104	82	-	-	-	11	0,8	0,00074
F40	H	1008	25	1"	33	22	29	-	-	-	104	82	-	-	-	11	0,8	0,00074
F50	B	-	38	-	-	-	38	45	32	M5	133	100	79	-	-	12,5	1,2	0,00115
F50	F	1210	32	1 1/4"	38	25	38	-	-	-	133	100	79	-	-	12,5	1,2	0,00115
F50	H	1210	32	1 1/4"	38	25	38	-	-	-	133	100	79	-	-	12,5	1,2	0,00115
F60	B	-	45	-	-	-	38	55	38	M6	165	125	70	-	-	16,5	2,0	0,0052
F60	F	1610	42	1 5/8"	42	25	38	-	-	-	165	125	103	-	-	16,5	2,0	0,0052
F60	H	1610	42	1 5/8"	42	25	38	-	-	-	165	125	103	-	-	16,5	2,0	0,0052
F70	B	-	50	-	-	-	-	47	35	M10	187	144	80	50	13	11,5	3,1	0,009
F70	F	2012	50	2"	44	32	42	-	-	-	187	144	80	50	13	11,5	3,1	0,009
F70	H	1610	42	1 5/8"	42	25	38	-	-	-	187	144	80	50	13	11,5	3,0	0,009
F80	B	-	65	-	-	-	-	55	42	M10	211	167	97	54	16	12,5	4,9	0,018
F80	F	2517	65	2 1/2"	58	45	48	-	-	-	211	167	95	54	16	12,5	4,9	0,018
F80	H	2012	50	2"	45	32	42	-	-	-	211	167	97	54	16	12,5	4,6	0,017
F90	B	-	70	-	-	-	-	63,5	49	M12	235	188	112	60	16	13,5	7,1	0,032
F90	F	2517	65	2 1/2"	59,5	45	48	-	-	-	235	188	108	60	16	13,5	7,0	0,031
F90	H	2517	65	2 1/2"	59,5	45	48	-	-	-	235	188	108	60	16	13,5	7,0	0,031
F100	B	-	80	-	-	-	-	70,5	56	M12	254	216	125	62	16	13,5	9,9	0,055
F100	F	3020	75	3"	65,5	51	55	-	-	-	254	216	120	62	16	13,5	9,9	0,055
F100	H	2517	65	2 1/2"	59,9	45	48	-	-	-	254	216	113	62	16	13,5	9,4	0,054
F110	B	-	90	-	-	-	-	75,5	63	M12	279	233	128	62	16	12,5	12,5	0,081
F110	F	3020	75	3"	63,5	51	55	-	-	-	279	233	134	62	16	12,5	11,7	0,078
F110	H	3020	75	3"	63,5	51	55	-	-	-	279	233	134	62	16	12,5	11,7	0,078
F120	B	-	100	-	-	-	-	84,5	70	M16	314	264	143	67	16	14,5	16,9	0,137
F120	F	3525	100	4"	79,5	65	67	-	-	-	314	264	140	67	16	14,5	16,5	0,137
F120	H	3020	75	3"	65,5	51	55	-	-	-	314	264	140	67	16	14,5	15,9	0,130
F140	B	-	130	-	-	-	-	110,5	94	M20	359	311	178	73	17	16	22,2	0,254
F140	F	3525	100	4"	81,5	65	67	-	-	-	359	311	178	73	17	16	22,3	0,255
F140	H	3525	100	4"	81,5	65	67	-	-	-	359	311	178	73	17	16	22,3	0,255
F160	B	-	140	-	-	-	-	117	102	M20	402	345	187	78	19	15	35,8	0,469
F160	F	4030	115	4 1/2"	92	77	80	-	-	-	402	345	197	78	19	15	32,	0,380
F160	H	4030	115	4 1/2"	92	77	80	-	-	-	402	345	197	78	19	15	32,5	0,380
F180	B	-	150	-	-	-	-	137	114	M20	470	398	200	94	19	23	49,1	0,871
F180	F	4535	125	5"	112	89	89	-	-	-	470	398	205	94	19	23	42,2	0,847
F180	H	4535	125	5"	112	89	89	-	-	-	470	398	205	94	19	23	42,2	0,847
F200	B	-	150	-	-	-	-	138	114	M20	508	429	200	103	19	24	58,2	1,301
F200	F	4535	125	5"	113	89	89	-	-	-	508	429	205	103	19	24	53,6	1,281
F200	H	4535	125	5"	113	89	89	-	-	-	508	429	205	103	19	24	53,6	1,281
F220	B	-	160	-	-	-	-	154,5	127	M20	562	474	218	118	20	27,5	79,6	2,142
F220	F	5040	125	5"	129,5	102	92	-	-	-	562	474	223	118	20	27,5	72,0	2,104
F220	H	5040	125	5"	129,5	102	92	-	-	-	562	474	223	118	20	27,5	72,0	2,104
F250	B	-	190	-	-	-	-	161,5	132	M20	628	532	254	125	25	29,5	104,0	3,505

ESPACIADORES SERIE MARTIN-FLEX *Martin*

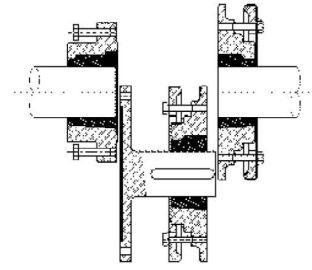
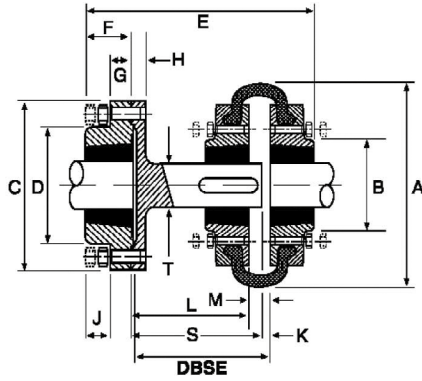

Tipo Espaciador	DBSE	Taper espaciador	Agujero máx. mm	Tipo Martin-Flex	Taper Martin-flex	Agujero máx. mm	A	B	C	D	E	F	G	H	J	K	L	M	S	T
SM12	80	1210	32	F40	1008	25	104	82	118	83	134	25	14	15	14	6	65	22	77	25
SM12	100	1210	32	F40	1008	25	104	82	118	83	140	25	14	15	14	22	77	22	77	25
SM16	100	1615	42	F40	1008	25	104	82	127	80	157	38	18	15	18	9	88	22	94	32
SM16	140	1615	42	F40	1008	25	104	82	127	80	187	38	18	15	18	9	128	22	134	32
SM16	100	1615	42	F50	1210	32	133	79	127	80	160	38	18	15	18	9	85	25	94	32
SM16	140	1615	42	F50	1210	32	133	79	127	80	200	38	18	15	18	9	125	25	134	32
SM16	100	1615	42	F60	1610	42	165	103	127	80	161	38	18	15	18	9	78	33	94	32
SM16	140	1615	42	F60	1610	42	165	103	127	80	201	38	18	15	18	9	118	33	134	32
SM25	100	2517	65	F70	2012	50	187	80	178	123	180	45	22	16	22	9	80	23	94	48
SM25	140	2517	65	F70	2012	50	187	80	178	123	220	45	22	16	22	9	120	23	174	48
SM25	180	2517	65	F70	2012	50	187	80	178	123	260	45	22	16	22	9	160	23	174	48
SM25	100	2517	65	F80	2517	60	211	95	178	123	193	45	22	16	22	9	78	25	94	48
SM25	140	2517	65	F80	2517	60	211	95	178	123	233	45	22	16	22	9	118	25	134	48
SM25	180	2517	65	F80	2517	60	211	95	178	123	273	45	22	16	22	9	158	25	174	48
SM25	140	2517	65	F90	2517	60	235	108	178	123	233	45	22	16	22	9	116	27	134	48
SM25	180	2517	65	F90	2517	60	235	108	178	123	273	45	22	16	22	9	156	27	174	48
SM30	140	3020	75	F100	3020	75	254	120	216	146	245	51	29	20	29	9	116	27	134	60
SM30	180	3020	75	F100	3020	75	254	120	216	146	285	51	29	20	29	9	156	27	174	60
SM30	140	3020	75	F110	3020	75	279	134	216	146	245	51	29	20	29	9	118	25	134	60
SM30	180	3020	75	F110	3020	75	279	134	216	146	285	51	29	20	29	9	158	25	174	60
SM35	140	3525	100	F120	3525	100	314	140	248	178	272	63	34	20	34	9	114	29	134	80
SM35	180	3525	100	F120	3525	100	314	140	248	178	312	63	34	20	34	9	154	29	174	80
SM35	140	3525	100	F140	3525	100	359	178	248	178	271	63	34	20	34	9	111	27	134	80
SM35	180	3525	100	F140	3525	100	359	178	248	178	312	63	34	20	34	9	151	27	174	80

Nota: Disponibles medidas mayores de espaciadores.

*F40 "B" la brida puede usarse para encajar el eje espaciador
 "F" la brida puede usarse para encajar el eje espaciador
 DBSE - distancia entre extremos del eje

ESPACIADORES SERIE HRC *Martin*

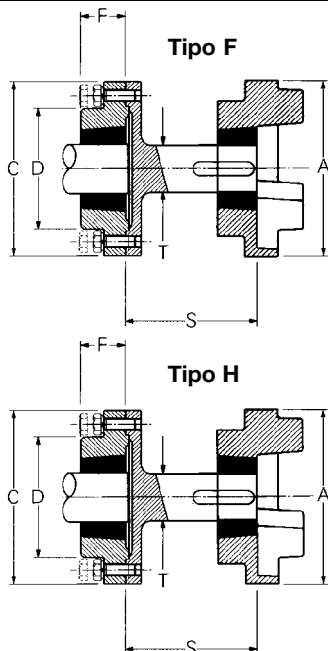

Tipo espaciador	Taper espaciador	Agujero máx. mm	Tipo HRC Tipo F ó H	Taper HRC	Agujero máx. mm	A	C	D	F	S	T
SM12-100	1210	32	HRC-110	1610	25	112	118	83	25	77	25
SM16-100	1615	42	HRC-130	1610	42	130	127	80	38	94	32
SM16-140	1615	42	HRC-130	1610	42	130	127	80	38	134	32
SM16-100	1615	42	HRC-150	2012	50	150	127	80	38	94	48
SM16-140	1615	42	HRC-150	2012	50	150	127	80	38	134	48
SM25-100	2517	65	HRC-180	2517	65	180	178	123	45	94	48
SM25-140	2517	65	HRC-180	2517	65	180	178	123	45	134	48
SM25-180	2517	65	HRC-180	2517	65	180	178	123	45	174	48
SM30-140	3020	75	HRC-230	3020	75	225	216	146	76	134	60
SM30-180	3020	75	HRC-230	3020	75	225	216	146	76	174	60
SM35-140	3525	100	HRC-280	3525	100	275	248	178	89	134	80
SM35-180	3525	100	HRC-280	3525	100	275	248	178	89	174	80

El acoplamiento HRC proporciona todas las características necesarias de un acoplamiento elástico ideal.

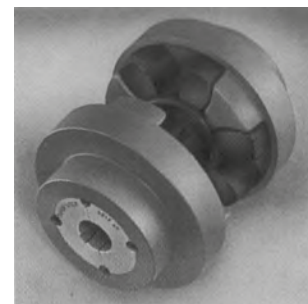

CARACTERÍSTICAS

- Fácil montaje
- Gran torsión elástica
- Trabaja a compresión
- Fijación con casquillo

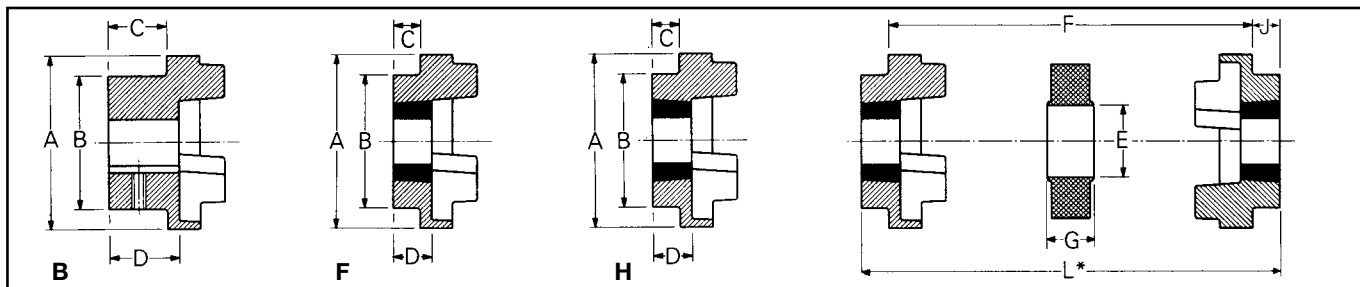

DIMENSIONES

Tipo	DIMENSIONES					TIPO F & H					TIPO B				
	A	B	E	F \pm	G	TAPER BUSH	AGUJER. MAX.(mm)	C	D	Jt	AGUJERO		TORNILLO	C	D
											Máx.	Min.			
70	69	60	31	25	18	1008	25	20,0	23,5	29	32	0	M 6	20	23,5
90	85	70	32	30,5	22,5	1108	28	19,5	23,5	29	42	0	M 6	26	30
110	112	100	45	45	29	1610	42	18,5	26,5	38	55	0	M10	37	45
130	130	105	50	53	36	1610	42	18,0	26,5	38	60	0	M10	39	47,5
150	150	115	62	60	40	2012	50	23,5	33,5	42	70	0	M10	46	56
180	180	125	77	73	49	2517	65	34,5	46,5	48	80	0	M10	58	70
230	225	155	99	85,5	59,5	3020	75	39,5	52,5	55	100	48	M12	77	90
280	275	206	119	105,5	74,5	3525	100	51,0	66,5	67	115	60	M16	90	105,5

CARACTERÍSTICAS

Tipo	L*=LONGITUD TOTAL			MASA (kg)	RIGIDEZ (Nm/°)	MÁXIMA DESALINEACIÓN		PAR (Nm) Nominal	
	FF, FH, HH	FB, HB	BB			Paralelo	Axial	NBR	Uretano
	70	65	65	65	1,00	-	0,3	+0,2	31
90	69,5	76	82,5	1,17	-	0,3	+0,5	80	240
110	82	100,5	119	5,00	65	0,3	+0,6	160	120
130	89	110	131	5,46	130	0,4	+0,8	315	472
150	107	129,5	152	7,11	175	0,4	+0,9	600	900
180	142	165,5	189	16,6	229	0,4	+1,1	950	1425
230	164,5	202	239,5	26,0	587	0,5	+1,3	2000	3000
280	207,5	246,5	285,5	50,0	1025	0,5	+1,7	3150	4725

VALOR DE POTENCIA (Kw)

Velocidad rev/min	TIPO DE ACOPLAMIENTO								
	70	90	110	130	150	180	230	280	
100	0,33	0,84	1,68	3,30	6,28	9,95	20,9	33,0	
400	1,32	3,35	6,70	13,2	25,1	39,8	83,8	132	
720	2,37	6,03	12,1	23,8	45,2	71,6	151	238	
800	2,64	6,70	13,4	26,4	50,3	79,6	169	264	
960	3,17	8,04	16,1	31,7	60,3	95,5	201	317	
1200	3,96	10,1	20,1	39,6	75,4	119	252	396	
1440	4,75	12,1	24,1	47,5	90,5	143	302	475	
1800	5,94	15,1	30,2	59,4	113	179	377	594	
2200	7,26	18,4	36,9	72,6	138	219	461	726	
2600	8,58	21,8	43,6	85,8	163	259	545	858	
2880	9,50	24,1	48,3	95	181	286			
3000	9,90	25,1	50,3	99	188	298			
3600	11,9	30,1	60,3	118	226				
Max Torque (Nm)	72	180	360	720	1500	2350	5000	7200	

El acoplamiento N-FLEX proporciona todas las características necesarias de un acoplamiento elástico ideal a la torsión.

Acabados

- Cubos ciegos
- Cubos taper
- Cubos mecanizados en stock



Acoplamiento apto para atmósferas explosivas
Certificado según la Directiva 94/9/CE

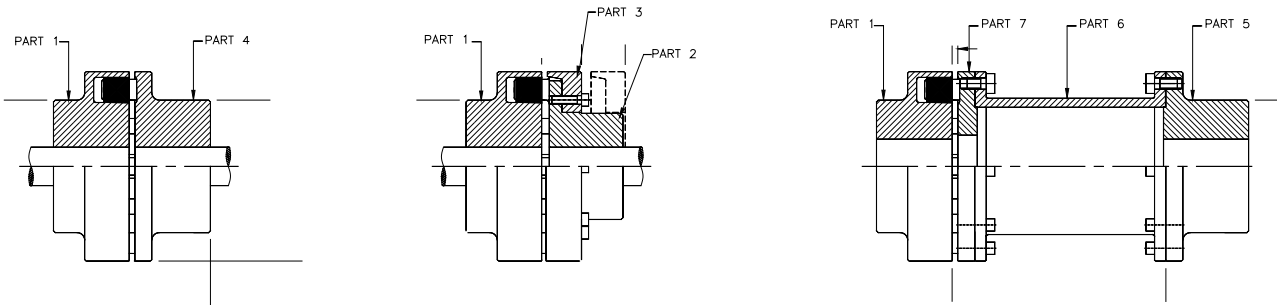

Programa de fabricación de cubos mecanizados:

Tipo	Parte	Eje mec.	Diámetro Agujero H7 + Chavetero																						
			19	20	22	24	25	28	30	32	35	38	40	42	45	48	50	55	60	65	70	75	80	85	90
95	1	•				•				•															
	4	•										•		•											
	5	•											•		•										
110	1	•				•				•				•											
	4	•														•									
	5	•														•									
125	1	•				•				•				•		•									
	4	•														•									
	5	•															•								
140	1	•								•				•											
	4	•																				•			
	5	•																				•	•		
160	1	•								•				•											
	4	•																					•		
	5	•																					•		
180	1	•								•				•											
	4	•																					•	•	

- Acabados con agujeros H7, chavetero standard y prisionero.
- Otros ejes disponibles bajo pedido.

PARTE 1



PARTE 4



PARTE 2+3



GOMAS



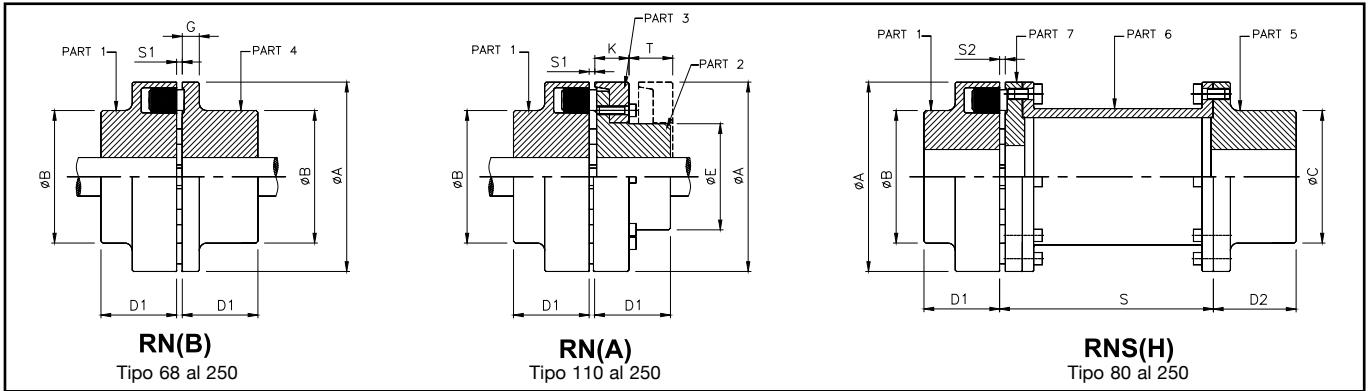

Dimensiones

Tipo RN	Par Nominal		Kw a 100 RPM	Máx. RPM	Agujero máx. Part (mm)				Dimensiones (mm)										Peso (kg)		
	NBR	URETANO			1	5	4	2	ØA	ØB	ØC	ØE	D1	D2	G	K	T	S	RN(B)	RN(A)	RNS(H)
68 B	34	51	0.36	5000	24	28	-	68	46	-	-	20	-	8	-	-	-	0.63	-	-	
80 B,H	60	90	0.63	5000	30	38	-	80	68	55	-	30	45	10	-	-	100 140	1.51	-	2.8 2.9	
95 B,H	100	150	1.1	5000	42	42	-	95	76	70	-	35	45	12	-	-	100 140	2.6	-	3.9 4.2	
A,B,H 110	160	240	1.7	5000	48	48	38	110	86	80	62	40	50	14	20	33	100 140 180	3.9	3.5	5.8 6.2 6.6	
A,B,H 125	240	360	2.5	5000	55	55	45	125	100	90	75	50	50	18	23	38	100 140 180	6.2	5.6	8.2 8.7 9.2	
A,B,H 140	360	540	3.8	4900	60	60	50	140	100	100	82	55	65	20	28	43	140 180 200	6.9	7	11.8 12.3	
A,B,H 160	560	840	5.9	4250	65	65	58	160	108	108	95	60	70	20	28	47	140 180 200	9.4	9.8	15.2 16.0	
A,B,H 180	880	1320	9.2	3800	75	75	65	180	125	125	108	70	80	20	30	50	140 180 200	14	14.2	21.0 21.9	
A,B,H 200	1340	2010	14	3400	85	85	75	200	140	140	122	80	90	24	32	53	180 200 250	20	19.8	30.3 30.9 32.1	
A,B,H 225	2000	3000	21	3000	90	90	85	225	150	150	138	90	100	18	38	61	180 200 250	24.5	27	39 39.7 41.5	
A,B,H 250	2800	4200	29	2750	100	100	95	250	165	165	155	100	110	18	42	69	200 250	34	37	54.7 56.5	

SERIE TAPER

Tipo	Par Nominal Máx.		R.P.M. Máx.	Taper N°	Agujero Máx. parte 1 y 4 d ₁	D ₁ parte 1 y 4		Peso parte 1 y 4	
	Nm	Nm				rev/min	kg	kg	
80	60	180	5000	1108	28	22.5	0.43	0.47	
95	100	300	5000	1210	32	26.5	0.60	0.65	
110	160	480	5000	1615	42	38.5	1.30	1.40	
125	240	720	5000	1615	42	32.5	1.52	1.80	
140	360	1080	4900	2012	50	32.5	1.70	2.10	
160	560	1680	4250	2517	65	46.0	2.60	3.00	
180	880	2640	3800	2517	65	46.0	3.27	3.20	
200	1340	4020	3400	3020	75	52.0	4.90	5.80	
225	2000	6000	3000	3020	75	52.0	5.65	6.50	
250	2800	8400	2750	3535	90	90.0	12.50	13.00	

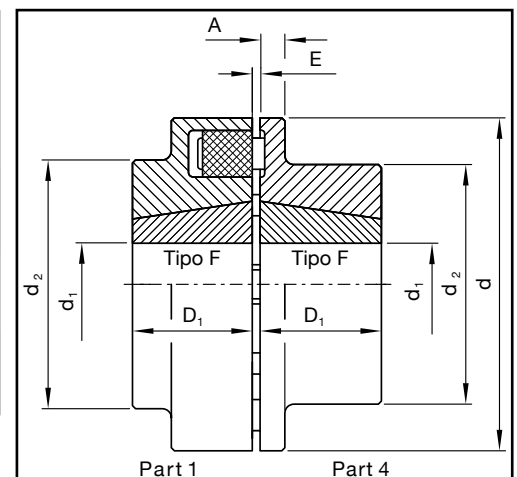

El acoplamiento RB se emplea en la construcción de maquinaria en general. Posee una gran elasticidad torsional.

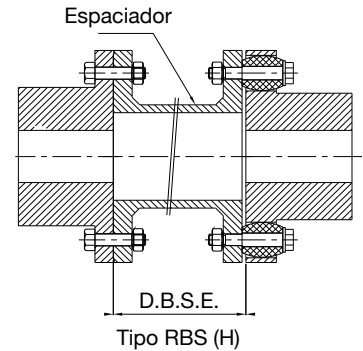
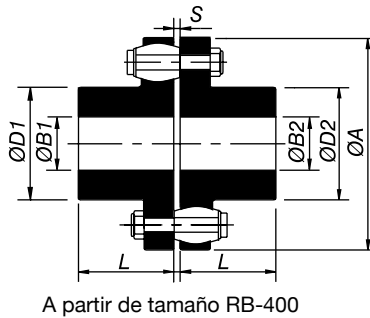
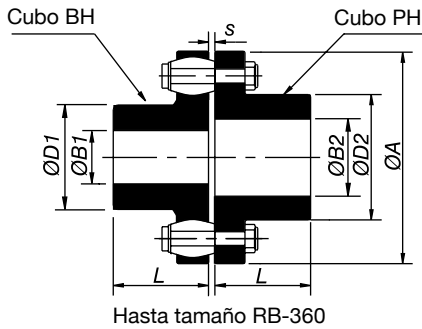

DIMENSIONES Y CARACTERÍSTICAS TÉCNICAS

Tipo	Par nominal (Nm)			Max rpm	Agujero min	Agujero Max.		ØA	ØD1	ØD2	L	S	Kg.	Desalineamiento Max.			DBSE
	NBR	Urethano	Hytrel			ØB1	ØB2							Axial m	Radial mm	Angular mm	
RB-105-3	96	143	230	7200	11	30	32	105	48	50	45	2-6	2,5	2	0,3	1°	100
RB-116-4	143	220	366	6100	12	39	42	116	60	68	45	2-6	3,6	2	0,3	1°	
RB-125-4	162	248	417	5500	14	45	50	125	68	78	50	2-6	4,8	2	0,4	1°	
RB-144-6	315	478	796	4900	18	50	60	144	82	91	55	2-6	4,3	2	0,4	1°	
RB-162-6	526	789	1314	4500	22	60	65	162	89	100	60	2-6	9,8	2	0,4	1°	
RB-178-6	640	965	1608	3800	24	70	75	178	105	115	70	2-6	13,5	2	0,5	1°	
RB-198-10	1242	1873	3121	3400	28	80	90	198	124	135	80	2-6	19,4	2	0,5	1°	140
RB-228-11	2007	3077	5128	3000	28	90	100	228	133	146	90	4-10	28	3	0,6	1°	
RB-252-12	3058	4606	7676	2700	38	105	115	252	156	167	100	4-10	38,5	3	0,6	1°	
RB-285-11	4586	6832	11386	2400	48	115	125	285	170	186	110	4-10	53,2	3	0,7	1°	180
RB-320-12	6115	9154	15256	2100	55	125	135	320	196	212	125	4-10	74,5	3	0,7	1°	
RB-360-11	8886	13358	22263	1900	65	135	150	360	212	232	140	4-12	106	4	0,9	1°	140-180
RB-400-10	12039	18084		1700	75	160	160	410	230	230	160	4-12	140	4	1,1	1°	CONSULTAR
RB-450-12	18632	27920		1500	85	180	180	450	260	260	180	4-12	160	4	1,1	0,5°	
RB-500-14	25799	38723		1350	95	200	200	500	290	290	200	4-12	250	4	1,1	0,4°	
RB-560-10	31054	46533		1200	95	225	225	560	320	320	220	4-8	380	2	1,5	0,3°	
RB-630-12	42042	63031		1050	100	250	250	630	355	355	240	4-8	365	2	1,5	0,3°	
RB-710-12	75007	112564		950	100	260	260	710	385	385	260	5-9	516	2	1,8	0,3°	
RB-800-14	100041	150090		850	100	280	280	800	420	420	290	5-9	691	2	1,8	0,3°	
RB-900-16	155078	232632		750	100	305	305	900	465	465	320	5-9	927	2	1,8	0,3°	
RB-1000-18	195113	292670		680	125	320	320	1000	515	515	350	5-10	1224	2	2	0,11	
RB-1120-18	270120			600	135	350	350	1120	560	560	380	6-11	1584	2	2,2	0,1°	
RB-1250-20	345222			550	150	380	380	1250	610	610	420	6-11	2070	2	2,4	0,1°	
RB-1400-20	530303			490	175	440	440	1400	700	700	480	6-12	3060	2	2,7	0,1°	
RB-1600-24	750450			430	200	480	480	1600	770	770	540	6-12	3960	2	3	0,1°	
RB-1800-22	975566			380	225	540	540	1800	870	870	600	8-16	5760	2	3,4	0,1°	
RB-2000-26	1300818			340	250	600	600	2000	960	960	650	8-16	7020	2	3,8	0,1°	

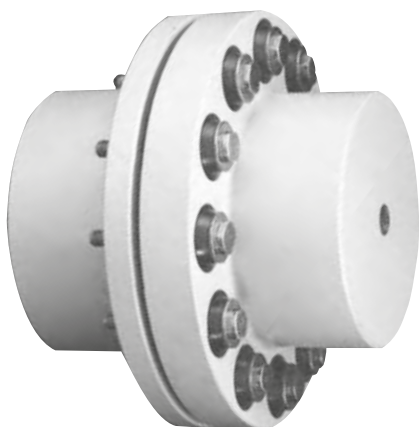

El acoplamiento LF actúa como amortiguador de sobrecargas y vibraciones.

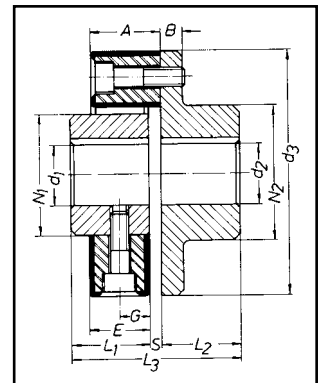
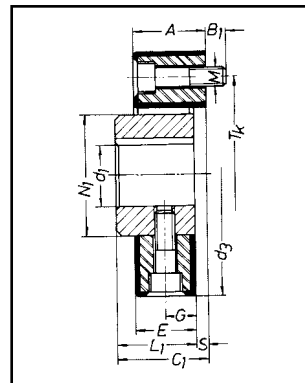
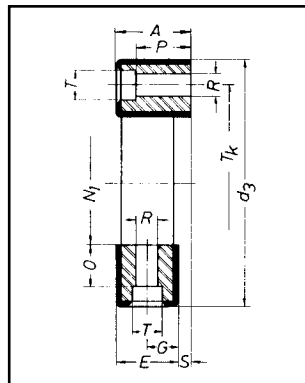

DIMENSIONES

Tipo	d1		d2		d3	A	B	B1	C1	E	G	L1	L2	L3	M	N1	N2	S	T
	mín.	máx.	mín.	máx.															
1	8	19	8	25	56	24	7	7	26	22	11	24	24	50	M6	30	36	2	10
2	10	28	12	38	85	24	8	8	32	20	10	28	28	60	M8	40	55	4	14
4	12	30	15	45	100	28	8	8	34	24	12	30	30	64	M8	45	65	4	14
8	12	38	18	55	120	32	10	10	46	28	14	42	42	88	M10	60	80	4	17
16	15	48	20	70	150	42	12	12	56	36	18	50	50	106	M12	70	100	6	19
22	15	48	20	70	150	42	12	12	56	36	18	50	50	106	M12	70	100	6	19
25	15	55	20	85	170	46	14	14	61	40	20	55	55	116	M14	85	115	6	22
28	15	55	20	85	170	46	14	14	61	40	20	55	55	116	M14	85	115	6	22
30	20	65	25	100	200	58	16	16	74	50	25	66	66	140	M16	100	140	8	25
50	20	65	25	100	200	58	16	16	74	50	25	66	66	140	M16	100	140	8	25
90	30	85	30	110	260	70	19	20	88	62	31	80	80	168	M20	125	160	8	32
140	30	85	30	110	260	70	19	20	88	62	31	80	80	168	M20	125	160	8	32
250	40	115	40	130	340	85	19	20	108	77	54,5	100	100	208	M20	160	195	8	32

Se dispone de tipos intermedios (consultar)

CARACTERÍSTICAS TÉCNICAS

Tipo			1	2	4	8	16	22	25	28	30	50	90	140	250
Descripción	Símbolo	Unidad													
1 Par Nominal	TKN	Nm	10	20	50	100	200	275	315	420	500	700	1100	1700	3000
2 Par Máximo	TKmáx	Nm	25	60	120	280	560	750	875	1200	1400	2100	3150	4900	8750
3 Ángulo de torsión	N máx.	grad. grad.	6 17	6 17	5 12	5 14	5 14	3 7,5	5 14	3 7,5	5 14	3 7,5	5 14	3 7,5	3 7,5
4 Velocidad máxima	n máx.	g/mín.	10000	8000	7000	6500	6000	6000	5000	5000	4000	4000	3600	3600	3000

FLEXIBILIDAD:

PARALELO 3 mm.

ANGULAR 4,5°

AXIAL 5 mm.

TORSIONAL 17°

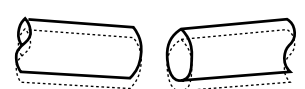
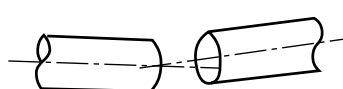
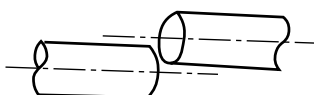

SECUENCIA DE MONTAJE:

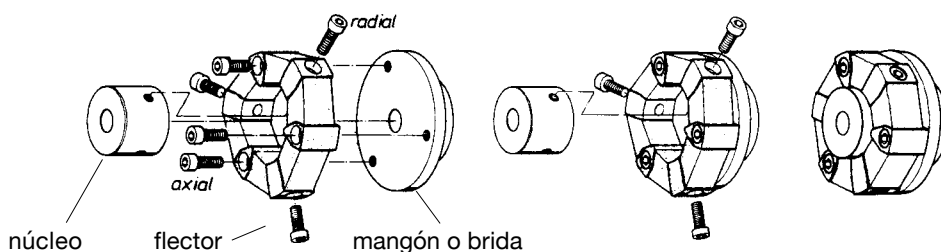

SERIE QUADRA-FLEX

El acoplamiento QUADRA-FLEX es adecuado en condiciones de trabajo con choques, vibraciones y desalineamientos.

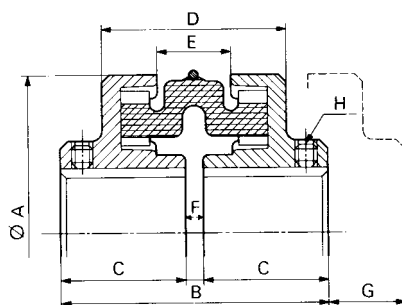

Tipo S

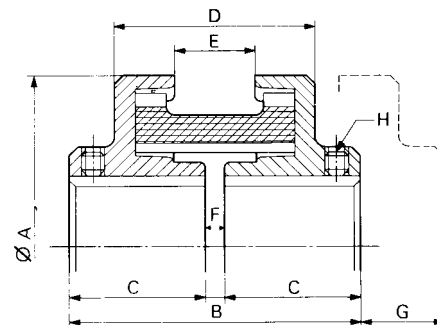

Tipo J

DIMENSIONES

Tipo	Agujero máx.	Dimensiones (mm)						Peso (kg)
		A	B	C	D	E+ΔE	H	
J3	22	52	53	20,5	32	12±1	M5	0,25
J4	25	62	62	22	39	18±1	M6	0,50
J5	32	83	76	27	48	22±1,5	M6	0,95

Tipo	Agujero		Dimensiones (mm)								Peso (kg)
	mín.	máx.	Ø A	B	C	D	E+ΔE	F	G	H	
S5	13	32	83	72	34	48	22±1,5	7	23	M6	0,95
S6	16	40	103	92	41	61	26±1,5	10	28	M8	2,30
S7	16	48	120	104	47	70	30±2	10	33	M8	3,40
S8	19	55	139	117	53	79	33±2	11	38	M10	5,30
S9	22	65	164	133	61	93	40±2	11	45	M10	8,10
S10	32	75	196	149	68	108	46±2,5	11	51	M12	13
S11	38	85	231	186	87	129	53±2,5	12	60	M16	22
S12	38	95	268	215	100	143	64±3	15	66	M16	34
S13	45	110	310	240	110	173	73±3	20	78	M16	50
S14	51	120	360	256	115	202	88±3	26	88	M16	71
S16	51	150	492	367	150	265	125±4	67	108	M20	165

TEMPERATURA: NEOPRENO: -18° + 93°C
 EPDM: -34° + 135°C
 HYTREL: -54° + 120°C

CARACTERÍSTICAS

Tipo	EPDM - NEOPRENO		HYTREL	
	Torque Nm	Máx. R.P.M.	Torque Nm	Máx. R.P.M.
3	7	9200	N/A	N/A
4	14	7600	N/A	N/A
5	27	7600	N/A	N/A
6	51	6000	203	6000
7	82	5250	325	5250
8	128	4500	512	4500
9	203	3750	813	3750
10	325	3600	1282	3600
11	512	3600	2034	3600
12	813	2800	3559	2800
13	1282	2400	5340	2400
14	2034	2200	8189	2200
16	5340	1500	N/A	N/A



JEM - JN



EM - E - N



JEMS - JNS



H - HS

CARACTERÍSTICAS

- Acoplamiento con cubierta de poliuretano ideal para ambientes agresivos
- Cubierta dividida en dos mitades, cada una unida a un soporte de metal

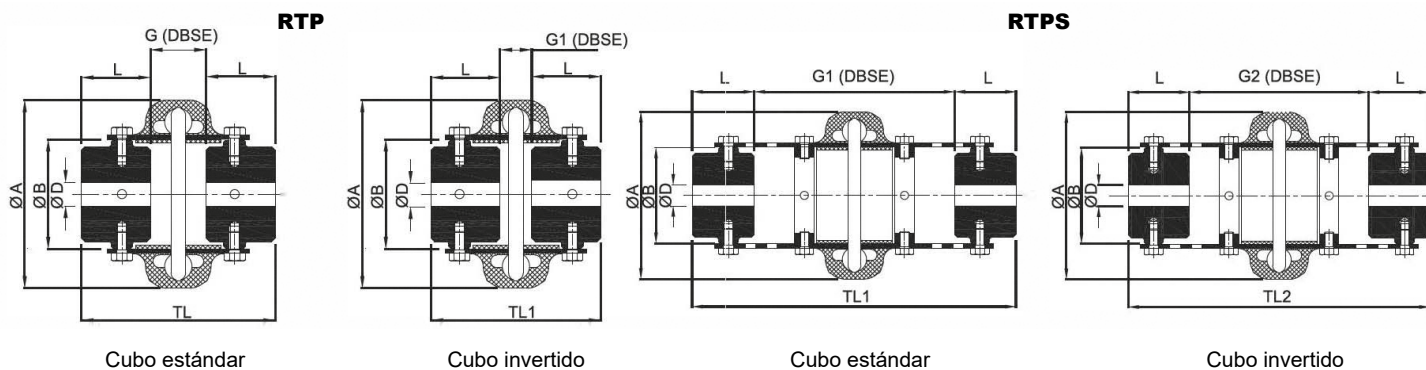

RTP Tipo	Potencia Kw (100rpm)	Par nominal Nm	Velocidad rpm (Max)	Agujero		Dimensiones							Peso kg
				ØD (Min)	ØD (Max)	ØA	ØB	L	DBSE		TL Largo total		
									Cubo estándar	Cubo invertido	Cubo estándar	Cubo invertido	
									G	G1	TL	TL1	
D2-RTP-90	0.23	22	7500	13	28	90	47	24	46	36	94	84	0.65
D3-RTP-103	0.45	43	7500	13	36	103	59	38	46	8	122	84	1
D4-RTP-117	0.66	63	7500	13	42	117	66	38	46	8	122	84	1.8
D5-RTP-138	1.15	110	7500	13	48	138	80	44	59	8	147	96	3
D10-RTP-163	1.89	181	7500	13	55	163	93	44	59	8	147	96	4.4
D20-RTP-185	2.72	260	6600	21	60	185	114	50	65	13	165	113	5.65
D30-RTP-211	4.34	414	5800	21	78	211	138	58	69	12	185	128	11.3
D40-RTP-245	6.58	628	5000	26	95	245	168	63	75	9	201	135	16.0
D50-RTP-283	9.16	875	4200	26	105	283	207	70	91	11	231	151	24.8
D60-RTP-319	14.99	1432	3800	31	115	319	222	82	97	8	261	172	35.1
D70-RTP-357	26.50	2531	3600	31	123	357	235	85	109	18	279	188	40.4

RTPS Tipo	Potencia Kw (100rpm)	Par nominal Nm	Velocidad rpm (Max)	Agujero		Dimensiones							Peso kg
				ØD (Min)	ØD (Max)	ØA	ØB	L	DBSE		TL Largo total		
									Cubo estándar	Cubo invertido	Cubo estándar	Cubo invertido	
									G1	G2	TL1	TL2	
D2-RTPS-90-R	0.23	0.22	7500	13	28	90	47	24	100	88	148	136	1
D3-RTPS-103-R	0.45	43	7500	13	36	103	59	38	100, 140	55, 95	176, 216	131, 171	1.3
D4-RTPS-117-R	0.66	63	7500	13	42	117	66	38	100, 140	55, 95	176, 216	131, 171	2.0
D5-RTPS-138-R	1.15	110	7500	13	48	138	80	44	100, 140	49, 89	188, 228	137, 177	3.5
D10-RTPS163-R	1.89	181	7500	13	55	163	93	44	100, 140	49, 89	188, 228	137, 177	4.8
D20-RTPS-185	2.72	260	6600	21	60	185	114	50	140, 180	85, 125	240, 280	185, 226	6.6
D30-RTPS-211	4.34	414	5800	21	78	211	138	58	100, 140	49, 89	188, 228	137, 177	11.3
D40-RTPS-245	6.58	628	5000	26	95	245	168	63	140, 180	71, 111	267, 307	198, 238	19.1
D50-RTPS-283	9.16	875	4200	26	105	283	207	70	140, 180	58, 98	280, 320	198, 238	28.2
D60-RTPS-319	14.99	1432	3800	31	115	319	222	82	180, 250	92, 162	344, 414	256, 326	36.3
D70-RTPS-357	26.50	2531	3600	31	123	357	235	85	180, 250	88, 159	350, 420	258, 329	41.6

SERIE LAMINAS REM



Los acoplamientos de láminas son ideales para aplicaciones en motores diésel y conducción en procesos industriales críticos, en aplicaciones marina y de generación de potencia.

Los acoplamientos de láminas cumplen la normativa para zonas con peligro de explosión.



ATEX/ISO-10441



A.P.I. 671/610

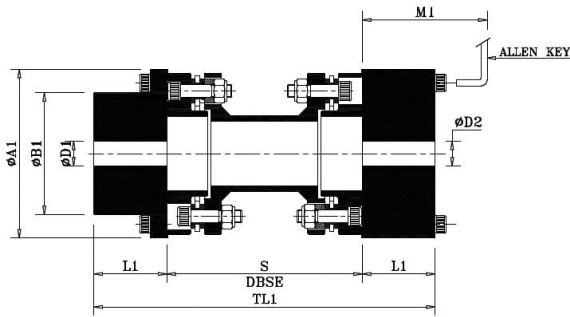

CUBO TIPO I

CUBO TIPO II

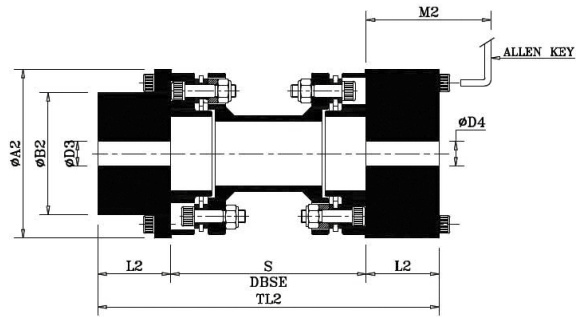

CUBO TIPO III

CUBO TIPO IV

CARACTERÍSTICAS REM

Tipo REM	Par Nom. Nm	Max. RPM	Agujero								Min. DBSE "S"	A1	A2	B1	B2	L1	L2	STD DBSE	T1 (STD DBSE)	T2 (STD DBSE)	M1	M2	Peso kg. aprox.		M.I. (MR2) en kg. m ² aprox		Tors. stiff. MNm/ rad aprox.			
			Min.		Max.				Min. DBSE "S"	Min. DBSE "S"													Per Mtr. Extra "S"	Min. DBSE "S"	Per Mtr. Extra "S"					
			D1 & D2 tipo I-II	D3 & D4 tipo I-II	D1 tipo I	D2 tipo II	D3 tipo III	D4 tipo IV																						
8	96	7500	8	10	24	42	38	48	80	69	90	40	55	30	40	100	160	180	80	90	2	1.32	0.0012	0.0002	0.018					
																										200	220	240	260	
																										180	190	220	230	260
25	232	7000	10	15	38	48	48	72	89	90	108	55	70	40	45	140	180	190	230	90	105	4	2.29	0.0039	0.0006	0.043				
																											270	290	340	360
																											250	260	290	300
65	618	6000	15	20	48	72	65	92	103	108	135	70	86	45	55	140	180	230	250	105	120	9	3.19	0.0094	0.0011	0.100				
																											270	290	340	360
																											180	250	290	300
125	1204	5200	20	25	65	92	80	102	128	135	152	86	108	55	60	180	250	250	260	120	125	16	4.74	0.0283	0.0034	0.232				
																											290	300	360	370
																											180	300	360	370
165	1912	4800	25	30	80	102	90	120	148	152	182	108	130	60	70	180	250	300	320	125	135	22	8.38	0.0604	0.0088	0.395				
																											370	390	430	440
																											180	320	360	430
370	3463	4400	30	45	90	120	108	140	161	182	197	130	158	70	90	180	250	320	360	135	155	33	13.08	0.1410	0.0213	0.749				
																											390	430	440	440
																											180	360	370	440
390	5583	4200	45	55	108	140	127	155	175	197	225	158	181	90	95	180	250	370	370	155	160	49	21.72	0.3650	0.0561	1.649				
																											430	440	440	440
																											180	370	390	440
790	7084	4000	55	65	127	155	140	178	180	225	250	181	206	95	105	180	250	370	390	160	170	61	21.72	0.4181	0.0561	1.649				
																											440	460	460	460
																											180	370	390	460
1025	10383	3800	65	70	140	178	155	192	194	250	275	206	223	105	115	180	250	460	480	170	190	83	27.06	0.7067	0.0670	2.179				
																											480	510	510	510
																											180	460	480	510
1425	14536	3700	70	75	155	192	170	212	213	275	300	223	248	115	130	180	250	480	510	190	215	105	42.79	1.1340	0.1666	3.350				
																											510	510	510	510
																											180	480	510	510
1880	18714	3600	75	80	170	212	190	255	225	300	375	248	280	130	145	180	250	510	540	215	245	136	42.79	1.7740	0.1666	4.271				
																											510	540	540	540
																											180	510	540	540

- 1.- Especificar tipos de cubo. Posibles combinaciones en tipos de cubo son: I/I, I/II, II/II, III/III, III/IV, IV/IV. 2.- Peso, M.I. y Rigidez indicados, son con agujeros máximos y min DBSE con combinación de cubos I/II. 3.- Los agujeros mínimos especificados son para los cubos tipo I/II, para los cubos III/IV consultar.
- 4.- Datos M1 aplicables para el cubo tipo II. Datos M2 aplicables para el cubo tipo IV.
- 5.- Disponible, bajo pedido, para aplicaciones API-ATEX.
- 6.- Espaciador no standard disponible bajo pedido.
- 7.- Acoplamientos superiores al 1880, disponibles bajo pedido.

TIPO RLM

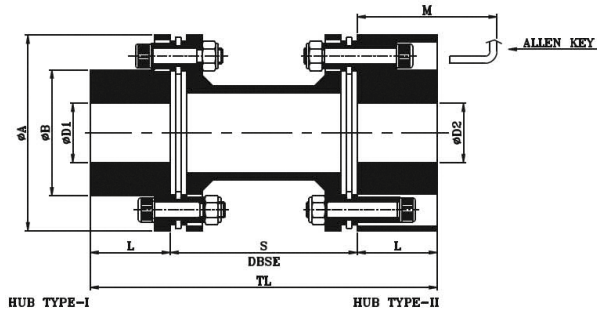

CUBO TIPO I

CUBO TIPO II

TIPO RLMK

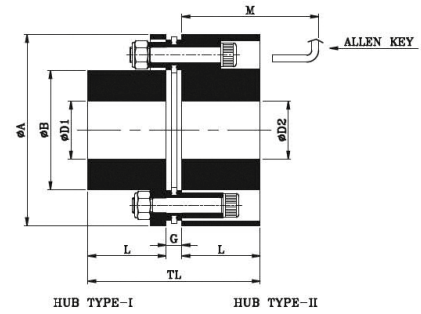

CUBO TIPO I

CUBO TIPO II

CARACTERÍSTICAS RLM

Tipo RLM	Par Nom. Nm	Max. RPM	Agujero			Min. DBSE "S"	ØA	ØB	L	STD DBSE "S"	TL (STD DBSE)	M	Peso kg. aprox.		M.I. (MR2) en kg. m ² aprox		Tors. stiff. MNm/rad aprox.
			Min. ØD1 & ØD2	Max.									Min. DBSE "S"	Per Mtr. Extra "S"	Min. DBSE "S"	Per Mtr. Extra "S"	
				ØD1 (tipo I)	ØD2 (tipo II)												
10	96	7500	10	22	25	54	63	30	100 140	160, 200	75	1.3	2.3	0.0006	0.0004	0.021	
35	232	7000	12	30	38	54	82	40	100 140 180	180, 220, 260	85	2.3	3.2	0.0021	0.0011	0.047	
95	618	6000	17	40	50	66	102	45		190, 230, 270	95	4.7	6.0	0.0062	0.0017	0.100	
170	1204	5200	17	52	70	78	128	55		210, 250, 290	110	8.0	7.0	0.0180	0.0047	0.222	
220	1912	4800	22	65	80	88	146	60		220, 260, 300	120	11.4	8.4	0.0350	0.0088	0.381	
400	3463	4400	27	80	100	102	176	115	140 180	280, 320	140	19.5	13.1	0.0850	0.021	0.773	
520	5583	4200	32	90	115	114	197	132	140 180	320, 360, 430	175	29.3	21.7	0.1678	0.056	0.962	
1000	7084	4000	42	105	130	132	225	147	180 250	330, 370, 440	185	42.1	21.1	0.3098	0.056	1.529	
1300	10383	3800	47	115	140	144	250	162	180 250 300	390, 460, 510	195	61.0	27.1	0.5328	0.067	1.892	
2000	14536	3700	52	120	155	168	275	178		410, 480, 530	215	81.7	42.8	0.8610	0.167	2.454	
2500	18714	3600	62	135	165	170	300	190		440, 510, 560	235	106.9	42.8	1.3580	0.167	3.783	

CARACTERÍSTICAS RLMK

Tipo RLMK	Par Nom. Nm	Max. RPM	Agujero			ØA	ØB	L	DBSE "G"	TL (STD DBSE)	M	Peso kg. aprox.	M.I. (MR2) en kg. m ² aprox	Tors. stiff. MNm/rad aprox.	Máxima desalineación		
			Min. ØD1 & ØD2	Max.											Axial	Angular	
				ØD1 (tipo I)	ØD2 (tipo II)												(mm)
10	96	7500	10	22	25	63	35	30	6.5	66.5	75	0.9	0.00047	0.041	±1	0.75°	
35	232	7000	12	30	38	82	45	40	6.5	86.5	85	1.8	0.0017	0.093			
95	618	6000	17	40	50	102	57	45	8	98	95	3.2	0.0082	0.248			
170	1204	5200	17	52	70	128	77	55	9.5	119.5	110	5.8	0.0143	0.248			
220	1912	4800	22	65	80	146	94	60	12	132	120	8.5	0.0263	0.529			
400	3463	4400	27	80	100	176	115	70	13	153	140	14.0	0.0640	0.895			
520	5583	4200	32	90	115	197	132	90	14.4	194.5	175	22.2	0.1320	1.665			
1000	7084	4000	42	105	130	225	147	95	16.2	206.1	185	30.5	0.2311	2.393			
1300	10383	3800	47	115	140	250	162	105	19.5	229.4	195	42.7	0.3945	3.490			
2000	14536	3700	52	132	155	275	178	115	21.5	251.5	215	57.3	0.6350	CONSULTAR			
2500	18714	3600	62	147	165	300	190	130	23.5	283.6	235	76.1	1.0050				

ACOPLAMIENTOS DE MUELLES HORIZONTALES

Acoplamientos con cubiertas de apertura horizontal ideales para aplicaciones con espacio limitado. Esta cubierta permite un fácil acceso al muelle y es muy apropiado para aplicaciones con variaciones en el sentido de la marcha.

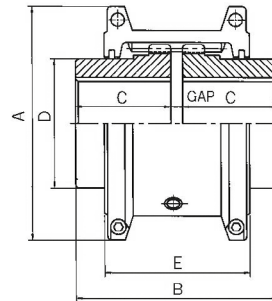
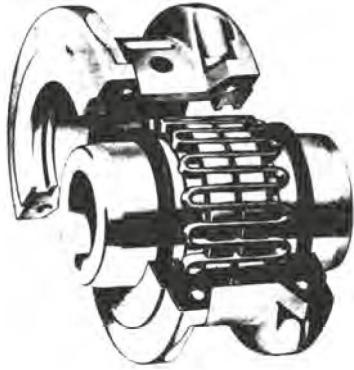

ACOPLAMIENTOS DE MUELLES VERTICALES

Acoplamientos con cubiertas de apertura vertical ideales para aplicaciones con velocidades operativas más altas.

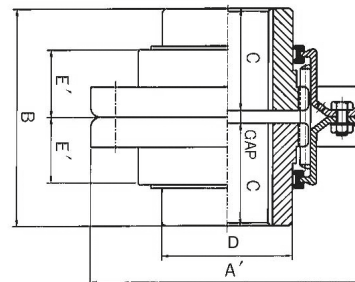

Tipo	Par Nominal Nm	Vel. Máx. (rpm)	Eje (mm)		Dimensiones (mm)								GAP (Hueco mm)			Peso (kg)	Lubric. wt(kg)
			Max.	Min.	A	A'	B	C	D	E	E'	Min.	Normal	Max.			
1020	48	4.500	30	12.7	101.6	111.1	98.0	47.5	39.7	66.5	24.2	1.5	3	4.5	1.9	0.03	
1030	138	4.500	36	12.7	111.0	120.7	98.0	47.5	49.2	68.3	25.0	1.5	3	4.5	2.6	0.03	
1040	230	4.500	44	12.7	117.5	128.5	104.6	50.8	57.1	70.0	25.7	1.5	3	4.5	3.4	0.05	
1050	403	4.500	50	12.7	138.0	147.6	123.6	60.3	66.7	79.5	31.2	1.5	3	4.5	5.4	0.05	
1060	633	4.350	57	19.1	150.5	162.0	130.0	63.5	76.2	92.0	32.2	1.5	3	4.5	7.3	0.09	
1070	921	4.125	68	19.1	161.9	173.0	155.4	76.2	87.3	95.0	33.7	1.5	3	4.5	10	0.11	
1080	1901	3.600	82	27.0	194.0	200.0	180.8	88.9	104.8	116.0	44.2	1.5	3	6	18	0.17	
1090	3456	3.600	95	27.0	213.0	232.8	199.8	98.4	123.8	122.0	47.7	1.5	3	6	25	0.25	
1100	5818	2.440	107	41.3	250.0	266.7	245.7	120.6	142.0	155.5	60.0	1.5	4.5	9.5	42	0.43	
1110	8641	2.250	117	41.3	270.0	285.8	258.5	127.0	160.3	161.5	64.2	1.5	4.5	9.5	54	0.51	
1120	12673	2.025	136	60.3	308.0	319.0	304.4	149.2	179.4	191.5	73.4	1.5	6	12.5	81	0.73	
1130	18434	1.800	165	66.7	346.0	377.8	329.8	161.9	217.5	195.0	75.1	1.5	6	12.5	121	0.91	
1140	26599	1.650	184	66.7	384.0	416.0	371.6	182.8	254.0	201.0	78.2	1.5	6	12.5	178	1.13	

Otras medidas consultar.

SERIE GEAR METÁLICO



Los acoplamientos flexibles de dientes abombados presentan estas ventajas: Robustos, totalmente contruidos en acero, no llevan elementos elásticos susceptibles de desgaste, permiten con pequeñas dimensiones transmitir fuertes potencias y grandes velocidades de rotación.

Son utilizados en la actualidad en las más diversas ramas de la industria, donde confirman su superioridad al cumplir con las exigencias deseadas de:

- Potencias: Servicios continuos y fuertes en minas, siderurgia, petroleros y demás navíos de gran tonelaje, etc.
- Velocidades: Bombas de alimentación de centrales térmicas, compresores centrífugos y turbinas, bancos de ensayo de aviación, etc.
- Seguridad: Grúas puente de siderurgia, montacargas o ascensores de minas y portaviones, material rodante de transporte, etc.

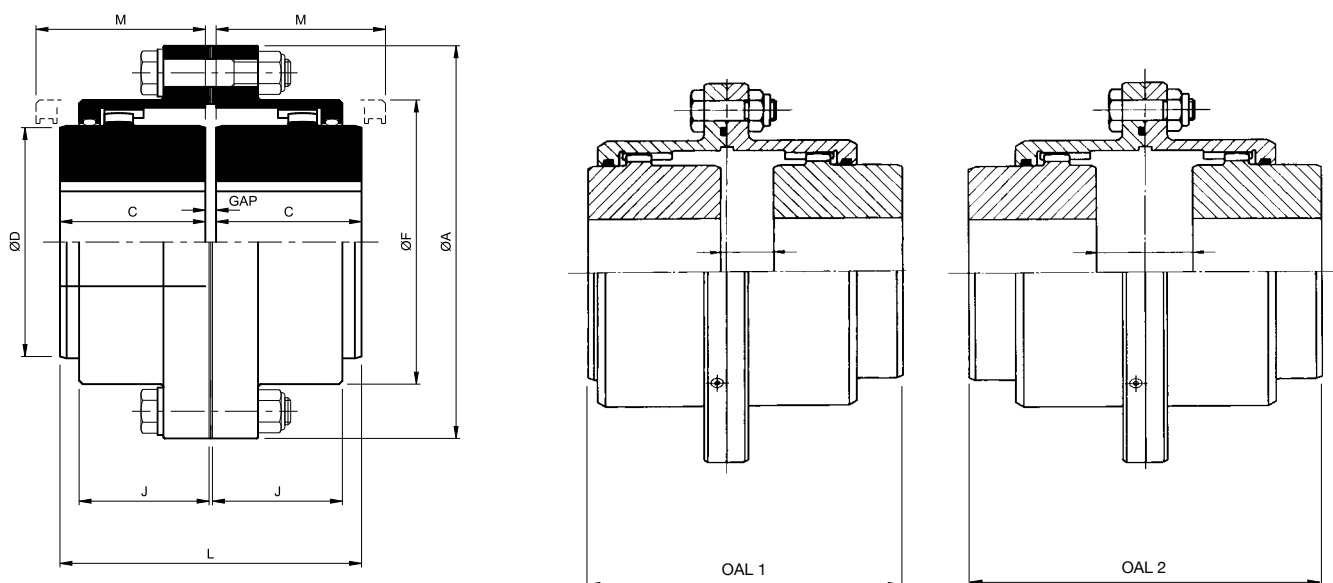

Tipo	Par nominal Nm	Velocidad máxima r.p.m.	Ø Agujero mm		Dimensiones (mm)									Peso Kg	MR ² intertia kg m ²	
			mín.	máx.	Ø A	L	C	Ø D	Ø F	J	M	OAL1	OAL2			Gap
1-10	1.400	8000	14	52	116	89	43	69	84	39	51	97	105	3	4.4	0.0052
1,5-15	3.000	6500	22	65	152	103	50	86	105	48	61	108	114	3	9	0.0192
2-20	5.300	5600	27	80	178	127	62	105	127	60	76	148	162	3	15	0.041
2,5-25	10.500	5000	32	98	213	159	77	131	155	72	92	179	198	5	27	0.105
3-30	16.800	4400	42	115	240	187	91	152	181	84	106	204	221	5	40	0.195
3,5-35	23.100	3900	47	135	279	220	107	178	211	98	130	233	248	6	65	0.454
4-40	33.600	3600	47	160	318	248	121	210	250	111	145	265	283	6	96	0.86
4,5-45	47.200	3200	52	180	346	278	135	235	274	123	165	305	332	8	131	1.39
5-50	65.000	2900	72	195	389	314	153	254	306	141	183	348	383	8	186	2.53
5,5-55	88.000	2650	72	215	425	344	168	279	334	158	203	390	421	8	247	3.83
6-60	120.500	2450	77	235	457	384	188	305	366	169	228	420	456	8	299	5.21
7-70	182.300	2150	92	280	527	451	221	356	425	196	266	484	518	9	473	11

SERIE DE CADENA / PIÑÓN

Acoplamiento compacto y de excelente durabilidad, fácil montaje y desmontaje. Los acoplamientos de cadena se pueden suministrar con tres tipos de acabado: Ciegos, Mecanizados ambos lados y Taper con dientes tratados.

CARACTERÍSTICAS:

- Temperatura trabajo: -35°C , +120°C.
- Desalineamiento angular 2% máximo permitido.
- Desalineamiento paralelo 0,038% máximo permitido según paso cadena.

DIMENSIONES (ACOPLAMIENTOS CIEGOS Y MECANIZADOS)

Tipo Ref.	A	B	C	L	OD	Agujero Max.	RPM Max.
AC08B12	33	28	7	63	61	22	5000
AC08B16	50	28	7	63	77	32	5000
AC10B16	60	30	9	69	96	42	4000
AC10B18	70	30	9	69	106	45	3600
AC12B18	80	35	11	81	127	56	3000
AC12B20	80	35	11	81	139	60	2500
AC12B22	90	40	11	91	151	70	2500
AC16B18	100	45	14	104	169	80	2000
AC16B20	100	45	14	104	185	80	2000
AC20B20	120	50	18	118	231	100	1800
AC24B18	140	60	21	141	254	120	1500
AC24B22	140	60	21	141	302	120	1200

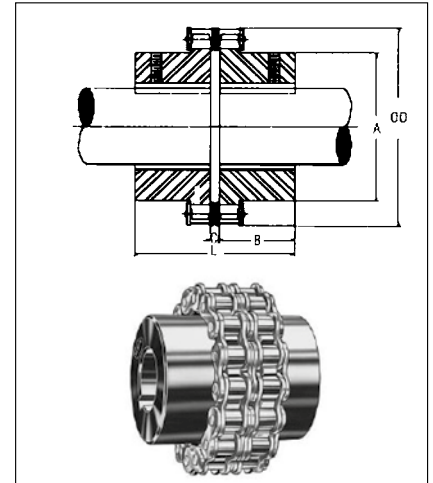

DIMENSIONES (ACOPLAMIENTOS TAPER CON DIENTES TRATADOS)

Tipo Ref.	A	B	C	L	OD	Taper	Agujero Max.
AC08B16	52	22	7	63	77	1108	28
AC10B16	71	25	9	69	96	1610	42
AC10B18	75	25	9	69	106	1610	42
AC12B18	90	32	11	81	127	2012	50
AC12B20	95	32	11	81	139	2012	50
AC12B22	102	44	11	91	151	2517	60
AC16B18	108	44	14	104	169	2517	60
AC16B20	108	44	14	104	185	2517	60
AC20B20	108	44	18	118	231	2517	60
AC24B18	133	50	21	141	254	3020	75
AC24B22	133	50	21	141	302	3020	75



VALORES DE POTENCIA (máxima en Kw)

Tipo Referencia	rpm													PAR MAX (Nm) permitido por debajo de 50 rpm
	50	100	200	300	400	500	600	800	1000	1200	1500	1800	2000	
AC08B12	1,15	1,73	2,63	3,46	4,15	4,96	5,67	7,01	8,53	9,68	11,6	13,7	14,8	200
AC08B16	2,06	3,09	4,69	6,17	7,41	8,85	10,1	12,5	15,3	17,3	21	24,4	26,3	350
AC10B16	3,91	5,86	8,92	11,7	14,1	16,8	19,2	23,8	28,9	32,9	39,9	46,4	50	700
AC10B18	4,95	7,43	11,3	14,9	17,8	21,3	24,4	30,1	36,6	41,6	50,5	58,8		900
AC12B18	9,33	14	21,3	28	33,6	40,1	45,9	56,8	69,1	78,4	95,2	111		1.700
AC12B20	10,9	16,4	24,9	32,8	39,4	47,1	51	64,1	81,1	91,7	112			2.000
AC12B22	12,5	18,8	28,6	37,7	45,3	54,1	61,9	76,5	93,1	105	128			2.300
AC16B18	20,7	31	47,2	62,1	74,5	89	101	126	153	174	211			3.500
AC16B20	25,1	37,7	57,2	75,5	90,2	108	123							4.500
AC20B20	46,6	70	106	140	168	200	229	283	345					8.000
AC24B18	70,2	105	160	210	252	302	345	426						12.000
AC24B22	90,7	136	206	272	326	390	446							15.000
	A		B		C									

NOTA: Mantenimiento recomendado de lubricación: A mensual - B semanal - C constante.

SERIE RÍGIDO RM

Ofrecen un método de conexión rígido de ejes. El montaje es con bujes taper, que permiten fijarse más fácil y rápidamente a los ejes con la firmeza de un ajuste por contracción.

Para conectar ejes verticales, usar sólo ensamblaje FF.

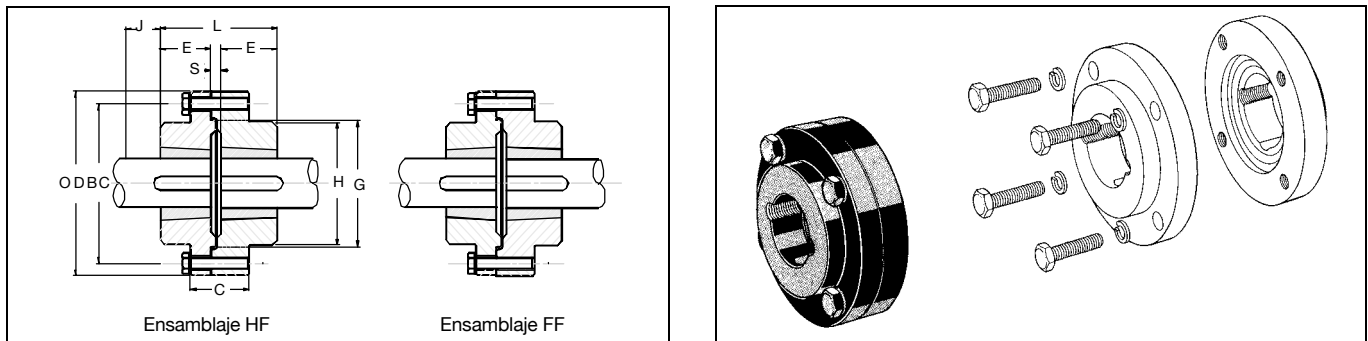

Dimensiones

Tipo	Taper	Agujero Máx.	OD	C	H	E	G	BC	S+	J	L	Peso++ (kg)
RM12	1210	32	118	35	83	25	76	102	7	38	57	3,5
RM16	1615	42	127	43	80	38	89	105	7	38	83	4,5
RM25	2517	65	178	51	123	45	127	149	7	48	97	11
RM30	3020	75	216	65	146	51	152	181	7	54	109	20
RM35	3525	100	248	75	178	65	178	213	7	67	137	34
RM40	4030	110	298	76	210	76	216	257	7	79	159	59
RM45	4535	125	330	86	230	89	241	286	7	89	185	80
RM50	5040	125	362	92	266	102	267	314	7	92	211	135

SERIE MRC

El acoplamiento MRC está formado por dos cubos de acero unidos por una corona de resina sintética.

- Temperatura de funcionamiento: entre -25°C y 100°C.
- Dientes curvos y rectificadas.

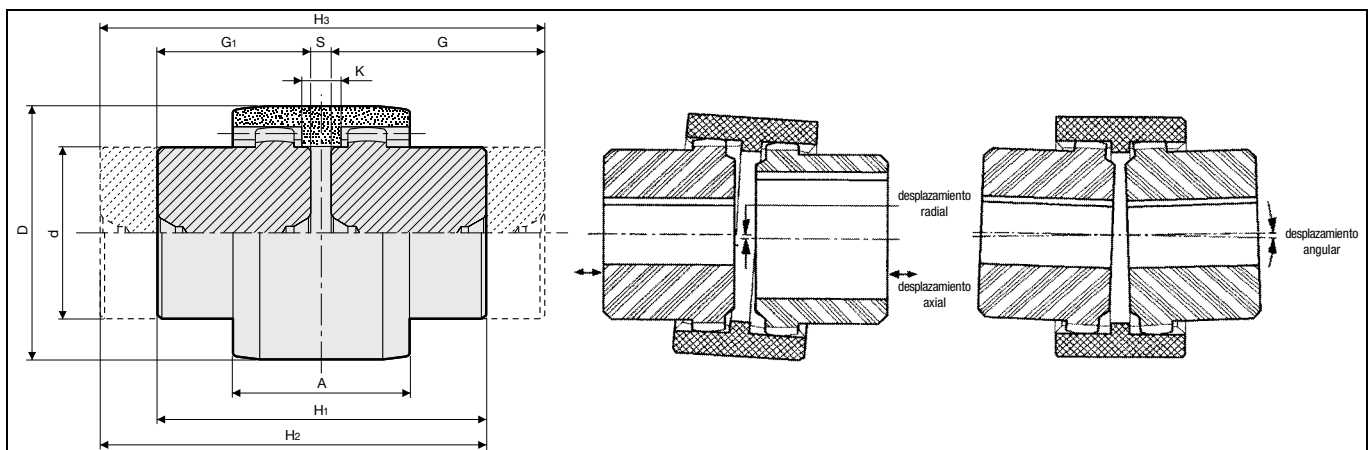

Dimensiones

Tipo MRC	Eje		Dimensiones (mm)										Par		Máx. RPM	Tolerancias desalineamientos			Peso apróx. (kg)
	Mín.	Máx.	A	d	G	G ₁	D	S	K	H ₁	H ₂	H ₃	Nominal	Máx.		Axial	Paralelo	Angular	
14	6	14	37	24	40	23	40	4	6	50	67	84	10	20	14000	+/- 1	+/- 0,3	+/- 1	0,19
19	8	19	37	30	40	25	48	4	6	54	69	84	16	32	11800				0,23
24	10	24	41	36	50	26	52	4	8	56	80	104	20	40	10600				0,32
28	10	28	46	44	55	40	66	4	9	84	99	114	45	90	8500				0,73
32	12	32	48	50	55	40	76	4	9	84	99	114	60	120	7500				0,96
38	14	38	48	58	60	40	83	4	9	84	104	124	80	160	6700				1,23
42	20	42	50	65	60	42	92	4	9	88	106	124	100	200	6000				1,50
48	20	48	50	67	60	50	95	4	9	104	114	124	140	280	5600				1,82
55	25	55	58	82	66	52	114	4	10	108	121	134	270	540	4800				4,20
65	25	65	68	95	70	55	132	4	12	114	129	144	380	760	4000				5,20

SERIE CARDAN



Las juntas Cardan se emplean en aplicaciones en las que la transmisión puede ser larga e incluso variable durante el funcionamiento y admiten desalineaciones elevadas.



Tipo	Par Nominal (N-m)	Eje máximo cubo (mm)		Ángulo máx.	Longitud Larga RDT (mm)		Longitud corta RDS (mm)	
		RDH	RDJ		Comprimida	Extendida	Comprimida	Extendida
1130 ●	550	32	50	17°	315	358	208	232
1310 ■	1085	40	58	25°	335	385	250	275
1410 ■	2034	48	68	20°	471	529	250	280
1480 ■	2712	65	92	20°	418	481	270	320
1550 ■	3255	65	92	20°	445	508	308	341
1610 ●	4950	80	115	20°	500	570	377	422
1710 ●	6511	90	135	20°	638	771	485	583
1720 ●	6511	66	100	15°	650	783	480	578

Plato SAE
6 1/2"
7 1/2"
8"
10"
11 1/2"
14"

- Brida redonda
- Brida rectangular

Cardan super corta disponible
Tamaños más grandes bajo pedido

LÁMINAS CALIBRADAS



Las Láminas Calibradas de una sola ranura de RATHI juegan un papel crucial en el posicionamiento ajustado del equipo así como una perfecta alineación de los ejes.

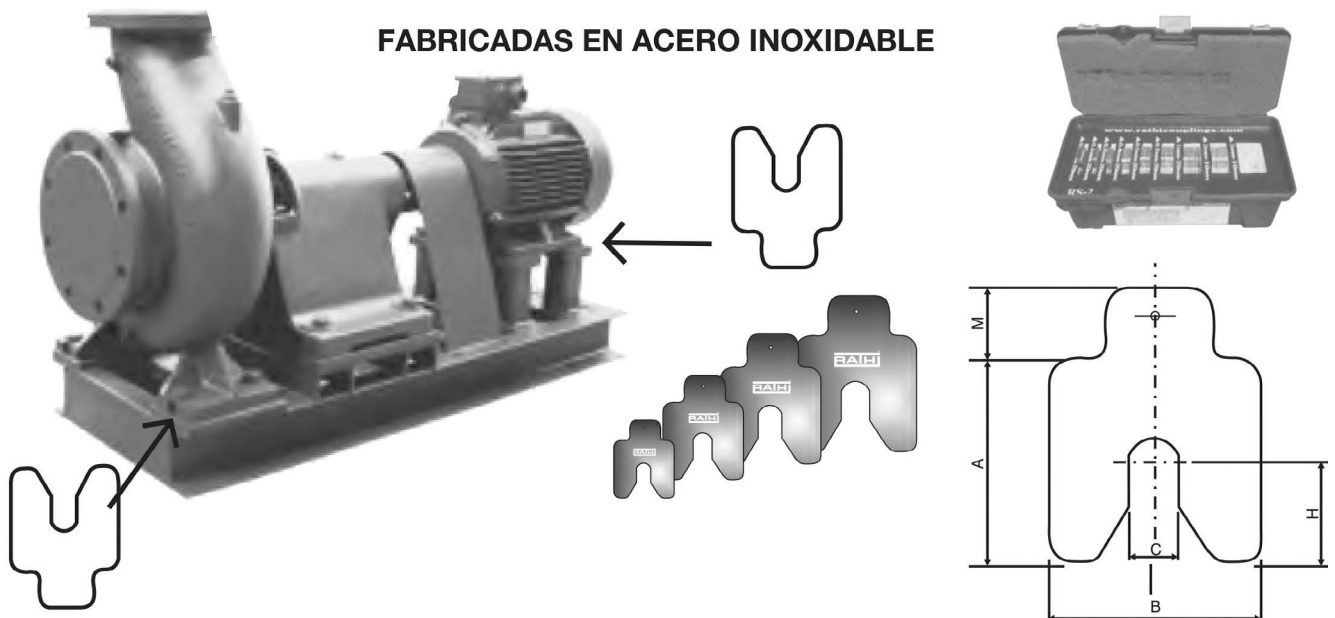

FABRICADAS EN ACERO INOXIDABLE

DIMENSIONES

Tipo	A	X	B	C	H	M	REFERENCIA MOTOR	GROSOR
RS 1	40	X	40	13	20	16	56 - 63 - 71	0.05, 0.10
RS 2	50	X	50	17	25	18	80 - 90 - 100 - 112 - 132	0.20, 0.40
RS 3	75	X	75	21	37.5	18	160 - 180	0.50, 0.70
RS 4	100	X	100	27	50	25	200 - 225 - 250 - 280	1.0, 2.0
RS 5	125	X	125	45	62.5	30	315 - 355 - 400	3.0
RS 6	200	X	200	55	100	30	450	

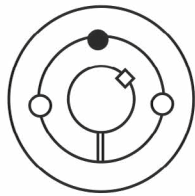

1008 hasta
3030

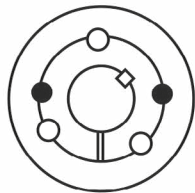

3535 hasta
6050

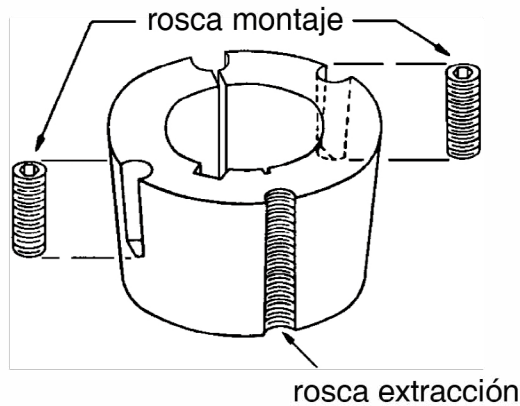

7060 hasta
10085

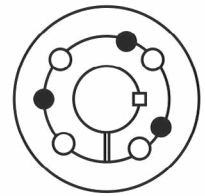

120100

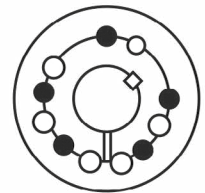

SUMINISTRO CASQUILLOS TAPER METRICO

REF.	DIAMETRO DE EJES NORMALIZADOS CON RANURA PARA CHAVETA-DIN 6885/VSM 15161
1008	09 - 10 - 11 - 12 - 14 - 16 - 18 - 19 - 20 - 22 - 24 - 25
1108	09 - 10 - 11 - 12 - 14 - 16 - 18 - 19 - 20 - 22 - 24 - 25 - 28
1210	11 - 12 - 14 - 16 - 18 - 19 - 20 - 22 - 24 - 25 - 28 - 30 - 32
1215	22 - 24 - 28 - 30
1610	14 - 15 - 16 - 18 - 19 - 20 - 22 - 24 - 25 - 28 - 30 - 32 - 35 - 38 - 40 - 42
1615	14 - 15 - 16 - 18 - 19 - 20 - 22 - 24 - 25 - 28 - 30 - 32 - 35 - 38 - 40 - 42
2012	14 - 16 - 18 - 19 - 20 - 22 - 24 - 25 - 28 - 30 - 32 - 35 - 38 - 40 - 42 - 45 - 48 - 50
2517	16 - 18 - 19 - 20 - 22 - 24 - 25 - 28 - 30 - 32 - 35 - 38 - 40 - 42 - 45 - 48 - 50 - 55 - 60 - 65
3020	25 - 28 - 30 - 32 - 35 - 38 - 40 - 42 - 45 - 48 - 50 - 55 - 60 - 65 - 70 - 75
3030	35 - 38 - 40 - 42 - 45 - 48 - 50 - 55 - 60 - 65 - 70 - 75
3525	35 - 38 - 40 - 42 - 45 - 48 - 50 - 55 - 60 - 65 - 70 - 75 - 80 - 85 - 90 - 95 - 100
3535	35 - 38 - 40 - 42 - 45 - 48 - 50 - 55 - 60 - 65 - 70 - 75 - 80 - 85 - 90
4030	40 - 42 - 45 - 48 - 50 - 55 - 60 - 65 - 70 - 75 - 80 - 85 - 90 - 95 - 100 - 105 - 110
4040	35 - 40 - 42 - 45 - 48 - 50 - 55 - 60 - 65 - 70 - 75 - 80 - 85 - 90 - 95 - 100
4535	55 - 60 - 65 - 70 - 75 - 80 - 85 - 90 - 95 - 100 - 105 - 110 - 115 - 120 - 125
4545	55 - 60 - 65 - 70 - 75 - 80 - 85 - 90 - 95 - 100 - 105 - 110 - 115 - 120
5050	70 - 75 - 80 - 85 - 90 - 95 - 100 - 105 - 110 - 115 - 120 - 125

NORMA DE CHAVETERO		
Diámetro	Ancho mm	Profun. mm
de 9 a 10	3	1,4
de 11 a 12	4	1,8
de 14 a 16	5	2,3
de 18 a 22	6	2,8
de 24 a 30	8	3,3
de 32 a 38	10	3,3
de 40 a 42	12	3,3
de 45 a 50	14	3,8
55	16	4,3
de 60 a 65	18	4,4
de 70 a 75	20	4,9
de 80 a 85	22	5,4
de 90 a 95	25	5,4
de 100 a 110	28	6,4
de 115 a 125	32	7,4

SUMINISTRO CASQUILLOS TAPER PULGADAS

REF.	DIAMETRO DE EJES NORMALIZADOS CON RANURA PARA CHAVETA
1008	3/8 - 1/2 - 5/8 - 3/4 - 13/16 - 7/8 - 15/16 - 1
1108	3/8 - 7/16 - 1/2 - 9/16 - 5/8 - 11/16 - 3/4 - 13/16 - 7/8 - 1 - 1.1/16 - 1.1/8
1210	1/2 - 5/8 - 11/16 - 3/4 - 13/16 - 7/8 - 15/16 - 1 - 1.1/8 - 1.3/16 - 1.1/4
1215	5/8 - 3/4 - 7/8 - 1 - 1.1/8 - 1.1/4
1610	1/2 - 5/8 - 3/4 - 7/8 - 15/16 - 1 - 1.1/16 - 1.1/8 - 1.3/16 - 1.1/4 - 1.5/16 - 1.3/8 - 1.7/16 - 1.1/2 - 1.5/8
1615	1/2 - 5/8 - 3/4 - 7/8 - 1 - 1.1/8 - 1.1/4 - 1.3/8 - 1.7/16 - 1.1/2 - 1.5/8
2012	5/8 - 3/4 - 7/8 - 15/16 - 1 - 1.1/8 - 1.3/16 - 1.1/4 - 1.5/16 - 1.3/8 - 1.7/16 - 1.1/2 - 1.5/8 - 1.3/4 - 1.7/8 - 1.15/16 - 2
2517	3/4 - 7/8 - 15/16 - 1 - 1.1/8 - 1.1/4 - 1.3/8 - 1.7/16 - 1.1/2 - 1.5/8 - 1.11/16 - 1.3/4 - 1.7/8 - 1.15/16 - 2 - 2.1/8 - 2.3/16 - 2.1/4 - 2.3/8 - 2.1/2
3020	1.1/4 - 1.3/8 - 1.1/2 - 1.5/8 - 1.11/16 - 1.3/4 - 1.7/8 - 2 - 2.1/8 - 2.3/16 - 2.1/4 - 2.3/8 - 2.7/16 - 2.1/2 - 2.5/8 - 2.11/16 - 2.3/4 - 2.7/8 - 2.15/16 - 3
3030	1.1/4 - 1.3/8 - 1.1/2 - 1.5/8 - 1.3/4 - 1.7/8 - 2 - 2.1/8 - 2.1/4 - 2.3/8 - 2.1/2 - 2.5/8 - 2.11/16 - 2.3/4 - 2.7/8 - 3
3525	1.1/2 - 1.5/8 - 1.3/4 - 1.7/8 - 2 - 2.1/8 - 2.1/4 - 2.3/8 - 2.1/2 - 2.5/8 - 2.3/4 - 2.7/8 - 3 - 3.1/8 - 3.1/4 - 3.3/8 - 3.1/2 - 3.3/4 - 4
3535	1.1/2 - 1.5/8 - 1.3/4 - 1.7/8 - 2 - 2.1/8 - 2.1/4 - 2.3/8 - 2.1/2 - 2.5/8 - 2.3/4 - 2.7/8 - 3 - 3.1/8 - 3.1/4 - 3.3/8 - 3.1/2
4030	1.3/4 - 1.7/8 - 2 - 2.1/8 - 2.1/4 - 2.3/8 - 2.1/2 - 2.5/8 - 2.3/4 - 2.7/8 - 3 - 3.1/8 - 3.1/4 - 3.3/8 - 3.1/2 - 3.3/4 - 4 - 4.1/4 - 4.1/2
4040	1.3/4 - 1.7/8 - 2 - 2.1/8 - 2.1/4 - 2.3/8 - 2.1/2 - 2.5/8 - 2.3/4 - 2.7/8 - 3 - 3.1/8 - 3.1/4 - 3.3/8 - 3.1/2 - 3.3/4 - 3.15/16 - 4
4535	2.1/4 - 2.3/8 - 2.1/2 - 2.5/8 - 2.3/4 - 2.7/8 - 3 - 3.1/8 - 3.1/4 - 3.3/8 - 3.1/2 - 3.3/4 - 4 - 4.1/4 - 4.1/2 - 4.3/4 - 5
4545	2.1/4 - 2.3/8 - 2.1/2 - 2.5/8 - 2.3/4 - 2.7/8 - 3 - 3.1/8 - 3.1/4 - 3.3/8 - 3.1/2 - 3.3/4 - 4 - 4.1/4 - 4.1/2
5050	3 - 3.1/8 - 3.1/4 - 3.1/2 - 3.3/4 - 4 - 4.1/4 - 4.1/2 - 4.3/4 - 5

NORMA DE CHAVETERO		
Diámetro	Ancho	Profun.
de 1/2 a 9/16	1/8	1/16
de 5/8 a 7/8	3/16	3/32
de 15/16 a 1	1/4	1/16
de 3/4 a 7/8	3/16	3/32
de 15/16 a 1 1/4	1/4	1/8
de 1 1/16 a 1 1/8	1/4	1/16
de 1 3/16 a 1 1/4	1/4	1/8
de 1 5/16 a 1 3/8	5/16	5/32
de 1 7/16 a 1 1/2	3/8	3/16
de 1 9/16 a 1 5/8	3/8	1/8
de 1 7/16 a 1 3/4	3/8	3/16
de 1 13/16 a 1 7/8	1/2	1/4
de 1 15/16 a 2	1/2	3/16
de 1 13/16 a 2 1/4	1/2	1/4
de 1 15/16 a 2 1/4	1/2	1/4
de 2 5/16 a 2 1/2	5/8	3/16
de 2 5/16 a 2 3/4	5/8	5/16
de 2 13/16 a 3	3/4	1/4
de 2 13/16 a 3 1/4	3/4	3/8
de 3 5/16 a 3 1/2	7/8	1/4
de 3 5/16 a 3 5/8	7/8	7/16
de 3 5/16 a 3 3/4	7/8	7/16
de 3 11/16 a 3 3/4	7/8	1/4
de 3 13/16 a 4	1	1/4
de 3 13/16 a 4 1/4	1	1/2
de 4 5/16 a 4 1/2	1	1/4
de 4 9/16 a 5	1 1/4	7/16

FACTORES IMPORTANTES PARA ELEGIR ACOPLAMIENTO

TIPO DE MAQUINA · CARACTERISTICAS DE LA APLICACION FACTOR DE SERVICIO

CARACTERISTICAS DE MONTAJE SEGUN APLICACIONES

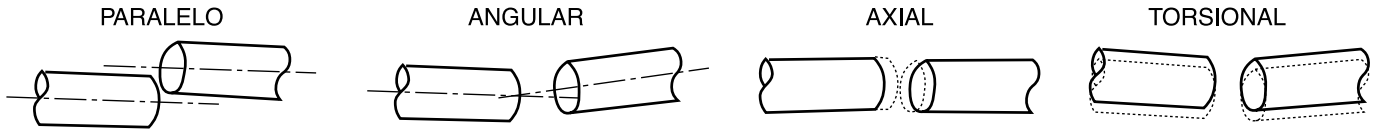

FACTORES DE SERVICIO

CASOS ESPECIALES Para aplicaciones en condiciones de trabajo con choques, vibraciones y fluctuaciones (bombas de pistones, compresores, etc.), contactar con toda la información de la máquina para que sea analizado.	TIPO DE MAQUINA MOTRIZ					
	MOTORES ELECTRICOS TURBINA DE VAPOR			M. COMBUSTION INTERNA, TURBINA DE VAPOR, TURBINA DE AGUA		
	HORAS TRABAJADAS AL DIA					
TIPO DE MAQUINA	Hasta 10	De 10 a 16	Desde 16	Hasta 10	De 10 a 16	Desde 16
Clase 1: Agitadores, compresores, centrífugos y bombas, dinamómetros, cintas transportadoras, empaquetadoras, filtros de aire, ventiladores centrífugos, generadores.	0,8	0,9	1,0	1,3	1,4	1,5
Clase 2: Maquinaria herramienta, maquinaria para la madera, bombas rotativas, mezcladores, pantallas rotativas, maquinaria téxtil.	1,3	1,4	1,5	1,8	1,9	2,0
Clase 3: Aparatos elevadores, machacadoras, compresores rotativos, dragas, hornos rotativos, prensas de ladrillos, prensas de corte, calandras.	1,8	1,9	2,0	2,3	2,4	2,5
Clase 4: Transportadores recíprocos, máquinas para el caucho, machacadoras rotativas, molinos, pantallas vibratorias.	2,3	2,4	2,5	2,8	2,9	3,0

FORMULA DE CALCULO

1 Kw = 1,36 CV	$\frac{9.555 \times Kw}{r.p.m.} = \text{Par (Nm)}$	$\frac{7.162 \times CV}{r.p.m.} = \text{Par (mkp)}$	$Kw = \frac{\text{Par (Nm)} \times r.p.m.}{9.555}$	$CV = \frac{\text{Par (mkp)} \times r.p.m.}{716,2}$
1 CV = 0,736 Kw				

