

El acoplamiento RB se emplea en la construcción de maquinaria en general. Posee una gran elasticidad torsional.

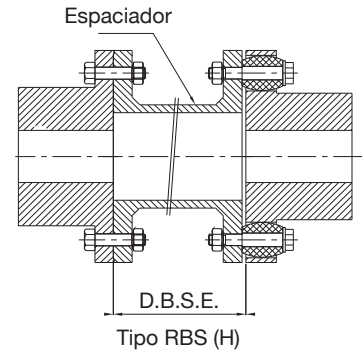

DIMENSIONES Y CARACTERÍSTICAS TÉCNICAS

Tipo	Par nominal (Nm)			Max rpm	Agujero min	Agujero Max.		ØA	ØD1	ØD2	L	S	Kg.	Desalineamiento Max.			DBSE
	NBR	Urethano	Hytrel			ØB1	ØB2							Axial m	Radial mm	Angular mm	
RB-105-3	96	143	230	7200	11	30	32	105	48	50	45	2-6	2,5	2	0,3	1°	100
RB-116-4	143	220	366	6100	12	39	42	116	60	68	45	2-6	3,6	2	0,3	1°	
RB-125-4	162	248	417	5500	14	45	50	125	68	78	50	2-6	4,8	2	0,4	1°	
RB-144-6	315	478	796	4900	18	50	60	144	82	91	55	2-6	4,3	2	0,4	1°	
RB-162-6	526	789	1314	4500	22	60	65	162	89	100	60	2-6	9,8	2	0,4	1°	
RB-178-6	640	965	1608	3800	24	70	75	178	105	115	70	2-6	13,5	2	0,5	1°	
RB-198-10	1242	1873	3121	3400	28	80	90	198	124	135	80	2-6	19,4	2	0,5	1°	140
RB-228-11	2007	3077	5128	3000	28	90	100	228	133	146	90	4-10	28	3	0,6	1°	
RB-252-12	3058	4606	7676	2700	38	105	115	252	156	167	100	4-10	38,5	3	0,6	1°	
RB-285-11	4586	6832	11386	2400	48	115	125	285	170	186	110	4-10	53,2	3	0,7	1°	180
RB-320-12	6115	9154	15256	2100	55	125	135	320	196	212	125	4-10	74,5	3	0,7	1°	
RB-360-11	8886	13358	22263	1900	65	135	150	360	212	232	140	4-12	106	4	0,9	1°	140-180
RB-400-10	12039	18084		1700	75	160	160	410	230	230	160	4-12	140	4	1,1	1°	
RB-450-12	18632	27920		1500	85	180	180	450	260	260	180	4-12	160	4	1,1	0,5°	CONSULTAR
RB-500-14	25799	38723		1350	95	200	200	500	290	290	200	4-12	250	4	1,1	0,4°	
RB-560-10	31054	46533		1200	95	225	225	560	320	320	220	4-8	380	2	1,5	0,3°	
RB-630-12	42042	63031		1050	100	250	250	630	355	355	240	4-8	365	2	1,5	0,3°	
RB-710-12	75007	112564		950	100	260	260	710	385	385	260	5-9	516	2	1,8	0,3°	
RB-800-14	100041	150090		850	100	280	280	800	420	420	290	5-9	691	2	1,8	0,3°	
RB-900-16	155078	232632		750	100	305	305	900	465	465	320	5-9	927	2	1,8	0,3°	
RB-1000-18	195113	292670		680	125	320	320	1000	515	515	350	5-10	1224	2	2	0,11	
RB-1120-18	270120			600	135	350	350	1120	560	560	380	6-11	1584	2	2,2	0,1°	
RB-1250-20	345222			550	150	380	380	1250	610	610	420	6-11	2070	2	2,4	0,1°	
RB-1400-20	530303			490	175	440	440	1400	700	700	480	6-12	3060	2	2,7	0,1°	
RB-1600-24	750450			430	200	480	480	1600	770	770	540	6-12	3960	2	3	0,1°	
RB-1800-22	975566			380	225	540	540	1800	870	870	600	8-16	5760	2	3,4	0,1°	
RB-2000-26	1300818			340	250	600	600	2000	960	960	650	8-16	7020	2	3,8	0,1°	

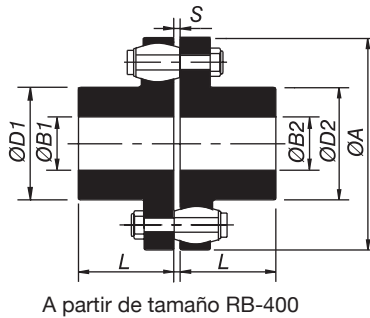
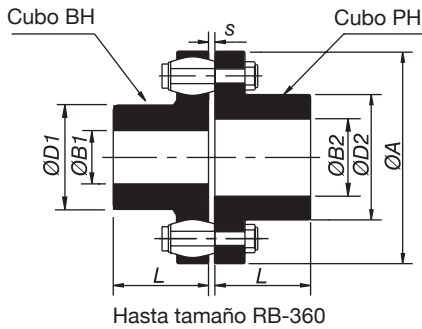