

SERIE QUADRA-FLEX

El acoplamiento QUADRA-FLEX es adecuado en condiciones de trabajo con choques, vibraciones y desalineamientos.

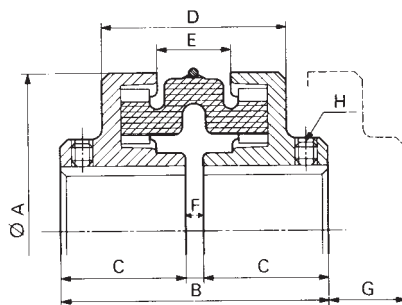

Tipo S

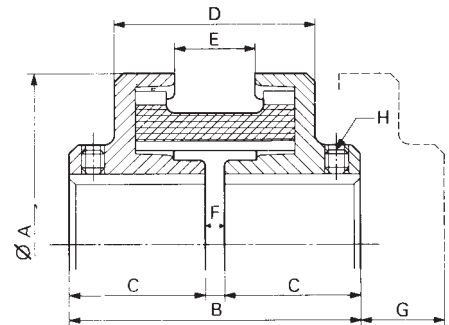

Tipo J

DIMENSIONES

Tipo	Agujero máx.	Dimensiones (mm)						Peso (kg)
		A	B	C	D	E+ΔE	H	
J3	22	52	53	20,5	32	12±1	M5	0,25
J4	25	62	62	22	39	18±1	M6	0,50
J5	32	83	76	27	48	22±1,5	M6	0,95

Tipo	Agujero		Dimensiones (mm)								Peso (kg)
	mín.	máx.	Ø A	B	C	D	E+ΔE	F	G	H	
S5	13	32	83	72	34	48	22±1,5	7	23	M6	0,95
S6	16	40	103	92	41	61	26±1,5	10	28	M8	2,30
S7	16	48	120	104	47	70	30±2	10	33	M8	3,40
S8	19	55	139	117	53	79	33±2	11	38	M10	5,30
S9	22	65	164	133	61	93	40±2	11	45	M10	8,10
S10	32	75	196	149	68	108	46±2,5	11	51	M12	13
S11	38	85	231	186	87	129	53±2,5	12	60	M16	22
S12	38	95	268	215	100	143	64±3	15	66	M16	34
S13	45	110	310	240	110	173	73±3	20	78	M16	50
S14	51	120	360	256	115	202	88±3	26	88	M16	71
S16	51	150	492	367	150	265	125±4	67	108	M20	165

TEMPERATURA: NEOPRENO: -18° + 93°C
 EPDM: -34° + 135°C
 HYTREL: -54° + 120°C

CARACTERÍSTICAS

Tipo	EPDM - NEOPRENO		HYTREL	
	Torque Nm	Máx. R.P.M.	Torque Nm	Máx. R.P.M.
3	7	9200	N/A	N/A
4	14	7600	N/A	N/A
5	27	7600	N/A	N/A
6	51	6000	203	6000
7	82	5250	325	5250
8	128	4500	512	4500
9	203	3750	813	3750
10	325	3600	1282	3600
11	512	3600	2034	3600
12	813	2800	3559	2800
13	1282	2400	5340	2400
14	2034	2200	8189	2200
16	5340	1500	N/A	N/A



JEM - JN



EM - E - N



JEMS - JNS



H - HS