



Product portfolio

# KettenWulf Roller chains

for drive and conveyor applications

- » Drop forged rivetless chains
- » Welded steel chains

- » Product catalogue
- » Special solutions
- » Spare parts

# The global KettenWulf Group



The core factory in Kückelheim, corporate headquarters and KettenWulf competence centre

## Table of contents

<b>02 The global KettenWulf Group</b>	66 BNMC roller chains (additional plastic plates)
<b>04 KettenWulf – Partner of industries</b>	68 SF Accumulation chains
<b>06 Conveyor chains, drive chains and sprockets</b>	72 Elastomer profile chains
<b>08 The new generation of KW roller chains</b>	76 S agricultural machinery chains
09 The design of a roller chain	78 Deep links chains
10 Standard packing units	80 CC side-flexing conveyor chain
11 Connecting links for roller chains	
12 Customisation of roller chains	<b>82 WSC – welded steel chains</b>
<b>14 Service life of chains</b>	84 WSC chains WR/WH/WHX
<b>17 Research and development</b>	88 WSC chains WDH/WDR
<b>19 Products</b>	90 WSC chains WHX HD
<b>20 Drive chains</b>	<b>92 Drop forged rivetless chains</b>
22 British standard roller chains DIN 8187	93 Standard Drop forged chains
26 Attachments for roller chains	94 Premium Drop forged chains
31 American standard roller chains DIN 8188	95 Attachments for Drop forged chains
34 HS roller chains (heavy series)	100 Trolleys for Drop forged chains
36 HFS roller chains	
42 NSC roller chains (factory standard)	<b>108 Hollow pin chains</b>
44 Rotary chains	110 HP – hollow pin chains
<b>46 Roller chains for special purposes</b>	114 1650HP chains
48 SS roller chains (stainless steel)	116 DP-HP chains
50 NP roller chains (nickel plated)	118 BS-HP chains
52 TGI roller chains (special coated)	<b>120 Roller chains for the wood industry</b>
54 LF roller chains (lube free)	122 Chains for log transport
<b>58 Roller chains for conveyor applications</b>	126 Chains for sawing lines and wood-board transport
60 C roller chains (straight plates)	140 Chains for the wood-processing industry
64 DP roller chains (double pitch, straight plate)	<b>142 Spare parts</b>



**Figure top left:**  
Warehouse in Kückelheim, Germany



**Figure top right:**  
Production and sales site in Ferlach, Austria



**Figure bottom left:**  
Production and sales site in Hangzhou, China



**Figure bottom right:**  
Warehouse and sales site near Atlanta, USA



As an internationally expanding company, KettenWulf represents quality, reliability and flexibility for more than 90 years. Since its foundation by the brothers Josef and Johannes Wulf in 1925 the company has been managed by the Wulf family.

Starting out as a manufacturer of articulated chains, it developed over nine decades into a modern global company whose heart and roots remain in the Sauerland region. More than 1400 employees develop, produce and distribute individual solutions in conveying and drive technology at nine locations in Europe, America, Asia and Australia.

The core factory at Kückelheim not only houses the corporate headquarters but also the KettenWulf competence centre. This looks after customers worldwide regarding technical queries. With a production area of 30,000 m<sup>2</sup> and approx. 550 employees, Kückelheim is the largest production site of the KettenWulf Group worldwide.

Offering top product quality, KettenWulf is your local strategic partner anywhere in the world. Whether in the Sauerland, in Hangzhou, Sydney or Atlanta: With our global network we support you internationally. With global technical support and personal contact our employees support you all the way.

Trust, commitment and loyalty – those are the values KettenWulf lives as a family-run company. As a medium-sized enterprise our corporate structure is based on trust with strong personal relationships with both our customers and suppliers.

## KettenWulf – Partner of industries



Excellent quality and numerous possible applications are what characterise KettenWulf products as premium products. Our versatile chains are used in a variety of industries. Almost every industrial sector benefits from our know-how as a supplier for complete chain systems.

KettenWulf offers a number of highly specialised areas of expertise to support your projects. We have linked all individual services efficiently to obtain optimum results for your product solutions.





We are by your side as a competent partner: From the initial consultation and an intensive support of the value creation process to the review of existing resources.



#### **Development:**

We develop and design the best possible conveyor and drive engineering solutions corresponding to your needs and requirements.

#### **Production:**

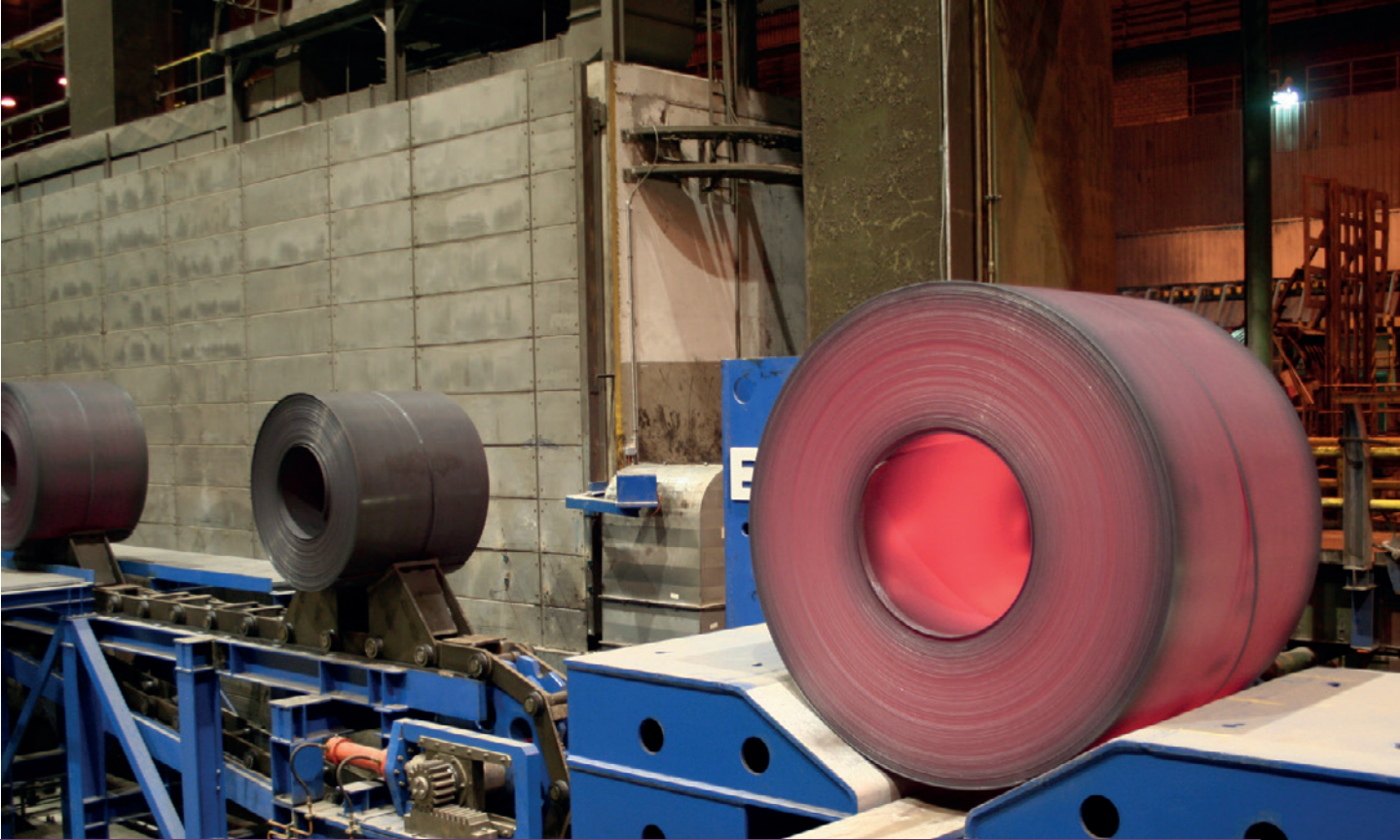
We use state-of-the-art technology to manufacture special conveyor chains, drive chains and sprockets for you.

#### **Installation:**

If you wish, our reliable and trustworthy partners can handle your on-site installation work.

#### **After-sales:**

Upon request, we can inspect and check the condition of your chains and sprockets with respect to their functional capability and remaining service life.



## Conveyor chains, drive chains and sprockets

We develop and produce special-purpose conveyor chains and transport chains of all types and dimensions, as well as DIN, ISO and ANSI-compliant chains. Irrespective of the conveyance task, be it automotive production or the transport of bulk material or the wood-pressing industry – KettenWulf has the right solution.

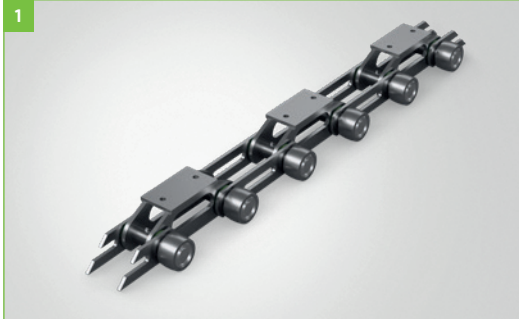
We offer a wide range of drive chains in all DIN sizes and in accordance with all international standards for any type of application. Whether you need a chain for intense long-term load or with high resistance to environmental influences – KettenWulf has the right solution.

Sprockets are a decisive factor for the capacity and service life of every chain system. Our range of products includes sprockets with all types of standard toothing and, of course, custom-made solutions.

Whether you need sprockets manufactured from high-grade materials, with specially tempered or induction hardened tooth gaps – KettenWulf has the right solution.



**Figure 1:**  
Oil-tight reclaimer chain  
with SCS PO



## Conveyor chains

**Figure 2:**  
HFS roller chain



## Drive chains

**Figure 3:**  
Sprocket with noise  
reduction system



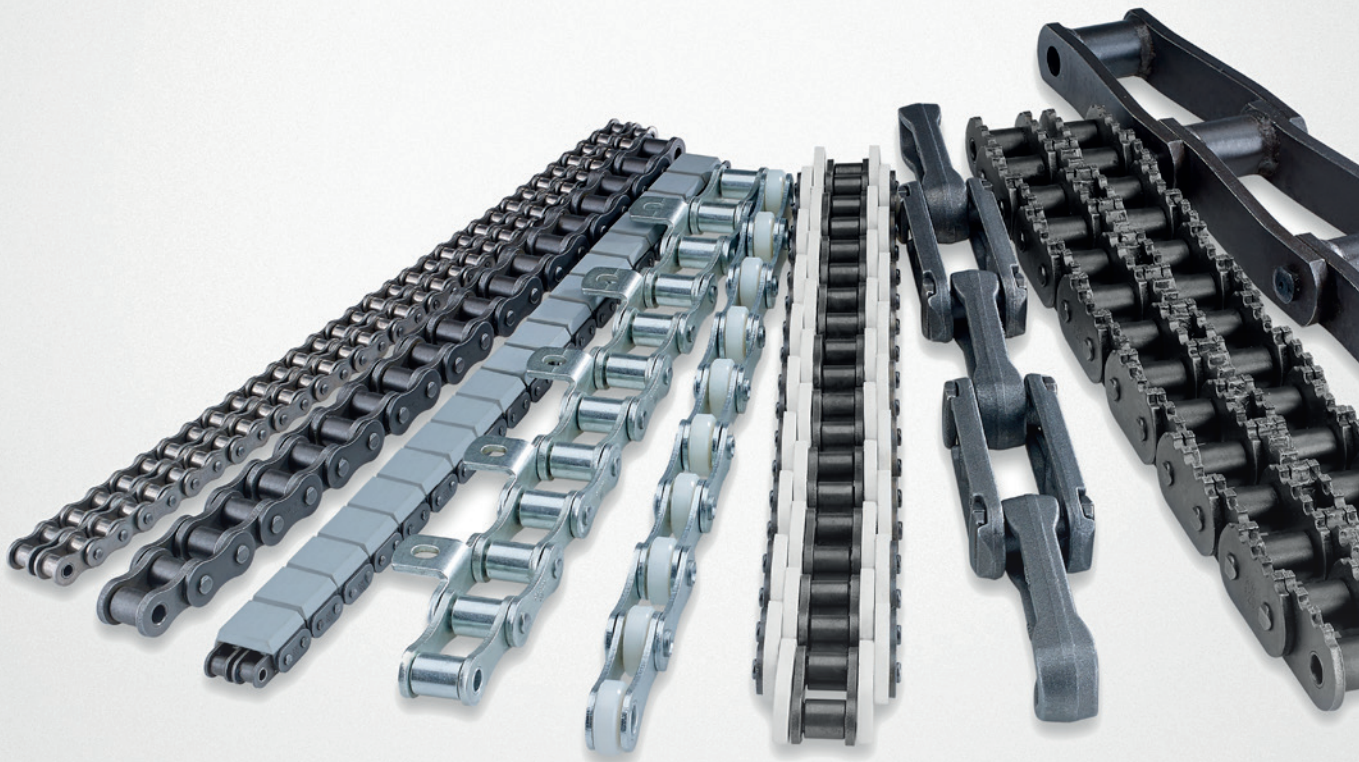
## Sprockets

**Figure 4:**  
Drive shaft unit for  
the escalator chain  
industry



## Components

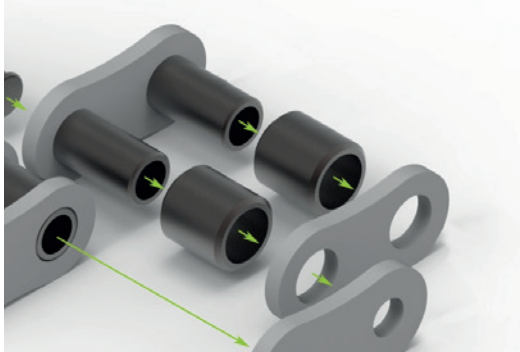
## The new generation – KettenWulf roller chains



For KettenWulf the concept of innovation means making very good products even better. In order to meet the ever-increasing requirements in the field of drive technology in a sustainable manner we have reconciled the entire roller chain product portfolio under the brand name of "KettenWulf" giving priority to the optimisation of our products' quality.

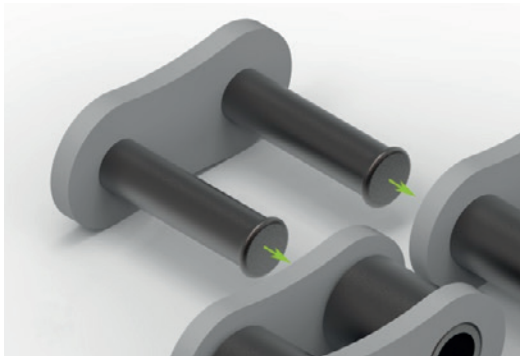


## The design of a roller chain



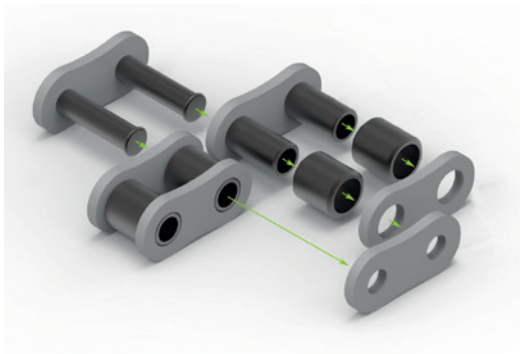
### Inner link of a roller chain

The inner link of a roller chain consists of two inner plates, two press-fit bushes and two rollers rotating on the bushes.



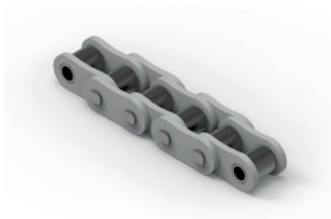
### Outer link of the roller chain

The outer link is composed of two outer plates and two pins. The pins are pressed into the holes of the outer plates with high pressure forming a friction-type contact between these elements which will not slacken even under heavy and continuing impacts.



The inner links are connected by the outer links by passing the pins through the bushes of the inner link and riveting them to the two outer link plates.

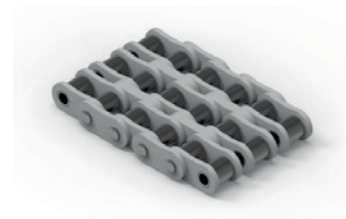
We distinguish between three different types of design: simple, double and triple roller chains. We also call these three designs simplex, duplex and triplex roller chains.



Simplex roller chain



Duplex roller chain



Triplex roller chain

## Standard packing units of the roller chains

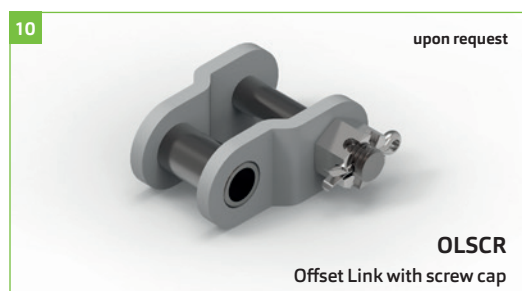
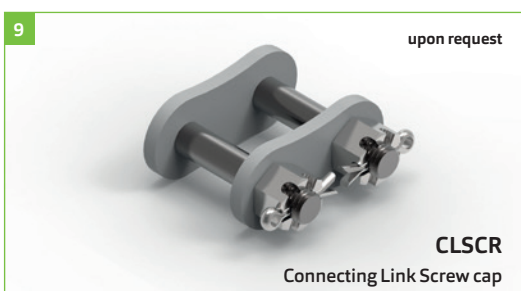
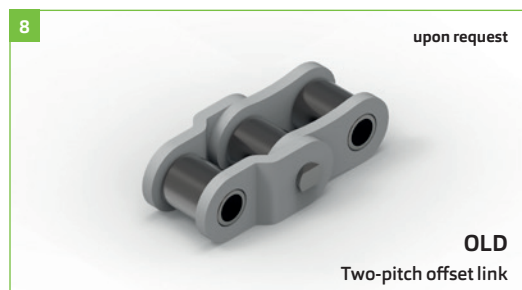
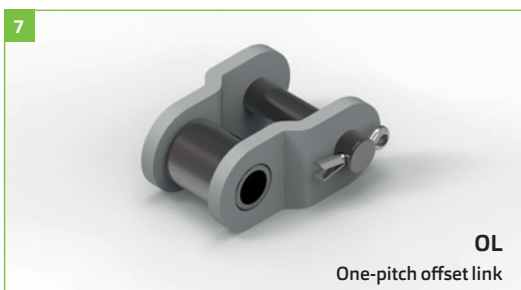
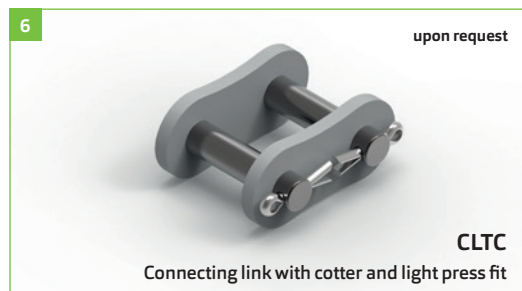
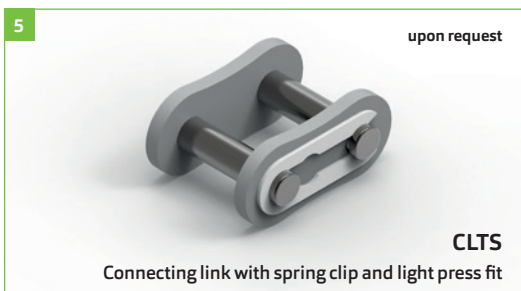
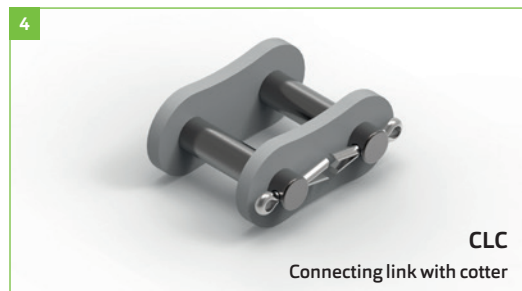
Box (meters)							
Pitch		Simplex Content: Number of meters including 2 CL		Duplex Content: Number of meters including 2 CL		Triplex Content: Number of meters including 2 CL	
mm	inch	Links	Length	Links	Length	Links	Length
6.000	–	831 + 2 CL	4.998 m	831 + 2 CL	4.998 m	831 + 2 CL	4.998 m
6.350	1/4"	785 + 2 CL	4.997 m	785 + 2 CL	4.997 m	785 + 2 CL	4.997 m
8.000	–	623 + 2 CL	5.000 m	623 + 2 CL	5.000 m	623 + 2 CL	5.000 m
9.525	3/8"	523 + 2 CL	5.001 m	523 + 2 CL	5.001 m	523 + 2 CL	5.001 m
12.700	1/2"	391 + 2 CL	4.991 m	391 + 2 CL	4.991 m	391 + 2 CL	4.991 m
15.875	5/8"	313 + 2 CL	5.001 m	313 + 2 CL	5.001 m	313 + 2 CL	5.001 m
19.050	3/4"	261 + 2 CL	5.010 m	261 + 2 CL	5.010 m	261 + 2 CL	5.010 m
25.400	1"	195 + 2 CL	5.004 m	195 + 2 CL	5.004 m	195 + 2 CL	5.004 m
31.750	1 1/4"	155 + 2 CL	4.985 m	155 + 2 CL	4.985 m	155 + 2 CL	4.985 m
38.100	1 1/2"	129 + 2 CL	4.991 m	129 + 2 CL	4.991 m	129 + 2 CL	4.991 m
44.450	1 3/4"	111 + 2 CL	5.023 m	111 + 2 CL	5.023 m	111 + 2 CL	5.023 m
50.800	2"	97 + 2 CL	5.029 m	97 + 2 CL	5.029 m	97 + 2 CL	5.029 m
57.150	2 1/4"	85 + 2 CL	4.972 m	85 + 2 CL	4.972 m	85 + 2 CL	4.972 m
63.500	2 1/2"	77 + 2 CL	5.017 m	77 + 2 CL	5.017 m	77 + 2 CL	5.017 m
76.200	3"	63 + 2 CL	4.953 m	63 + 2 CL	4.953 m	63 + 2 CL	4.953 m

Box (feet)							
Pitch		Simplex Content: in feet, including 1 CL		Duplex Content: in feet, including 1 CL		Triplex Content: in feet, including 1 CL	
mm	inch	Links	Length	Links	Length	Links	Length
6.350	1/4"	479 + 1	10 ft	479 + 1	10 ft	479 + 1	10 ft
9.525	3/8"	310 + 1	10 ft	319 + 1	10 ft	319 + 1	10 ft
12.700	1/2"	239 + 1	10 ft	239 + 1	10 ft	239 + 1	10 ft
15.875	5/8"	191 + 1	10 ft	191 + 1	10 ft	191 + 1	10 ft
19.050	3/4"	159 + 1	10 ft	159 + 1	10 ft	159 + 1	10 ft
25.400	1"	119 + 1	10 ft	119 + 1	10 ft	119 + 1	10 ft
31.750	1 1/4"	95 + 1	10 ft	95 + 1	10 ft	95 + 1	10 ft
38.100	1 1/2"	79 + 1	10 ft	79 + 1	10 ft	79 + 1	10 ft
44.450	1 3/4"	69 + 1	10 ft	69 + 1	10 ft	69 + 1	10 ft
50.800	2"	59 + 1	10 ft	59 + 1	10 ft	59 + 1	10 ft
63.500	2 1/2"	49 + 1	10 ft	49 + 1	10 ft	49 + 1	10 ft

» For available length supplied on a reel please refer to page 139



# Connecting links for roller chains



# Customisation of the roller chains

In order to cut your roller chain to the desired length we require the following information:

## 1. Specify the chain type

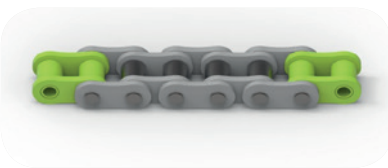
**Chain**  
 Standard designation, e.g. KW 16B

- » Pitch
- » Inner width between the inner links
- » Roller Ø
- » Pin Ø

## 2. Specify the number of links (without connecting link!)

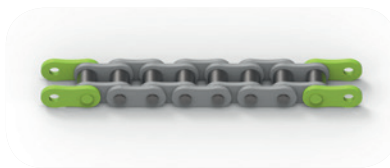
**odd number of links  
inside/inside**

(starting with an inner link and ending on an inner link)



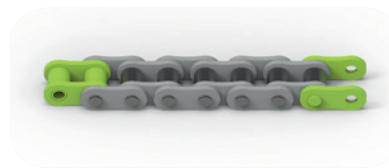
**odd number of links  
outside/outside**

(starting with an outer link and ending on an outer link)



**even number of links  
inside/outside**

(starting with an inner link and ending on an outer link)



### 3. Select the type of connecting link

**Standard connecting links available**



(refer to page 11 for an example)

**No connecting links**



**Cranked connecting link**



When using cranked connecting links, the expected breaking load is only 80%.

### 4. Select the delivery option

**Deliver connecting link separately**

**Deliver without closing link, open chain**

**Deliver cranked offset link, separately**

Even number of links (with standard closing link)

**Deliver with connecting link mounted, open chain**



**Deliver connecting link mounted, continuous chain**



Odd/even number of links (with cranked closing link)



**Deliver cranked offset link mounted, open chain**  
(chain ends inside-inside)

**Deliver cranked offset link mounted, continuous chain**  
(to be joined by a rivet link or a closing link)



# Technology explained – the service life of chains



## Service life

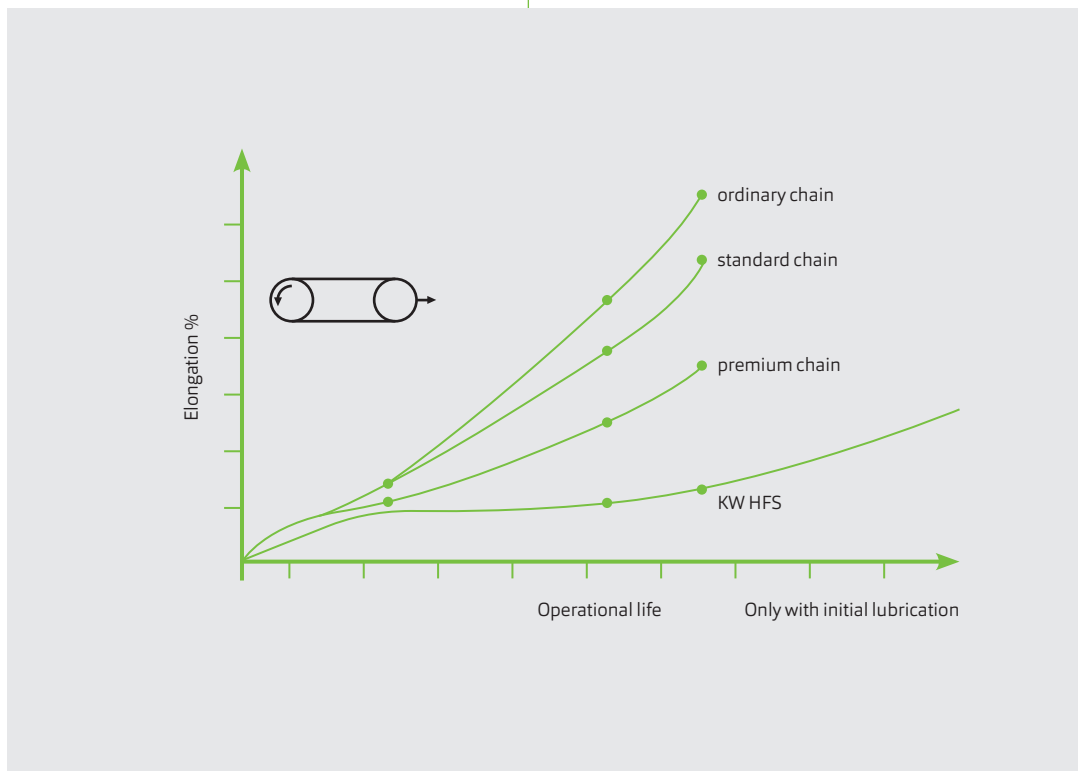
The service life is the period of time in which the roller chain is guaranteed to work without breaking and within acceptable wear standards. Generally recognized codes of practice stipulates that a chain is considered to be worn once it has gained in length by 2%. At a 1.5-% elongation the safe and reliable operation of the chain can no longer be guaranteed and there is a real risk of rupture or damage.

For protection and to ensure a high output the roller chain is no longer considered to be fit for operation once it has gained 1.5% in length.

## Wear resistance

The main reason for wear on a chain is the friction between the bush and the pin when the sprocket engages causing the chain to extend. The magnitude of the oscillating movement depends on the number of teeth on the sprocket. The lower the number of teeth, the higher the wear. Lubrication plays an important role here, too.

What makes KettenWulf roller chains resistant to wear is the high precision and the uniform finish of the seamless bushes and the perfect roundness of the pins. This is complemented by an optimal selection of case-hardened and tempered steel.



## Endurance limitation

This is a time window between the fatigue limit and the elastic limit. A chain is permanently resistant (remains solid and unchanged) for as long as the load on it remains below the fatigue limit. Beyond the fatigue limit, the chain will only sustain the load for a limited period of time.

In some cases it may be necessary to choose a chain for loads in the endurance limit range. This may be due to commercial reasons or justified by conscious under-dimensioning due to a lack of space. It is also possible that the chain falls into this endurance limit range because it was improperly selected. Within this range, the chain will only sustain the load and remain solid for a limited time before failing due to fatigue fractures after a short while. The closer the load gets to the elastic limit, the more easily the chain will break. This could happen after just a few hours.

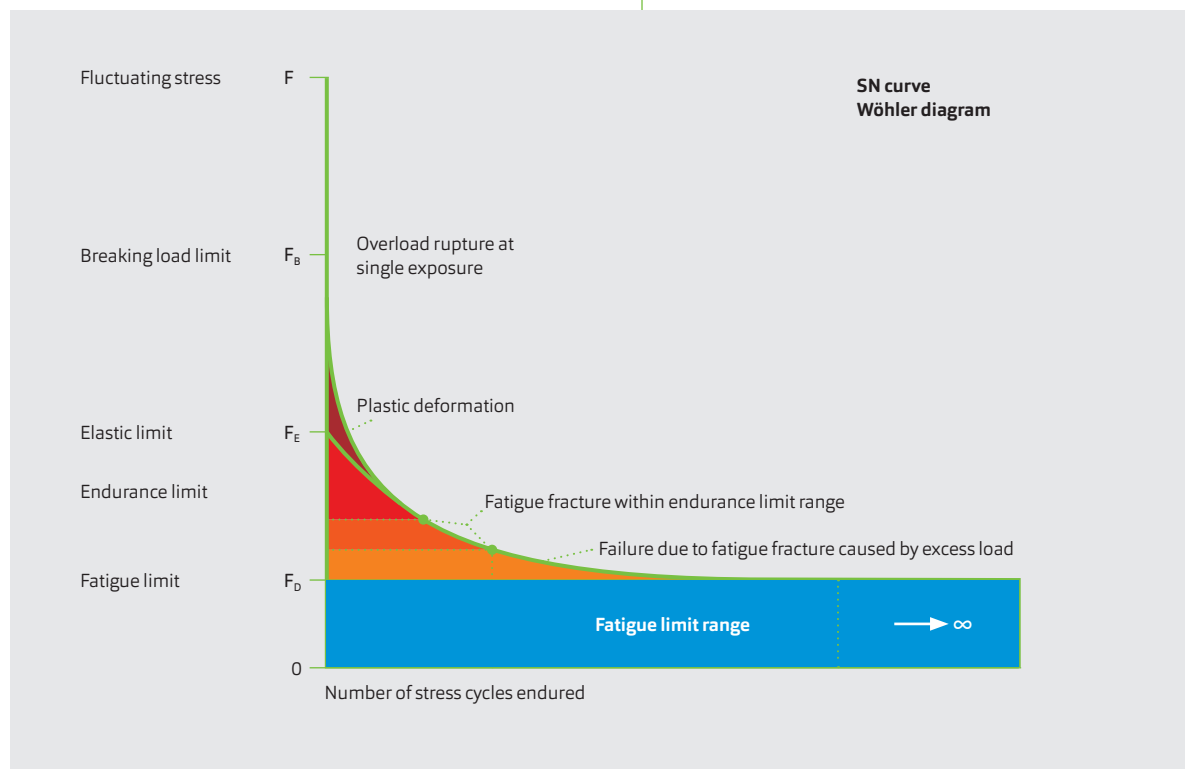
## Fatigue strength

Fatigue strength or the maximum permissible load is the limit at which the chain can barely sustain the fluctuating stress without failing due to fatigue fracture. The fatigue strength limit is determined with a fatigue test (SN curve). There is no correlation between the breaking load and the fatigue strength.

The fatigue strength of a chain is affected by production standards and quality standards and – unlike the breaking load – varies greatly between the models of the different manufacturers. The actual maximum fatigue strength values for all different KettenWulf roller chain series are available upon request! These are constantly lab-tested.

## Elastic limitation

The elastic limit ranges between the breaking load and the fatigue strength. When used below the elastic limit the chain will recover its original shape since this span falls within the elastic deformation range. Exceeding the elastic limit will result in an immediate permanent plastic deformation, the link plates are deformed and the bore holes will become oval.

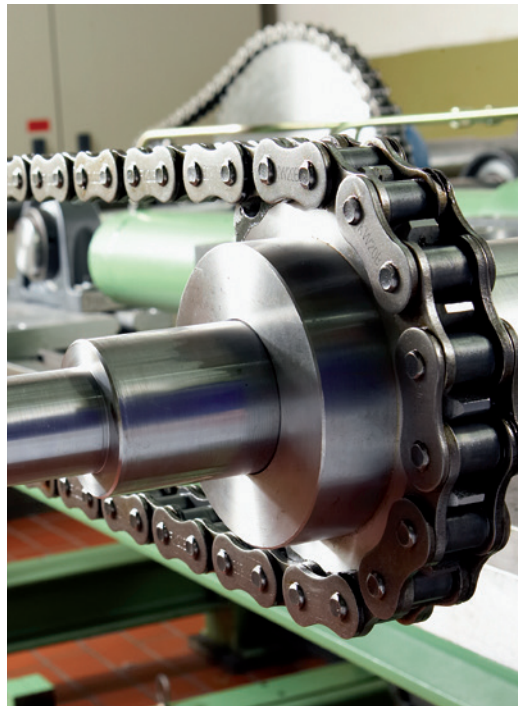




## Research and development



Fatigue strength determined with a high-frequency pulser



Roller chain test bench for life cycle testing

The satisfaction and trust of our customers are a cornerstone of the corporate philosophy of the KettenWulf Group. To guarantee the consistent high quality of our products, KettenWulf has undergone certification in accordance with the strict provisions of the standards DIN ISO 9001 and 14001.

We have implemented quality management in all production and management processes to make sure that we meet the quality requirements of our customers. From the acceptance of goods to the final inspection of the finished products, we do our best to offer our customers only the highest quality standards.

We have significantly improved the wear resistance and fatigue strength of all KettenWulf roller chains. This is achieved by:

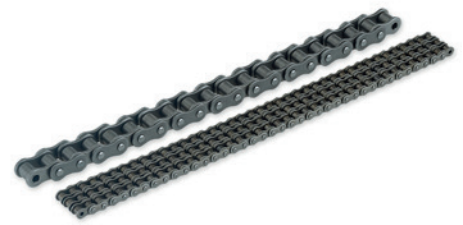
- » **high precision and dimensional accuracy**
- » **seamless rollers**
- » **cold-extruded bushes**
- » **selected high-quality chain materials**
- » **high-grade lubricants**
- » **optimised heat treatment**

These advances provide our customers with an increased production efficiency and crucial competitive advantages. Convince yourself of the high level of innovation of our products!



**For every application the  
perfect solution**

## Drive chains



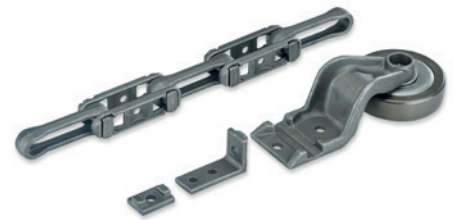
## Roller chains for special purposes



## Chains for conveyance application



## Drop-forged rivetless chains



## Hollow pin chains



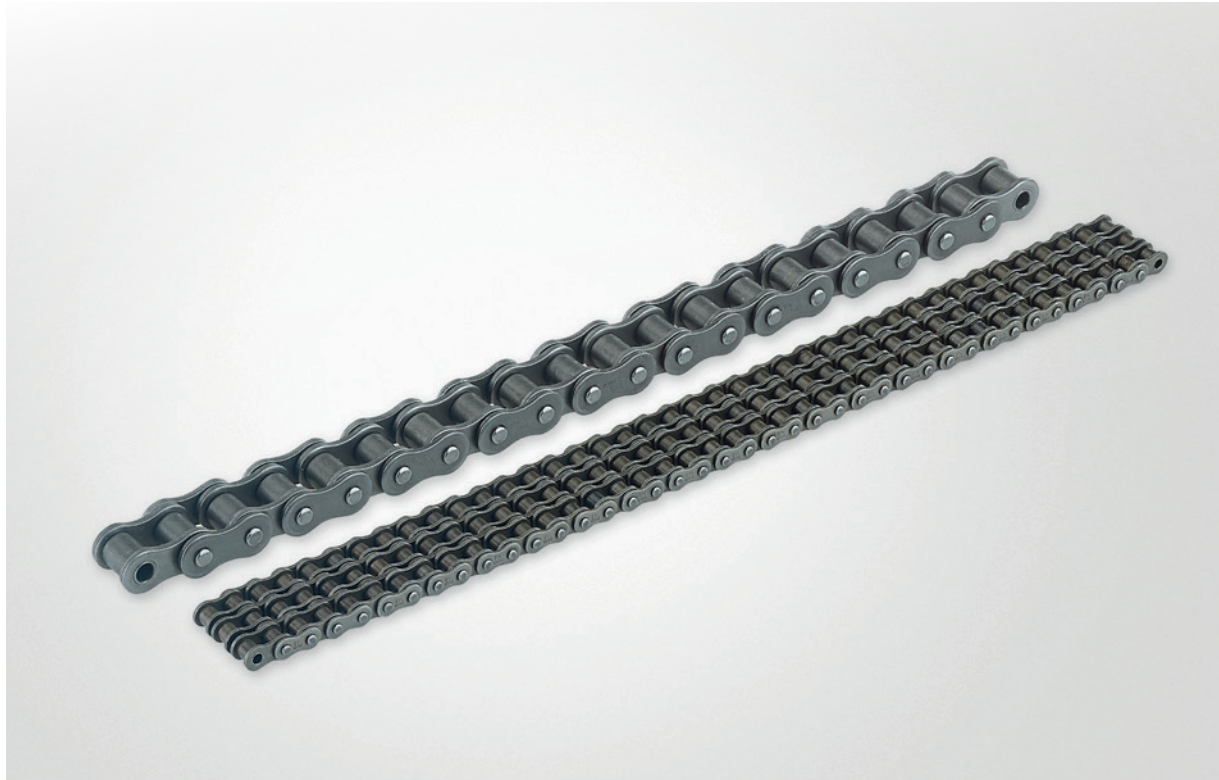
## Chains for the wood industry



## Spare parts







## Drive chains

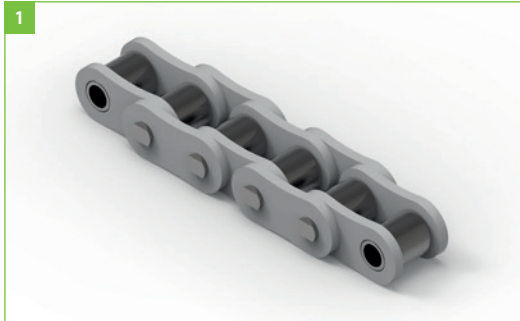
The quality requirements for roller chains are as varied as the fields of activities of our customers. Selecting a suitable product solution mainly depends on the following criteria:

- » wear resistance
- » fatigue strength
- » length precision
- » conditions of use / environmental factors
- » maintenance-free operation
- » corrosion protection
- » food-grade lubrication
- » noise reduction

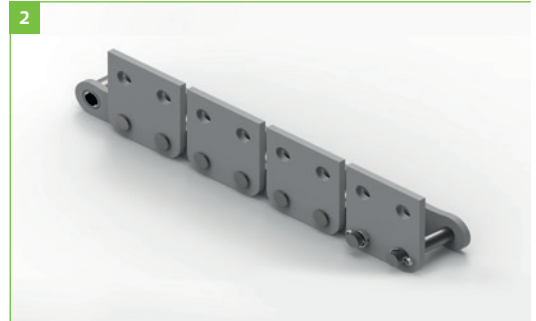
As a general rule, one chain will not satisfy all of these different criteria. This is why our products are designed in a way that allows us to offer the ideal product for every application, both from a technical and a commercial point of view. Our standard product portfolio for roller chains therefore includes a large variety of properties and different attachments.

## Specific versions of the drive chain

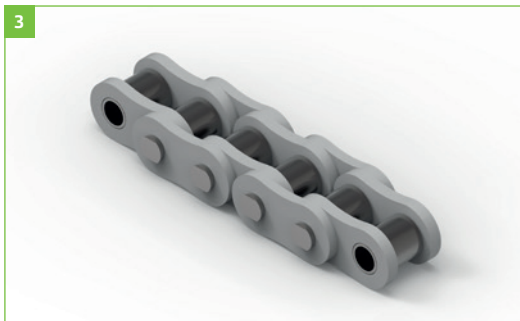
**Figure 1:**  
KW roller chain



**Figure 2:**  
Roller chain with  
attachments



**Figure 3:**  
HS roller chain



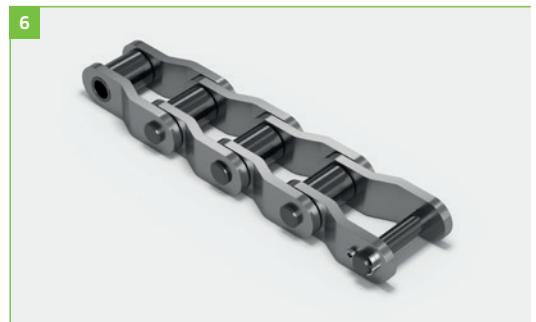
**Figure 4:**  
HFS roller chain



**Figure 5:**  
NSC roller chain

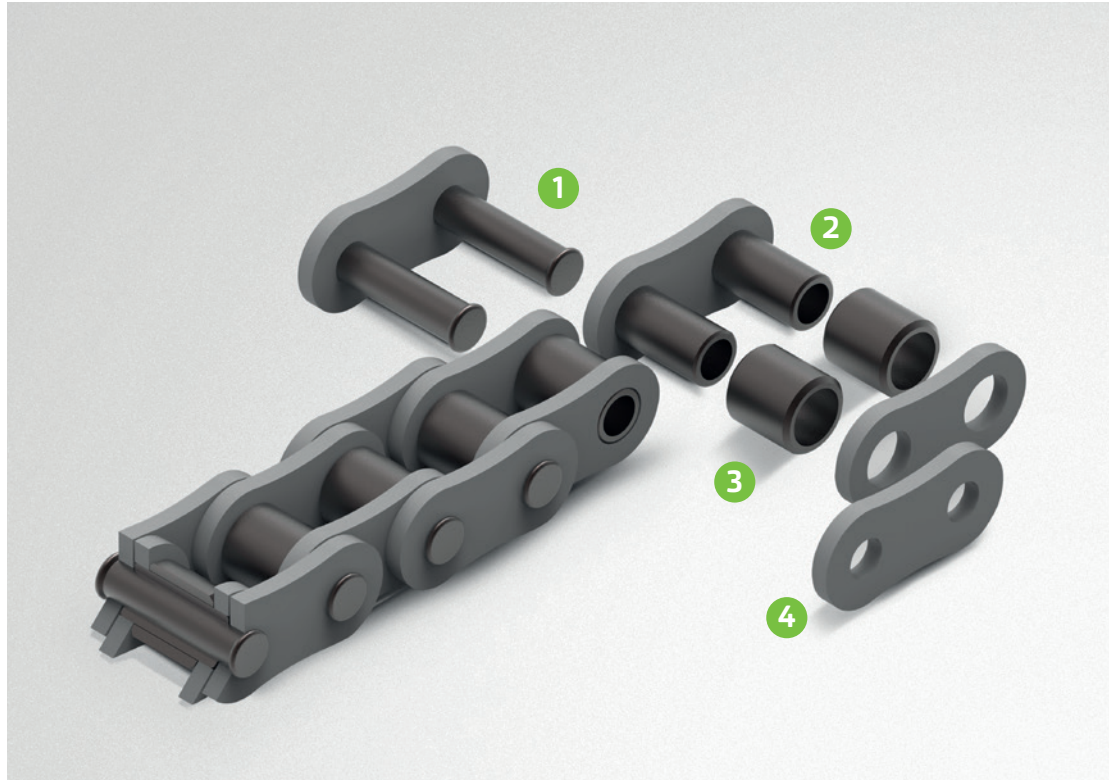


**Figure 6:**  
Rotary chain



**KW roller chain**

- ① Wear-optimised pins, case-hardened
- ② Seamless, cold-extruded bushes
- ③ Seamless, case-hardened rollers for high wear resistance
- ④ Ball-blasted link plates, quenched and tempered



## KW roller chains

The main distinguishing feature of KW roller chains as compared to standard roller chains are their seamless, cold-extruded bushes, case-hardened pins, ball-blasted, quenched and tempered link plates and through-hardened rollers. The precision of the finishing and the heat treatment of their components ensure that all components expose exceptionally good wear resistance properties and guarantee the perfect length accuracy and straightness of the chain.

The alloyed case-hardened steel used for the pins (up to 1 ½") provides good shear strength and core strength. The surface quality is further enhanced by precision-grinding, which reduces the frictional resistance between the pin and the bush.

The seamless bush guarantees optimal cylindricity. The accuracy of this is much higher than for bushes made of precision-steel pipes. This increases the length precision of the chain. The case-hardened steel used for the bushes provides high surface hardness and an optimised wear resistance. The through hardened rollers used from a size of > 5/8" ensure good shock resistance to surges caused when the chain engages in the sprocket.

Cutting-edge tools are used to accurately stamp the link plates with a particularly high proportion of clear-cut surface. Combined with the grinded pins and bushes this ensures an exceptional press fit of the links plates. Together with the strict manufacturing tolerances applied and the enhanced surface strength achieved by shot peening the components, this allows to improve the overall fatigue strength.

A wax-like initial lubricant and the default pre-stretching of the chains with >40% of the breaking load ensure that the initial wear is kept low.

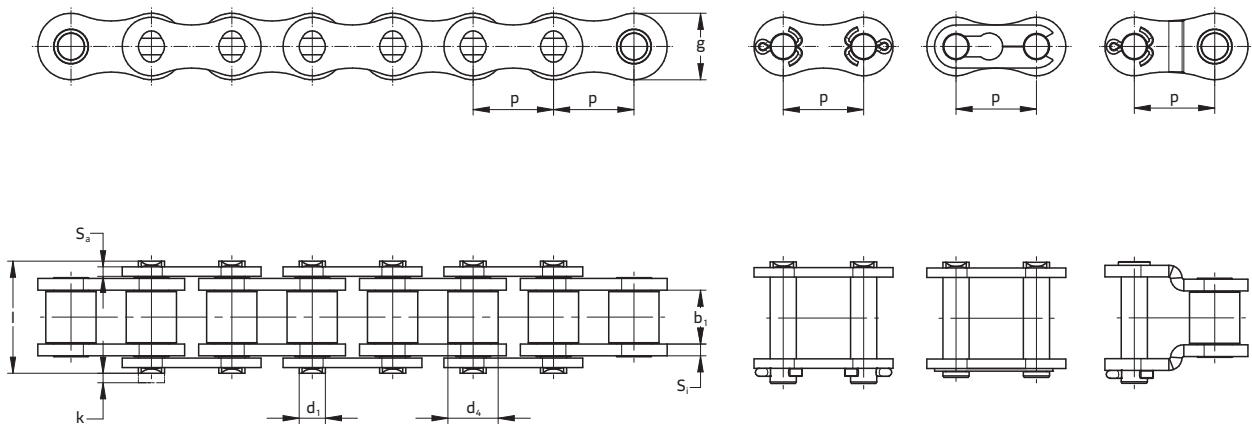
The initial lubrication of KettenWulf roller chains is conceived for an operating temperature range of -30°C to +130°C. Our many years of experience and manufacturing options in the field of conveyor chains allow us to produce roller chains which are larger than 80B. Please don't hesitate to contact us.



# DIN 8187 / ISO 606-compliant KW roller chains

## KW simplex

Drawings / product data (European standard)



### KettenWulf wear-resistant roller chains

KW simplex, sizes according to European standard

ISO 606 / DIN 8187

Designation	Pitch [mm]	Min. inner width [mm]	Max. protection roller $\varnothing$ [mm]	Max. pin $\varnothing$ [mm]	Max. pin length [mm]	Max. overhang connecting pin [mm]	Inner plate thickness [mm]	Outer plate thickness [mm]	Plate height [mm]	Bearing area [cm <sup>2</sup> ]	Min. breaking load [N]	Weight [kg/m]
Chain type	p	b <sub>1</sub>	d <sub>2</sub>	d <sub>1</sub>	l	k	S <sub>1</sub>	S <sub>2</sub>	g	f	F <sub>B</sub>	≈q
KW 04	6.000	2.80	4.00	1.85	6.80	0.50	0.63	0.65	5.00	0.08	3000	0.13
KW 05B	8.000	3.00	5.00	2.31	8.00	0.90	0.80	0.80	7.00	0.11	4500	0.18
KW 06B*	9.525	5.72	6.35	3.28	12.50	2.40	1.30	1.30	8.20	0.28	8900	0.40
KW 081**	12.700	3.60	7.75	3.66	9.60	1.30	0.96	0.96	9.90	0.26	8200	0.30
KW 083	12.700	4.88	7.75	4.08	12.40	1.10	1.30	1.30	10.40	0.32	12000	0.50
KW 084	12.700	4.88	7.75	4.09	14.30	1.30	1.80	1.60	11.10	0.33	16000	0.60
KW 08B**	12.700	7.75	8.51	4.45	16.50	1.50	1.60	1.60	11.80	0.50	17800	0.70
KW 10B**	15.875	9.65	10.16	5.08	19.60	1.40	1.70	1.70	14.70	0.67	22400	0.90
KW 12B**	19.050	11.68	12.07	5.72	22.30	2.70	1.85	1.85	16.00	0.89	28900	1.20
KW 16B**	25.400	17.02	15.88	8.28	35.60	1.60	4.00	3.00	20.90	2.10	60000	2.67
KW 20B**	31.750	19.58	19.05	10.19	40.50	3.70	4.50	3.50	26.30	2.96	95000	3.81
KW 24B**	38.100	25.40	25.40	14.63	53.30	4.70	6.00	4.80	33.30	5.54	160000	7.43
KW 28B	44.450	30.99	27.94	15.90	65.00	5.30	7.50	6.00	36.80	7.39	200000	9.47
KW 32B	50.800	30.99	29.21	17.81	65.20	5.80	7.00	6.40	42.20	8.10	250000	10.17
KW 40B	63.500	38.10	39.37	22.85	82.20	7.00	8.50	8.00	52.90	12.75	355000	17.00
KW 48B	76.200	45.70	48.20	29.20	99.00	8.00	12.00	10.00	64.00	20.61	560000	27.00
KW 56BHFS	88.900	53.34	54.00	34.30	113.00	12.00	14.00	12.00	78.00	27.90	850000	38.00
KW 64BHFS	101.600	60.96	63.50	39.40	129.00	19.00	15.00	14.00	93.30	36.25	1120000	49.50
KW 72BHFS	114.300	68.58	72.39	44.50	147.00	14.00	18.00	15.00	103.63	46.19	1400000	64.50

\* straight link plate

\*\* also available on reel from stock

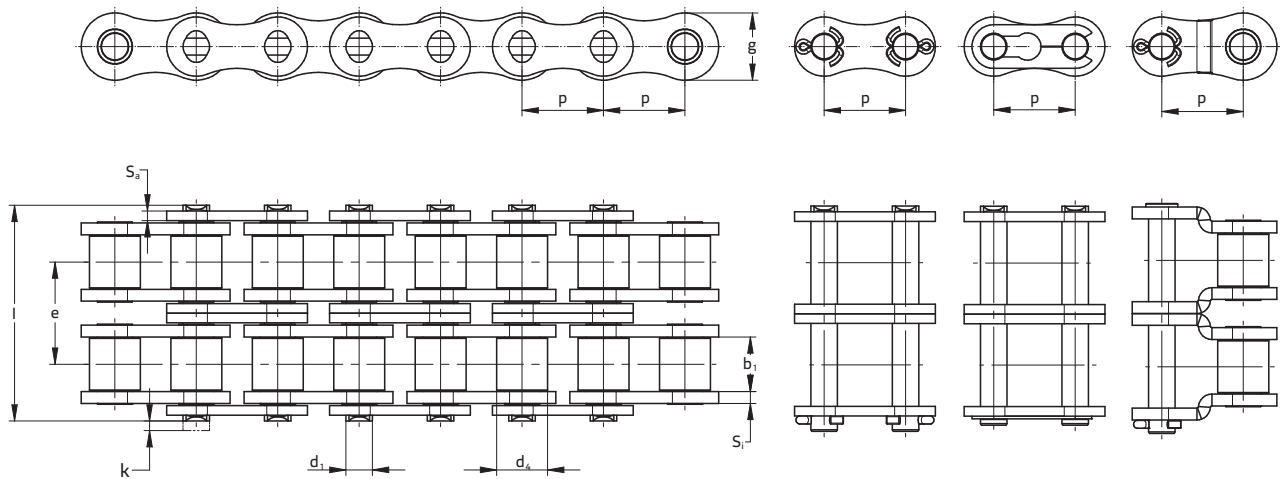
» The indicated breaking loads are those stipulated in ISO 606. We will be happy to provide you with the actual higher breaking loads upon request.

» We can also produce larger roller chains than 80B upon request.

# DIN 8187 / ISO 606-compliant KW roller chains

## KW duplex

Drawings / product data (European standard)



### KettenWulf wear-resistant roller chains

KW duplex, sizes according to European standards

ISO 606 / DIN 8187

Designation	Pitch [mm]	Min. inner width [mm]	Max. protection roller Ø [mm]	Max. pin Ø [mm]	Max. pin length [mm]	Max. overhang connecting pin [mm]	Inner plate thickness [mm]	Outer plate thickness [mm]	Plate height [mm]	Transverse pitch [mm]	Bearing area [cm <sup>2</sup> ]	Min. breaking load [N]	Weight [kg/m]
Chain type	p	b <sub>1</sub>	d <sub>2</sub>	d <sub>1</sub>	l	k	S <sub>1</sub>	S <sub>2</sub>	g	e	f	F <sub>B</sub>	≈q
KW 05B-2	8.000	3.04	5.00	2.31	13.60	0.70	0.76	0.76	7.00	5.64	0.22	7800	0.35
KW 06B-2*	9.525	5.72	6.35	3.28	23.50	1.00	1.30	1.30	8.20	10.24	0.56	16900	0.80
KW 08B-2	12.700	7.75	8.51	4.45	30.60	1.40	1.60	1.60	11.80	13.92	1.01	32000	1.35
KW 10B-2	15.875	9.65	10.16	5.08	36.20	1.40	1.70	1.70	14.70	16.59	1.34	44500	1.89
KW 12B-2	19.050	11.68	12.07	5.72	42.10	1.40	1.85	1.85	16.10	19.46	1.79	57800	2.45
KW 16B-2	25.400	17.02	15.88	8.28	67.00	2.10	4.00	3.00	20.90	31.88	4.21	106000	5.60
KW 20B-2	31.750	19.58	19.05	10.19	77.20	3.50	4.50	3.50	26.30	36.45	5.91	170000	7.97
KW 24B-2	38.100	25.40	25.40	14.63	101.60	4.70	6.00	4.80	33.30	48.36	11.09	280000	14.10
KW 28B-2	44.450	30.99	27.94	15.90	124.60	5.30	7.50	6.00	36.80	59.56	14.79	360000	18.76
KW 32B-2	50.800	30.99	29.21	17.81	123.80	5.80	7.00	6.40	42.20	58.55	16.21	450000	20.00
KW 40B-2	63.500	38.10	39.37	22.85	154.50	7.00	8.50	8.00	52.80	72.30	25.50	630000	33.00
KW 48B-2	76.200	45.70	48.20	29.20	190.00	8.00	12.00	10.00	64.00	91.21	41.23	1000000	54.00
KW 56B-2HFS	88.900	53.34	54.00	34.30	221.50	11.50	14.00	12.00	78.00	106.60	55.80	1600000	75.00
KW 64B-2HFS	101.600	60.96	63.50	39.40	250.00	10.00	15.00	14.00	93.30	119.89	72.50	2100000	100.00
KW 72B-2HFS	114.300	68.58	72.39	44.50	282.80	10.70	18.00	15.00	103.63	136.27	92.40	2700000	129.00

\* straight link plate

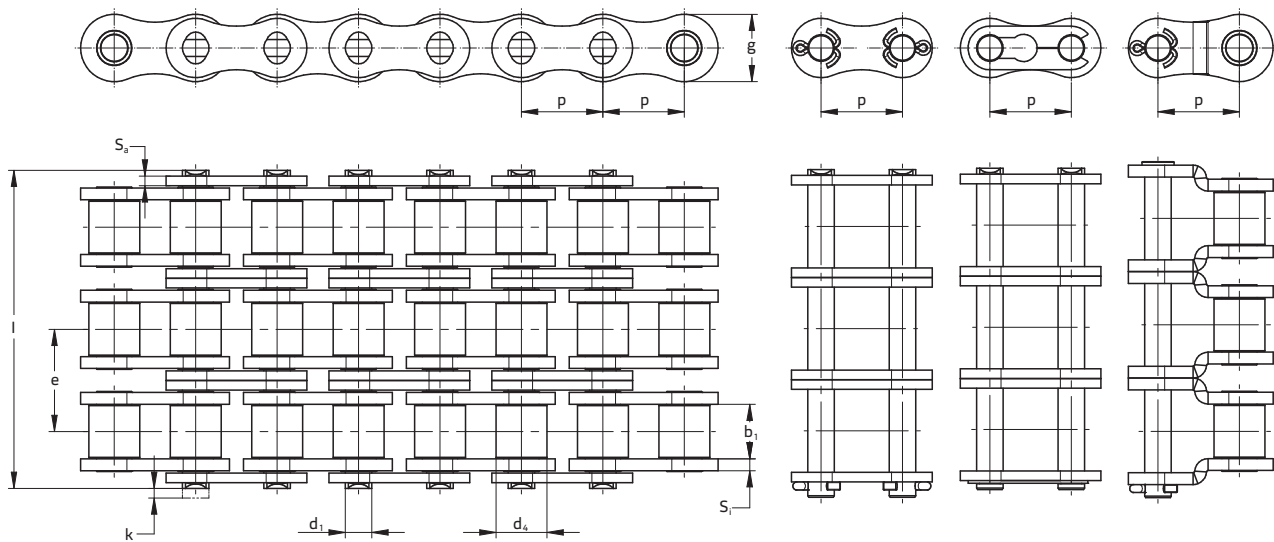
» The indicated breaking loads are those stipulated in ISO 606. We will be happy to provide you with the actual higher breaking loads upon request.

» We can also produce larger roller chains than 80B upon request.

# DIN 8187 / ISO 606-compliant KW roller chains

## KW triplex

Drawings / product data (European standard)



### KettenWulf wear-resistant roller chains

KW triplex, sizes according to European standards

ISO 606 / DIN 8187

Designation	Pitch [mm]	Min. inner width [mm]	Max. protection roller Ø [mm]	Max. pin Ø [mm]	Max. pin length [mm]	Max. overhang connecting pin [mm]	Inner plate thickness [mm]	Outer plate thickness [mm]	Plate height [mm]	Transverse pitch [mm]	Bearing area [cm <sup>2</sup> ]	Min. breaking load [N]	Weight [kg/m]
Chain type	p	b <sub>1</sub>	d <sub>4</sub>	d <sub>1</sub>	l	k	S <sub>1</sub>	S <sub>2</sub>	g	e	f	F <sub>B</sub>	≈ q
KW 06B-3*	9.525	5.72	6.35	3.28	33.10	2.30	1.30	1.30	8.20	10.24	0.84	24900	1.12
KW 08B-3	12.700	7.75	8.51	4.45	44.90	1.10	1.60	1.60	11.80	13.92	1.51	44500	2.05
KW 10B-3	15.875	9.65	10.16	5.08	52.80	1.40	1.70	1.70	14.70	16.59	2.02	66700	2.64
KW 12B-3	19.050	11.68	12.07	5.72	61.50	1.50	1.85	1.85	16.10	19.46	2.68	86700	3.67
KW 16B-3	25.400	17.02	15.88	8.28	99.40	3.30	4.20	3.10	21.00	31.88	6.31	166000	8.00
KW 20B-3	31.750	19.58	19.05	10.19	113.50	3.50	4.50	3.50	26.30	36.45	8.87	250000	11.24
KW 24B-3	38.100	25.40	25.40	14.63	150.00	4.70	6.00	4.80	33.25	48.36	16.63	425000	21.00
KW 28B-3	44.450	30.99	27.94	15.90	184.20	5.30	7.50	6.00	36.80	59.56	22.18	530000	28.56
KW 32B-3	50.800	30.99	29.21	17.81	182.40	5.80	7.00	6.40	42.00	58.55	24.31	670000	30.00
KW 40B-3	63.500	38.10	39.37	22.85	228.50	5.30	8.50	8.00	52.80	72.30	38.25	950000	50.00
KW 48B-3	76.200	45.70	48.20	29.20	281.00	8.00	12.00	10.00	64.00	91.21	61.84	1500000	80.00
KW 56B-3HFS	88.900	53.34	54.00	34.30	330.00	12.00	14.00	12.00	78.00	106.60	83.71	2310000	111.50
KW 64B-3HFS	101.600	60.96	63.50	39.40	370.00	10.00	15.00	14.00	90.17	119.89	108.74	3050000	150.00
KW 72B-3HFS	114.300	68.58	72.39	44.50	420.00	14.00	18.00	15.00	103.63	136.27	135.57	3930000	194.00

\* straight link plate

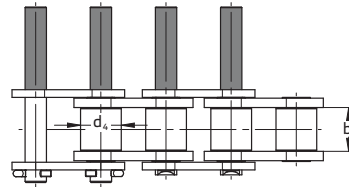
» The indicated breaking loads are those stipulated in ISO 606. We will be happy to provide you with the actual higher breaking loads upon request.

» We can also produce larger roller chains than 80B upon request.

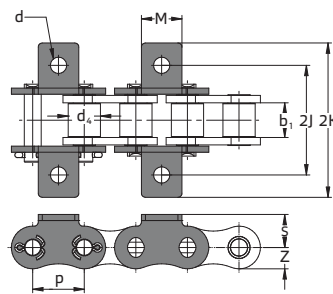
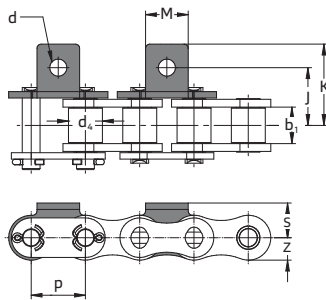
# Attachments for roller chains

Our product portfolio includes a variety of attachments:

- » bent plates or straight attachment plate
- » one or two attachment
- » extended pins

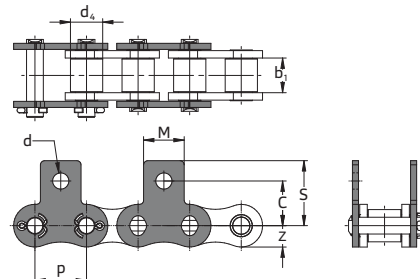
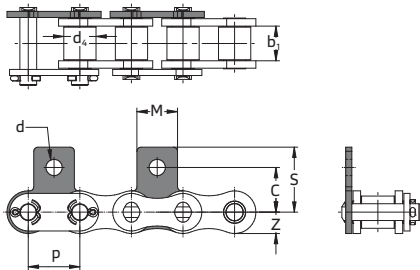


extended pins (available upon request)



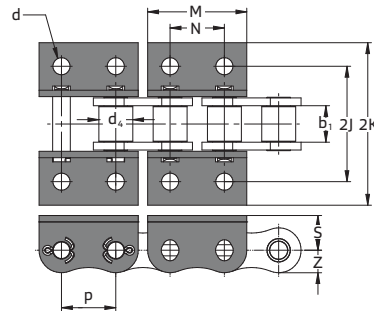
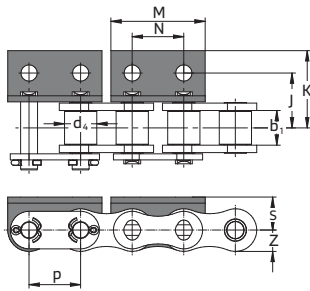
bent plates with angle on one side A-1

bent plates with angle on both sides K-1



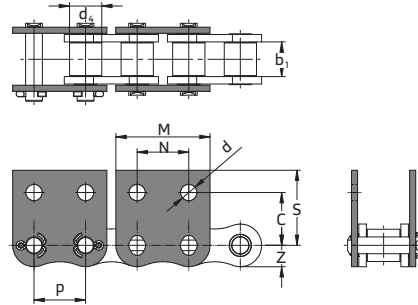
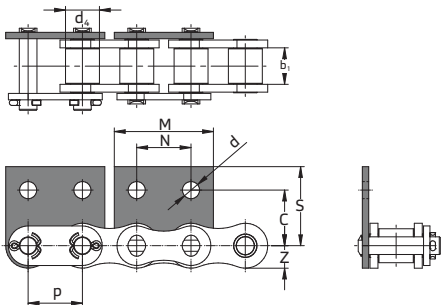
extended link plate on one side SA-1

extended link plate on both sides SK-1



bent plates with angle on one side WA-2

bent plates with angle on both sides WK-2



extended link plate on one side WSA-2

extended link plate on both sides WSK-2

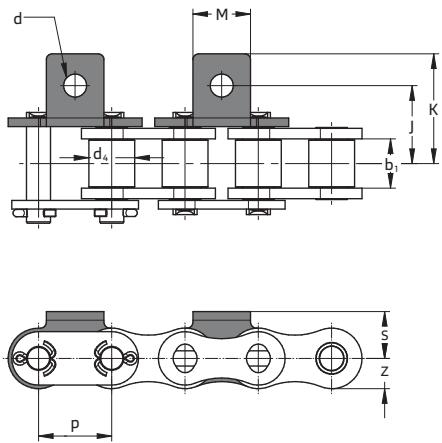
» Our attachments can be supplied as separate components or mounted to the chain. Other designs and attachments for double linked roller chains are available upon request.



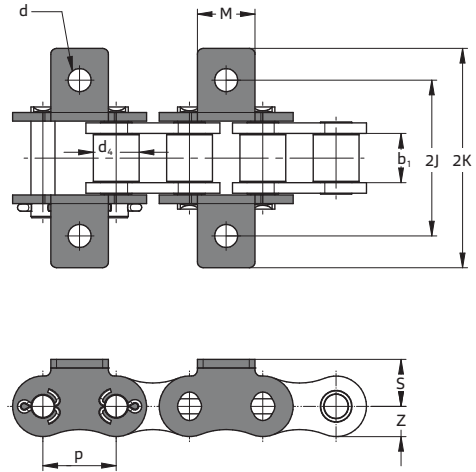
# Attachments A-1 / K-1

## bent plates with angle on one side / on both sides A-1 / K-1

Drawings / product data



bent plates with angle on one side A-1



bent plates with angle on both sides K-1

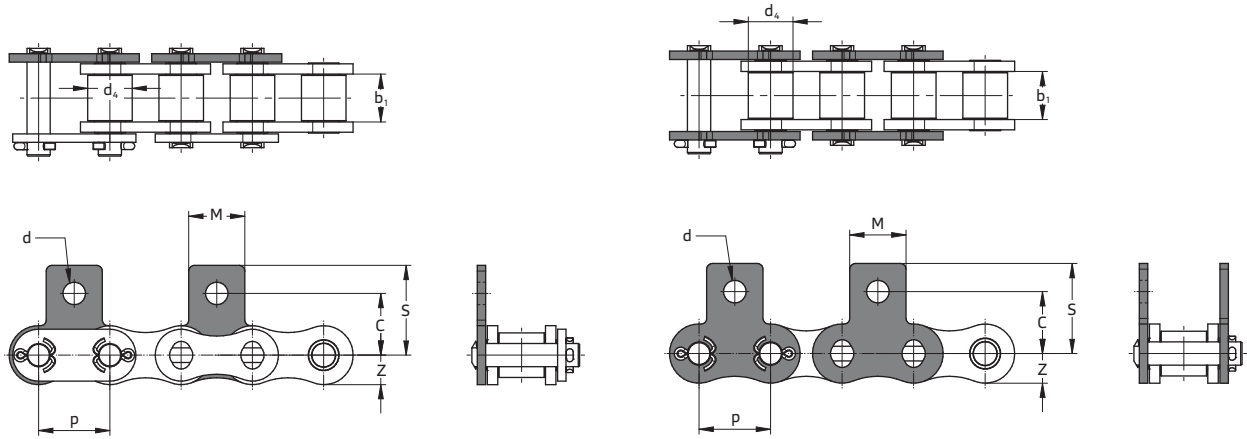
KW A-1 / K-1

Designation	Pitch [mm]	Min. inner width [mm]	Max. roller Ø [mm]	Min. breaking load [N]	Attachment	Attachment width [mm]	Attachment thickness [mm]	Fastener hole Ø [mm]	Mid of chain - mid of fastener hole [mm]	Mid of chain - outer edge attachment [mm]	Mid of chain - bottom edge attachment [mm]	Mid of chain - outer edge attachment [mm]
Chain type	p	b <sub>1</sub>	d <sub>4</sub>	F <sub>B</sub>		M	T	d	J	K	Z	S
KW 06B	9.525	5.72	6.35	8900	A-1 K-1	8.00	1.25	3.50	9.50	13.50	4.10	6.50
KW 08B	12.700	7.75	8.51	16000	A-1 K-1	12.50	1.50	4.50	13.10	19.00	5.90	10.00
KW 10B	15.875	9.65	10.16	22200	A-1 K-1	15.00	1.70	5.50	16.70	27.00	7.35	10.00
KW 12B	19.050	11.68	12.07	28900	A-1 K-1	18.50	1.80	6.60	18.60	29.00	8.05	11.00
KW 16B	25.400	17.02	15.88	60000	A-1 K-1	25.00	3.00	9.00	28.90	41.80	10.50	18.00
KW 20B	31.750	19.56	19.05	95000	A-1 K-1	35.00	3.75	9.00	33.40	49.00	13.20	18.00
KW 24B	38.100	25.40	25.40	160000	A-1 K-1	38.00	5.00	11.00	44.00	64.00	16.70	25.00

## Attachments SA-1 / SK-1

### extended link plate on one side / on both sides SA-1/SK-1

Drawings / product data



extended link plate on one side SA-1

extended link plate on both sides SK-1

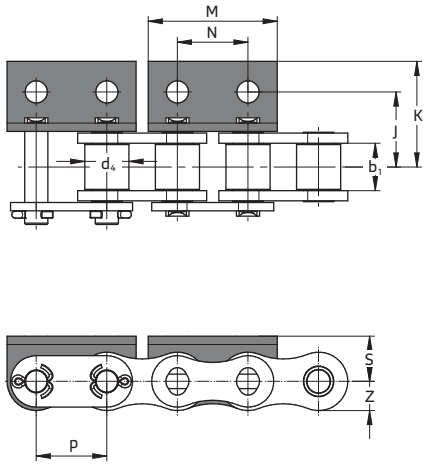
#### KW SA-1 / SK-1

Designation	Pitch [mm]	Min. inner width [mm]	Max. roller Ø [mm]	Min. breaking load [N]	Attachment	Attachment width [mm]	Attachment thickness [mm]	Fastening hole Ø [mm]	Mid of chain - mid of fastening hole [mm]	Mid of chain - bottom edge attachment [mm]	Mid of chain - outer edge attachment [mm]
Chain type	p	b <sub>i</sub>	d <sub>s</sub>	F <sub>B</sub>		M	T	d	c	Z	S
KW 06B	9.525	5.72	6.35	8900	SA-1	8.00	1.25	3.50	9.00	4.10	13.80
					SK-1						
KW 08B	12.700	7.75	8.51	16000	SA-1	12.50	1.50	4.50	14.70	5.90	20.30
					SK-1						
KW 10B	15.875	9.65	10.16	22200	SA-1	15.00	1.70	5.50	17.20	7.35	26.70
					SK-1						
KW 12B	19.050	11.68	12.07	28900	SA-1	18.50	1.80	6.60	18.70	8.05	29.00
					SK-1						
KW 16B	25.400	17.02	15.88	60000	SA-1	25.00	3.00	9.00	28.60	10.50	41.50
					SK-1						
KW 20B	31.750	19.56	19.05	95000	SA-1	35.00	3.75	9.00	30.50	13.20	46.00
					SK-1						
KW 24B	38.100	25.40	25.40	160000	SA-1	38.00	5.00	11.00	41.00	16.70	60.00
					SK-1						

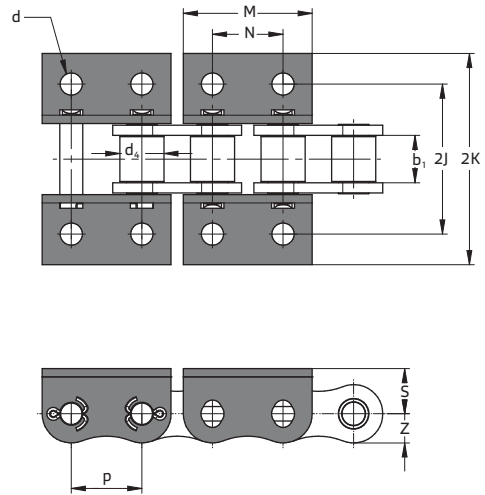
# Attachments WA-2 / WK-2

## bent plates with angle on one side / on both sides WA-2 / WK-2

Drawings / product data



bent plates with angle on one side WA-2



bent plates with angle on both sides WK-2

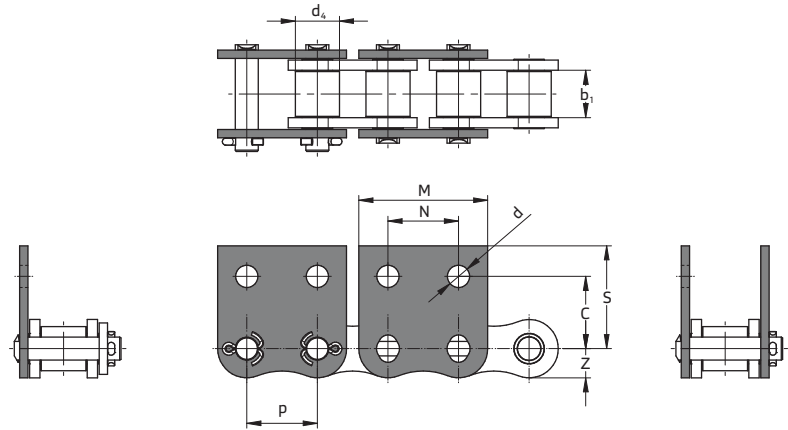
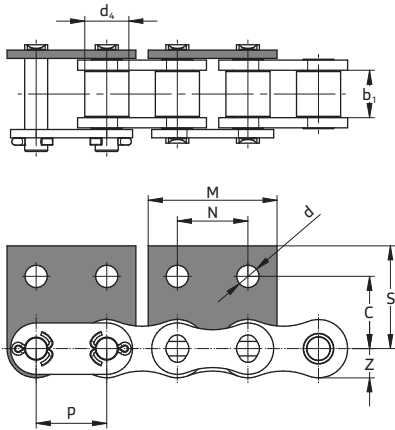
KW WA-2 / WK-2

Designation	Pitch [mm]	Min. inner width [mm]	Max. roller Ø [mm]	Min. breaking load [N]	Attachment	Attachment width [mm]	Attachment thickness [mm]	Fastening hole Ø [mm]	Mid of chain - mid of fastening hole [mm]	Mid of chain - outer edge attachment [mm]	Mid of chain - bottom edge attachment [mm]	Mid of chain - outer edge attachment [mm]	Fastening hole pitch [mm]
Chain type	p	b <sub>1</sub>	d <sub>4</sub>	F <sub>B</sub>		M	T	d	J	k	Z	S	N
KW 06B	9.525	5.72	6.35	8900	WA-2	18.20	1.25	3.20	9.80	13.20	4.10	5.70	9.50
					WK-2								
KW 08B	12.700	7.75	8.51	16000	WA-2	23.20	1.50	4.50	13.10	19.00	5.90	10.00	12.70
					WK-2								
KW 10B	15.875	9.65	10.16	22200	WA-2	28.50	1.70	5.50	16.70	27.00	7.35	10.00	15.90
					WK-2								
KW 12B	19.050	11.68	12.07	28900	WA-2	33.60	1.80	6.60	18.60	29.00	8.05	11.00	19.10
					WK-2								
KW 16B	25.400	17.02	15.88	60000	WA-2	46.50	3.00	9.00	28.90	41.80	10.50	18.00	25.40
					WK-2								
KW 20B	31.750	19.56	19.05	95000	WA-2	55.80	3.75	9.00	33.40	49.00	13.20	18.00	31.80
					WK-2								
KW 24B	38.100	25.40	25.40	160000	WA-2	71.10	5.00	11.00	44.00	64.00	16.70	25.00	38.10
					WK-2								

# Attachments WSA-2 / WSK-2

## extended link plate on one side / on both sides WSA-2 / WSK-2

Drawings / product data



extended link plate on one side WSA-2

extended link plate on both sides WSK-2

### KW WSA-2 / WSK-2

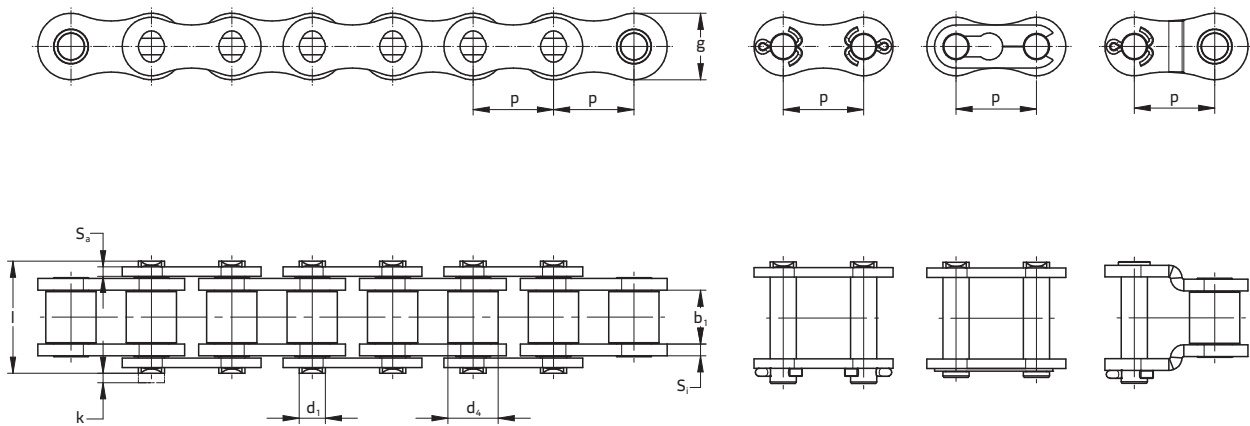
Designation	Pitch [mm]	Min. inner width [mm]	Max. roller Ø [mm]	Min. breaking load [N]	Attachment	Attachment width [mm]	Attachment thickness [mm]	Fastening hole Ø [mm]	Mid of chain - mid of fastening hole [mm]	Mid of chain - outer edge attachment [mm]	Mid of chain - bottom edge attachment [mm]	Fastening hole pitch [mm]
Chain type	p	b₁	d₄	F <sub>b</sub>		M	T	d	C	S	Z	N
KW 06B	9.525	5.72	6.35	8900	WSA-2	18.20	1.25	3.20	9.20	12.60	4.10	9.50
					WSK-2							
KW 08B	12.700	7.75	8.51	16000	WSA-2	23.20	1.50	4.50	14.70	20.30	5.90	12.70
					WSK-2							
KW 10B	15.875	9.65	10.16	22200	WSA-2	28.50	1.70	5.50	17.20	26.70	7.35	15.90
					WSK-2							
KW 12B	19.050	11.68	12.07	28900	WSA-2	33.60	1.80	6.60	18.70	29.00	8.05	19.10
					WSK-2							
KW 16B	25.400	17.02	15.88	60000	WSA-2	46.50	3.00	9.00	28.60	41.50	10.50	25.40
					WSK-2							
KW 20B	31.750	19.56	19.05	95000	WSA-2	55.80	3.75	9.00	30.50	46.00	13.20	31.80
					WSK-2							
KW 24B	38.100	25.40	25.40	160000	WSA-2	71.10	5.00	11.00	41.00	60.00	16.70	38.10
					WSK-2							



# DIN 8188 / ISO 606-compliant KW roller chains

## KW simplex

Drawings / product data (American standard)



### KettenWulf wear-resistant roller chain

KW simplex, sizes according to American standard

ISO 606 / DIN 8188

Designation	Pitch [mm]	Min. inner width [mm]	Max. protection roller $\varnothing$ [mm]	Max. pin $\varnothing$ [mm]	Max. pin length [mm]	Max. overhang connecting pin [mm]	Inner plate thickness [mm]	Outer plate thickness [mm]	Plate height [mm]	Bearing area [cm <sup>2</sup> ]	Min. breaking load [N]	Weight [kg/m]
Chain type	p	b <sub>1</sub>	d <sub>4</sub>	d <sub>1</sub>	l	k	S <sub>1</sub>	S <sub>2</sub>	g	f	F <sub>B</sub>	≈q
KW 25	6.350	3.18	3.30	2.31	7.80	0.60	0.76	0.76	5.90	0.11	3500	0.15
KW 35	9.525	4.68	5.08	3.58	12.15	0.95	1.30	1.30	9.00	0.27	7900	0.36
KW 40	12.700	7.85	7.92	3.96	16.60	1.15	1.50	1.50	12.00	0.43	13800	0.64
KW 41	12.700	6.25	7.77	3.58	13.75	1.65	1.30	1.30	9.90	0.32	6700	0.48
KW 50**	15.875	9.40	10.14	5.08	20.40	2.10	2.00	2.00	14.60	0.69	21800	1.04
KW 60**	19.050	12.57	11.91	5.94	25.30	3.30	2.40	2.40	17.50	1.05	31800	1.53
KW 80**	25.400	15.75	15.88	7.92	32.60	2.30	3.20	3.20	24.00	1.77	55600	2.56
KW 100	31.750	18.90	19.05	9.53	39.70	3.70	4.00	4.00	30.10	2.58	87000	4.10
KW 120	38.100	25.22	22.23	11.11	50.45	3.05	4.80	4.80	35.00	3.89	125000	6.00
KW 140	44.450	25.30	25.40	12.70	54.50	4.20	5.60	5.60	42.00	4.64	169000	7.74
KW 160	50.800	31.55	28.58	14.27	64.50	4.20	6.40	6.40	41.50	6.36	223000	10.25
KW 180	57.150	35.48	35.70	17.46	72.80	5.80	7.20	7.20	53.60	8.75	280200	13.40
KW 200	63.500	54.94	39.68	19.84	79.50	6.00	8.00	8.00	60.00	10.73	347000	17.00
KW 240	76.200	47.63	47.63	23.80	96.50	7.50	9.50	9.50	72.39	15.86	500000	25.00

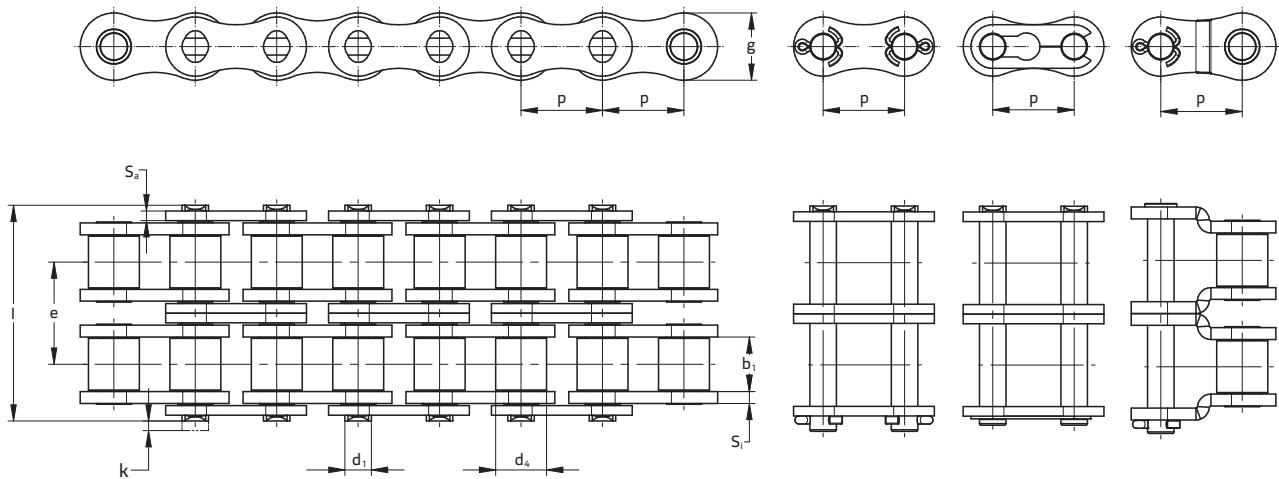
\*\* also available on reel from stock

» The indicated breaking loads are those stipulated in ISO 606. We will be happy to provide you with the actual higher breaking loads upon request.

# DIN 8188 / ISO 606-compliant KW roller chains

## KW duplex

Drawings / product data (American standard)



### KettenWulf wear-resistant roller chains

KW duplex, sizes according to American standard

ISO 606 / DIN 8188

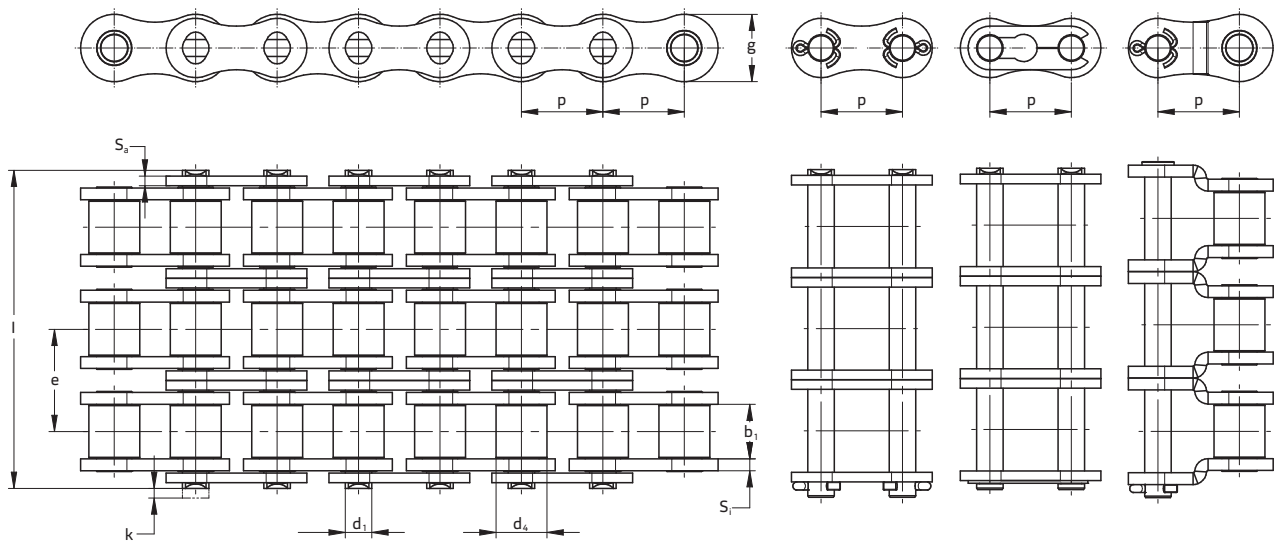
Designation	Pitch [mm]	Min. inner width [mm]	Max. protection roller $\varnothing$ [mm]	Max. pin $\varnothing$ [mm]	Max. pin length [mm]	Max. overhang connecting pin [mm]	Inner plate thickness [mm]	Outer plate thickness [mm]	Plate height [mm]	Transverse pitch [mm]	Bearing area [cm <sup>2</sup> ]	Min. breaking load [N]	Weight [kg/m]
Chain type	p	b <sub>1</sub>	d <sub>e</sub>	d <sub>1</sub>	l	k	S <sub>1</sub>	S <sub>2</sub>	g	e	f	F <sub>B</sub>	≈q
KW 35-2	9.525	4.68	5.08	3.58	22.50	0.90	1.30	1.30	9.00	10.13	0.53	15800	0.71
KW 40-2	12.700	7.85	7.92	3.96	31.10	1.15	1.50	1.50	12.00	14.38	0.87	27600	1.36
KW 50-2	15.875	9.40	10.14	5.08	38.50	2.10	2.00	2.00	14.60	18.11	1.38	43600	2.05
KW 60-2	19.050	12.57	11.91	5.94	48.40	1.90	2.40	2.40	18.00	22.78	2.10	63600	3.03
KW 80-2	25.400	15.75	15.80	7.92	61.90	2.30	3.20	3.20	24.00	29.29	3.54	111200	5.09
KW 100-2	31.750	18.90	19.05	9.53	75.80	3.30	4.00	4.00	30.10	35.76	5.16	174000	8.14
KW 120-2	38.100	25.22	22.23	11.11	95.70	3.10	4.80	4.80	35.00	45.44	7.78	250000	11.86
KW 140-2	44.450	25.30	25.40	12.70	103.10	4.20	5.60	5.60	42.00	48.90	9.40	340000	15.34
KW 160-2	50.800	31.55	28.58	14.27	122.90	4.30	6.40	6.40	48.00	58.50	12.72	446000	20.35
KW 180-2	57.150	35.48	35.71	17.46	138.60	5.80	7.20	7.20	53.60	65.84	17.50	562000	27.60
KW 200-2	63.500	54.94	39.68	19.84	151.00	5.90	8.00	8.00	60.00	71.60	21.50	693900	33.41
KW 240-2	76.200	47.63	47.63	23.80	185.00	9.00	9.50	9.50	71.00	78.83	31.70	1000000	46.00

» The indicated breaking loads are those stipulated in ISO 606. We will be happy to provide you with the actual higher breaking loads upon request.

# DIN 8188 / ISO 606-compliant KW roller chains

## KW triplex

Drawings / product data (American standard)



### KettenWulf wear-resistant roller chains

KW triplex, sizes according to American standard

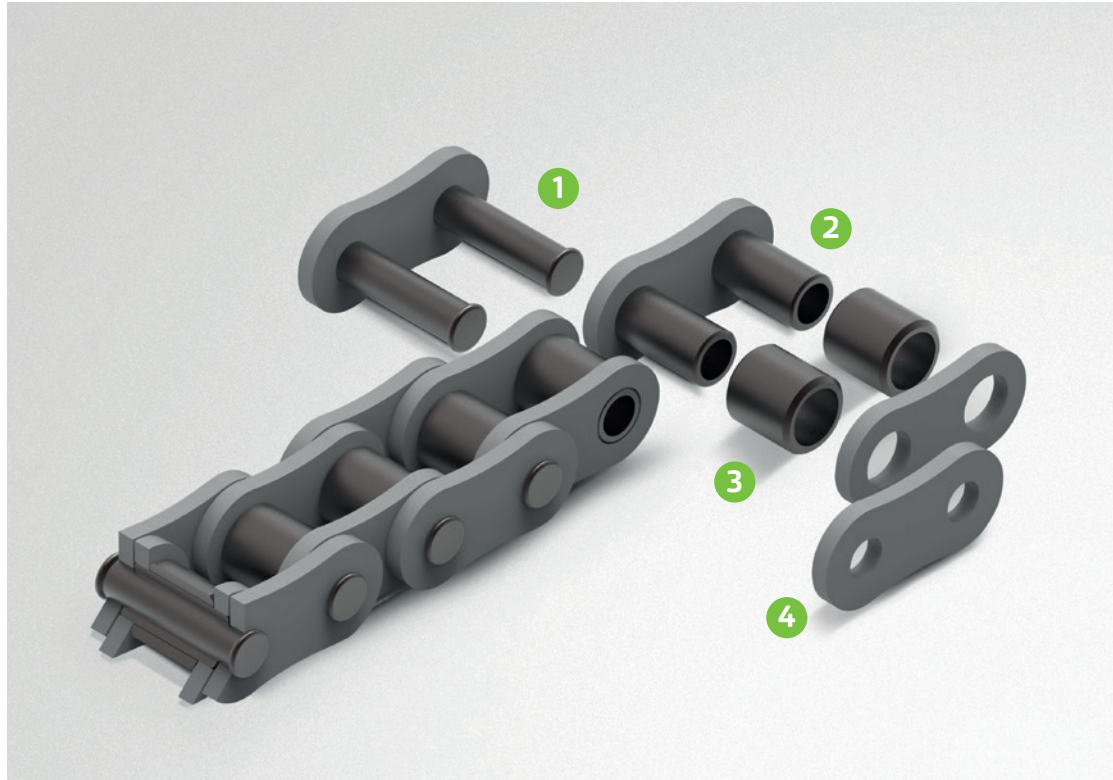
ISO 606 / DIN 8188

Designation	Pitch [mm]	Min. inner width [mm]	Max. protection roller $\varnothing$ [mm]	Max. pin $\varnothing$ [mm]	Max. pin length [mm]	Max. overhang connecting pin [mm]	Inner plate thickness [mm]	Outer plate thickness [mm]	Plate height [mm]	Transverse pitch [mm]	Bearing area [cm <sup>2</sup> ]	Min. breaking load [N]	Weight [kg/m]
Chain type	$p$	$b_1$	$d_4$	$d_1$	$l$	$k$	$S_1$	$S_a$	$g$	$e$	$f$	$F_B$	$\approx q$
KW 35-3	9.525	4.68	5.08	3.58	32.60	0.90	1.30	1.30	9.00	10.13	0.80	23400	0.97
KW 40-3	12.700	7.85	7.92	3.96	45.40	1.40	1.50	1.50	12.00	14.38	1.30	41400	1.97
KW 50-3	15.875	9.40	10.14	5.08	56.60	2.10	2.00	2.00	14.60	18.11	2.07	65400	3.08
KW 60-3	19.050	12.57	11.91	5.94	71.50	1.70	2.40	2.40	18.00	22.78	3.13	95400	4.53
KW 80-3	25.400	15.75	15.88	7.92	90.60	3.60	3.00	3.00	23.10	29.29	5.31	166800	7.61
KW 100-3	31.750	18.90	19.05	9.53	111.60	3.40	4.00	4.00	30.10	35.76	7.73	261000	12.17
KW 120-3	38.100	25.30	22.23	11.10	141.00	3.10	4.80	4.80	35.80	45.44	11.66	375000	17.74
KW 140-3	44.450	25.22	25.40	12.70	152.20	4.60	5.60	5.60	42.10	48.87	14.10	507000	22.94
KW 160-3	50.800	31.55	28.58	14.27	181.40	4.20	6.40	6.40	48.00	58.50	19.10	669000	30.45
KW 180-3	57.150	35.48	35.71	17.46	204.40	5.80	7.20	7.20	53.60	65.84	26.40	843000	38.20
KW 200-3	63.500	54.94	39.68	19.84	222.50	5.50	8.00	8.00	60.00	71.60	32.20	1041000	49.87
KW 240-3	76.200	47.63	47.63	23.80	272.00	9.00	9.50	9.50	71.00	87.83	47.60	1500000	72.70

» The indicated breaking loads are those stipulated in ISO 606. We will be happy to provide you with the actual higher breaking loads upon request.

**HS roller chain**

- ① Through hardened pins for a high breaking load
- ② Wear-optimised, seamless, case-hardened bushes
- ③ Seamless, through hardened rollers for high shock and wear resistance
- ④ Ball-blasted link plates, quenched and tempered



## Heavy Series (HS) roller chains

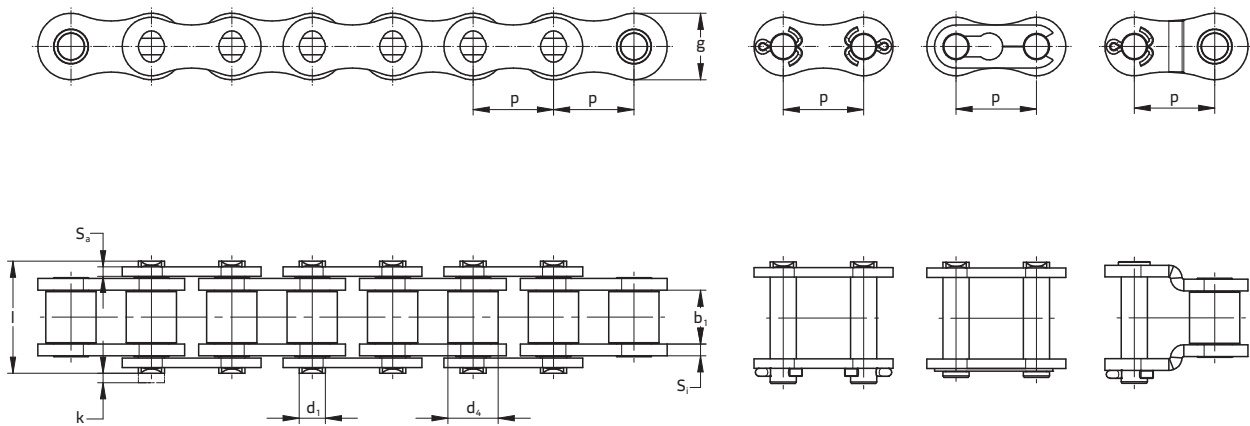
The KettenWulf HS “Heavy Series” roller chain has the same basic characteristics as a standard KW roller chain. Reinforced link plates and highly through hardened pins ensure that the HS roller chains have a higher breaking load as well as an improved resistance to shocks and better fatigue strength properties. HS roller chains are widely used in applications with heavy loads.



# HS roller chain

## KW HS simplex (reinforced)

Drawings / product data (American standard)



### KettenWulf reinforced roller chains

KW HS simplex, sizes according to American standard

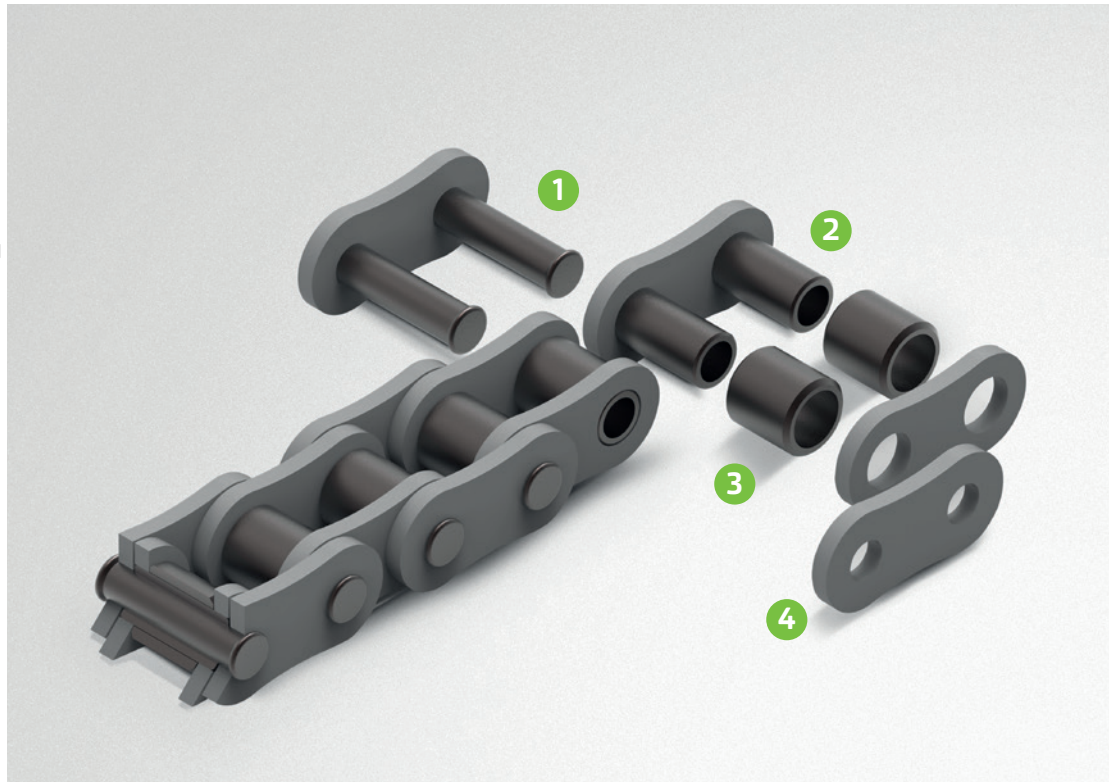
ISO 606 / DIN 8188

Designation	Pitch [mm]	Min. inner width [mm]	Max. protection roller $\varnothing$ [mm]	Max. pin $\varnothing$ [mm]	Max. pin length [mm]	Max. overhang connecting pin [mm]	Inner plate thickness [mm]	Outer plate thickness [mm]	Plate height [mm]	Bearing area [cm <sup>2</sup> ]	Min. breaking load [N]	Weight [kg/m]
Chain type	p	b <sub>1</sub>	d <sub>1</sub>	d <sub>2</sub>	l	k	S <sub>1</sub>	S <sub>2</sub>	g	f	F <sub>a</sub>	≈q
KW 50HS	15.875	9.50	10.14	5.08	22.50	0.70	2.40	2.40	14.60	0.73	34700	1.17
KW 60HS	19.050	12.58	11.91	5.94	28.80	3.20	3.00	3.00	17.50	1.14	49000	1.76
KW 80HS	25.400	15.75	15.88	7.92	36.30	1.70	4.00	4.00	23.10	1.90	87000	3.08
KW 100HS	31.750	18.90	19.05	9.53	43.40	4.80	4.80	4.80	30.10	2.73	133450	4.65
KW 120HS	38.100	25.23	22.23	11.10	53.80	5.20	5.60	5.60	36.00	4.06	182400	6.68
KW 140HS	44.450	25.40	25.40	12.70	56.60	5.90	6.40	6.40	41.00	4.85	170000	8.40
KW 160HS	50.800	31.55	28.85	14.29	69.40	7.90	7.20	7.20	48.26	6.70	223000	10.30
KW 180HS	57.150	35.48	35.71	17.46	77.30	9.10	8.00	8.00	54.30	9.17	281000	14.83
KW 200HS	63.500	37.85	39.68	19.85	87.10	10.20	9.50	9.50	60.33	11.57	347000	19.16
KW 240HS	76.200	47.35	47.63	23.81	11.40	10.50	12.70	12.70	72.39	17.75	500000	30.40

» Also available as duplex and triplex upon request.

### HFS roller chains

- 1 Pins made of special alloyed case-hardened steel, cold-extruded (pins starting from 1 1/2" are made of high alloy heat-treated steel and through hardened), grinded
- 2 Bush – seamless, wear-optimised, cold-extruded bush, case-hardened
- 3 Roller – seamless, cold-extruded Roller, quenched and tempered
- 4 Link plates – high-precision stamped, quenched and tempered ball-blasted, holes calibrated with particularly high percentage contact area. The plate shape is wide waisted



## High Fatigue Strength (HFS) roller chains

The KettenWulf roller chains for high-stress applications.

The chain series HFS "High Fatigue Strength" was developed as a response to the ever-increasing requirements in the field of drive technology. The KettenWulf HFS roller chain has the best quality standard on the market.

Apart from the optimised wear resistance, the main focus is to provide ultimate fatigue strength properties. The high alloy case-hardened steel (up to 1 1/4") of the pins guarantees an outstanding shear strength and a very high flexural strength. The cold drawing process for manufacturing the pins guarantees a high surface hardness while ensuring a high surface quality at the same time.

The wear resistance is further improved by grinding the pins' surface after drawing. Pins that are 1 1/2" or bigger are made of high alloy heat-treated steel. Such pins ensure an even better fatigue strength of the chains and increase the effective breaking loads.

The seamless bushes are characterised by their optimal cylindrical holes which is much higher than that of precision-steel pipe bushes. The chain has a high length precision and a minimum elongation when engaging on the sprocket.

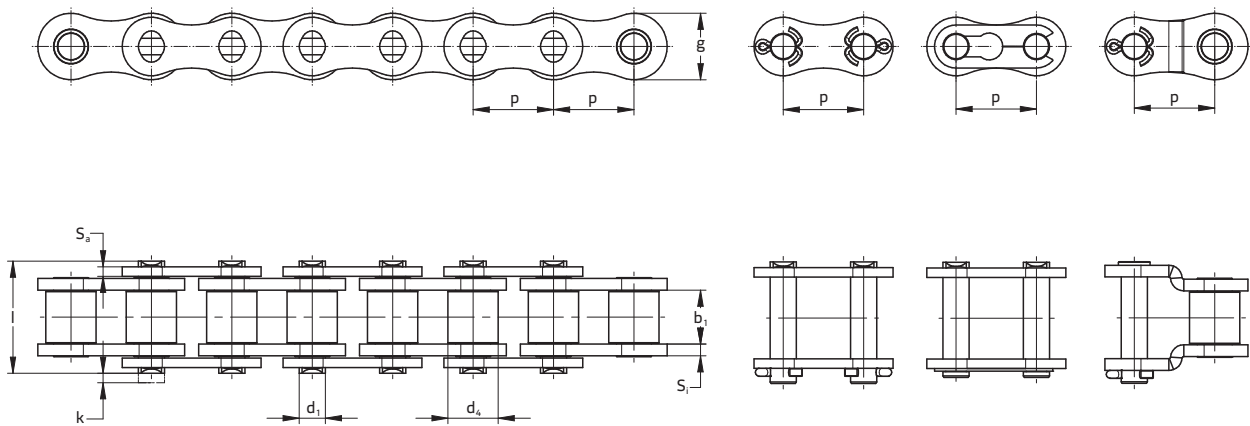
The Cr-alloy steel for the bushes further increases the wear resistance compared to the KettenWulf KW chains.

The high precision of the manufacturing process ensures cylindrical holes in the link plates with the highest possible proportion of clear-cut surface. Such a clear-cut surface is required to ensure high press fit. Combined with the outstanding properties of the Cr-alloyed heat-treated steel material this makes KettenWulf HFS roller chains more durable and resistant to fatigue. The seamless and tempered roller ensures a high level of shock and wear resistance.

# DIN 8187 / ISO 606-compliant HFS roller chains

## KW HFS simplex

Drawings / product data (European standard)



KettenWulf roller chains for high-stress applications

KW HFS simplex, sizes according to European standard

ISO 606 / DIN 8187

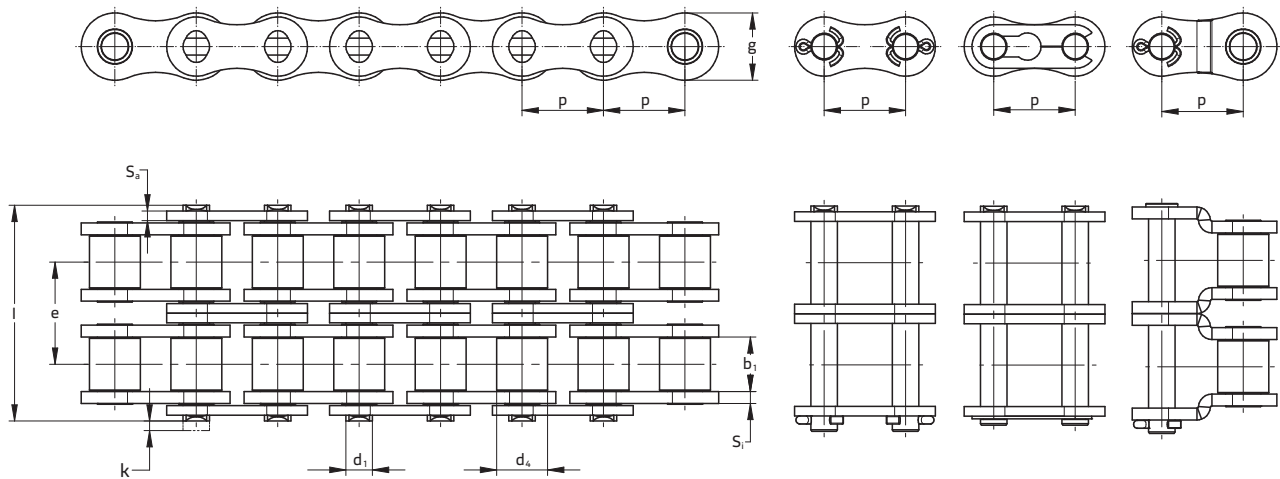
Designation	Pitch [mm]	Min. inner width [mm]	Max. protection roller $\varnothing$ [mm]	Max. pin $\varnothing$ [mm]	Max. pin length [mm]	Max. overhang connecting pin [mm]	Inner plate thickness [mm]	Outer plate thickness [mm]	Plate height [mm]	Bearing area [cm <sup>2</sup> ]	Min. breaking load [N]	Weight [kg/m]
Chain type	p	b <sub>1</sub>	d <sub>2</sub>	d <sub>1</sub>	l	k	S <sub>1</sub>	S <sub>2</sub>	g	f	F <sub>0</sub>	≈ q
KW 08BHFS	12.700	7.75	8.51	4.45	17.00	1.60	1.50	1.50	11.80	0.50	17800	0.75
KW 10BHFS	15.875	9.65	10.16	5.08	19.60	2.50	1.70	1.70	14.70	0.67	24400	0.98
KW 12BHFS	19.050	11.68	12.07	5.72	22.70	3.30	1.85	1.85	16.10	0.89	28900	1.26
KW 16BHFS	25.400	17.02	15.88	8.28	36.10	3.10	4.00	3.00	21.00	2.10	72500	2.83
KW 20BHFS	31.750	19.56	19.05	10.19	43.20	4.40	4.50	3.50	26.40	2.96	105000	3.94
KW 24BHFS	38.100	25.40	25.40	14.63	53.40	6.00	6.00	4.80	33.40	5.54	175000	7.21
KW 28BHFS	44.450	30.99	27.94	15.90	65.10	5.90	7.50	6.00	37.00	7.39	235000	9.58
KW 32BHFS	50.800	30.99	29.21	17.81	67.40	4.60	7.00	6.00	42.20	8.10	265000	9.97
KW 40BHFS	63.500	38.10	39.37	22.89	81.50	7.00	8.50	8.00	52.90	12.75	400000	17.00
KW 48BHFS	76.200	45.72	48.20	29.20	99.10	6.90	12.00	10.00	64.00	20.61	600000	27.00
KW 56BHFS	88.900	53.34	54.00	34.30	113.00	12.00	14.00	12.00	78.00	27.90	850000	38.00
KW 64BHFS	101.600	60.96	63.50	39.40	129.00	19.00	15.00	14.00	93.30	36.25	1120000	49.50
KW 72BHFS	114.300	68.58	72.39	44.50	147.00	14.00	18.00	15.00	103.63	46.19	1400000	64.50

» We can also produce larger roller chains than 80B upon request.

# DIN 8187 / ISO 606-compliant HFS roller chains

## KW HFS duplex

Drawings / product data (European standard)



KettenWulf roller chains for high-stress applications

KW HFS duplex, sizes according to European standard

ISO 606 / DIN 8187

Designation	Pitch [mm]	Min. inner width [mm]	Max. protection roller Ø [mm]	Max. pin Ø [mm]	Max. pin length [mm]	Max. overhang connecting pin [mm]	Inner plate thickness [mm]	Outer plate thickness [mm]	Plate height [mm]	Transverse pitch [mm]	Bearing area [cm <sup>2</sup> ]	Min. breaking load [N]	Weight [kg/m]
Chain type	p	b <sub>1</sub>	d <sub>4</sub>	d <sub>1</sub>	l	k	S <sub>1</sub>	S <sub>2</sub>	g	e	f	F <sub>B</sub>	≈q
KW 08B-2HFS	12.700	7.75	8.51	4.45	31.00	1.60	1.50	1.50	11.80	13.92	1.01	35600	1.45
KW 10B-2HFS	15.875	9.65	10.16	5.08	36.20	2.70	1.70	1.70	14.70	16.59	1.34	48800	1.93
KW 12B-2HFS	19.050	11.68	12.07	5.72	42.20	3.00	1.85	1.85	16.10	19.46	1.79	57800	2.49
KW 16B-2HFS	25.400	17.02	15.88	8.28	68.00	3.40	4.00	3.00	21.00	31.88	4.21	145000	5.28
KW 20B-2HFS	31.750	19.56	19.05	10.19	79.00	5.10	4.50	3.50	26.40	36.45	5.91	210000	7.78
KW 24B-2HFS	38.100	25.40	25.40	14.63	101.00	7.00	6.00	4.80	33.40	48.36	11.08	350000	14.31
KW 28B-2HFS	44.450	30.99	27.94	15.90	124.00	6.30	7.50	6.00	37.00	59.56	14.79	470000	19.00
KW 32B-2HFS	50.800	30.99	29.21	17.81	126.00	4.70	7.00	6.00	42.20	58.55	16.21	530000	19.59
KW 40B-2HFS	63.500	38.10	39.37	22.85	153.00	7.40	8.50	8.00	52.96	72.29	25.50	800000	33.00
KW 48B-2HFS	76.200	45.72	48.20	29.20	190.40	7.60	12.00	10.00	64.00	91.21	41.23	1200000	54.00
KW 56B-2HFS	88.900	53.34	54.00	34.30	221.50	11.50	14.00	12.00	78.00	106.60	55.80	1600000	75.00
KW 64B-2HFS	101.600	60.96	63.50	39.40	250.00	10.00	15.00	14.00	93.30	119.89	72.50	2100000	100.00
KW 72B-2HFS	114.300	68.58	72.39	44.50	282.80	10.70	18.00	15.00	103.63	136.27	92.40	2700000	129.00

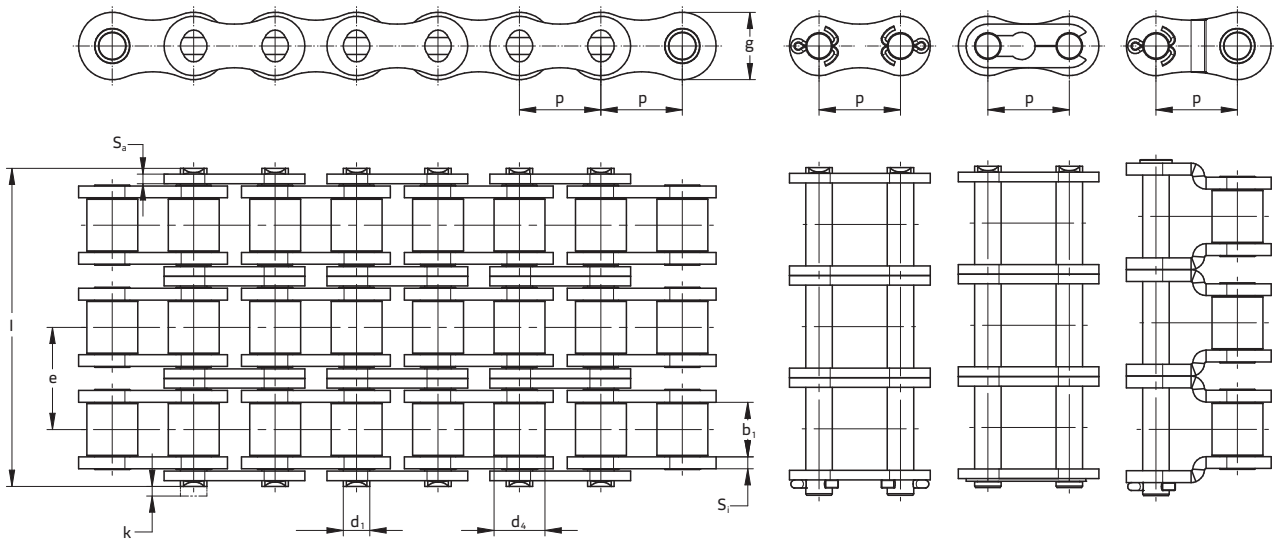
» We can also produce larger roller chains than 80B upon request.



# DIN 8187 / ISO 606-compliant HFS roller chains

## KW HFS triplex

Drawings / product data (European standard)



### KettenWulf roller chains for high-stress applications

KW HFS triplex, sizes according to European standard

ISO 606 / DIN 8187

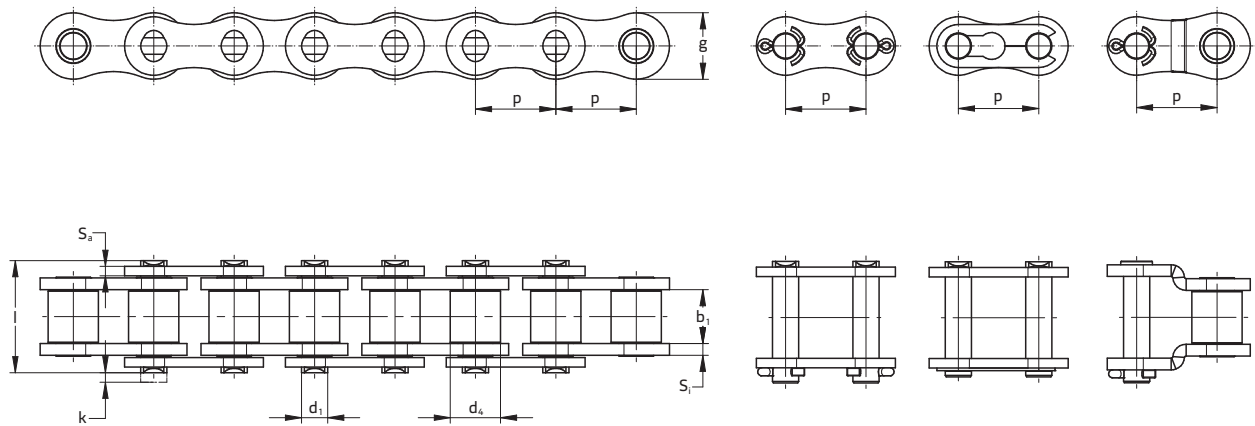
Designation	Pitch [mm]	Min. inner width [mm]	Max. protection roller $\varnothing$ [mm]	Max. pin $\varnothing$ [mm]	Max. pin length [mm]	Max. overhang connecting pin [mm]	Inner plate thickness [mm]	Outer plate thickness [mm]	Plate height [mm]	Transverse pitch [mm]	Bearing area [cm <sup>2</sup> ]	Min. breaking load [N]	Weight [kg/m]
Chain type	p	b <sub>1</sub>	d <sub>s</sub>	d <sub>1</sub>	l	k	S <sub>1</sub>	S <sub>a</sub>	g	e	f	F <sub>0</sub>	≈q
KW 08B-3HFS	12.700	7.75	8.51	4.45	44.90	1.70	1.50	1.50	11.80	13.92	1.51	53400	2.15
KW 10B-3HFS	15.875	9.65	10.16	5.08	52.80	2.50	1.70	1.70	14.70	16.59	2.02	73200	2.89
KW 12B-3HFS	19.050	11.68	12.07	5.72	61.70	3.20	1.85	1.85	16.10	19.46	2.68	86700	3.72
KW 16B-3HFS	25.400	17.02	15.88	8.28	99.90	3.60	4.00	3.00	21.00	31.88	6.31	217500	7.88
KW 20B-3HFS	31.750	19.56	19.05	10.19	116.00	4.60	4.50	3.50	26.40	36.45	8.87	315000	11.66
KW 24B-3HFS	38.100	25.40	25.40	14.63	150.00	5.80	6.00	4.80	33.40	48.36	16.63	525000	21.10
KW 28B-3HFS	44.450	30.99	27.94	15.90	184.00	5.80	7.50	6.00	37.00	59.56	22.18	705000	28.34
KW 32B-3HFS	50.800	30.99	29.21	17.81	184.00	4.80	7.00	6.00	42.20	58.55	24.31	795000	29.30
KW 40B-3HFS	63.500	38.10	39.37	22.89	226.00	7.00	8.50	8.00	52.90	72.29	38.25	1200000	50.00
KW 48B-3HFS	76.200	45.72	48.20	29.20	281.00	8.00	12.00	10.00	64.00	91.21	61.84	1800000	80.00
KW 56B-3HFS	88.900	53.34	54.00	34.30	330.00	12.00	14.00	12.00	78.00	106.60	83.71	2310000	111.50
KW 64B-3HFS	101.600	60.96	63.50	39.40	370.00	10.00	15.00	14.00	90.17	119.89	108.74	3050000	150.00
KW 72B-3HFS	114.300	68.58	72.39	44.50	420.00	14.00	18.00	15.00	103.63	136.27	135.57	3930000	194.00

» We can also produce larger roller chains than 80B upon request.

# DIN 8188 / ISO 606-compliant HFS roller chains

## KW HFS simplex

Drawings / product data (American standard)



### KettenWulf roller chains for high-stress applications

KW HFS simplex, sizes according to American standard

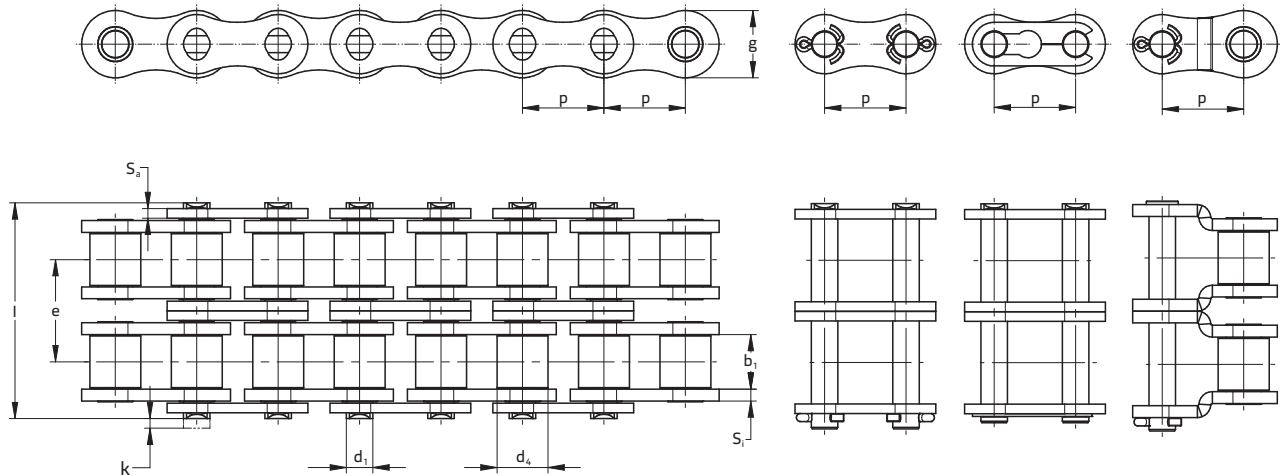
ISO 606 / DIN 8188

Designation	Pitch [mm]	Min. inner width [mm]	Max. protection roller $\varnothing$ [mm]	Max. pin $\varnothing$ [mm]	Max. pin length [mm]	Max. overhang connecting pin [mm]	Inner plate thickness [mm]	Outer plate thickness [mm]	Plate height [mm]	Bearing area [cm <sup>2</sup> ]	Min. breaking load [N]	Weight [kg/m]
Chain type	p	b <sub>1</sub>	d <sub>e</sub>	d <sub>1</sub>	l	k	S <sub>1</sub>	S <sub>a</sub>	g	f	F <sub>B</sub>	≈q
KW 40HFS	12.700	7.85	7.92	3.97	16.40	2.40	1.50	1.50	12.06	0.44	16000	0.62
KW 50HFS	15.875	9.40	10.16	5.08	20.40	2.17	2.00	2.00	15.08	0.70	26500	1.01
KW 60HFS	19.050	12.57	11.91	5.95	25.90	2.80	2.40	2.40	18.09	1.05	35000	1.45
KW 80HFS	25.400	15.75	15.88	7.93	32.76	3.67	3.10	3.10	24.13	1.78	72500	2.55
KW 100HFS	31.750	18.90	19.05	9.53	40.50	3.86	4.00	4.00	30.16	2.61	102900	3.95
KW 120HFS	38.100	25.22	22.30	11.11	50.40	6.00	4.80	4.80	36.19	3.92	142100	5.64
KW 140HFS	44.450	25.22	25.40	12.70	54.00	7.90	5.60	5.60	42.22	4.70	191100	7.38
KW 160HFS	50.800	31.55	28.58	14.29	65.60	4.30	6.40	6.40	48.26	6.36	260000	9.69
KW 180HFS	57.150	35.48	35.70	17.46	72.80	8.00	7.20	7.20	53.60	8.75	315000	13.30
KW 200HFS	63.500	54.94	39.68	19.84	79.50	6.00	8.00	8.00	60.00	10.73	420000	16.99
KW 240HFS	76.200	47.63	47.63	23.80	96.50	7.50	9.50	9.50	72.39	15.86	676000	25.00

# DIN 8188 / ISO 606-compliant HFS roller chains

## KW HFS duplex, KW HFS triplex

Drawings / product data (American standard)



KettenWulf roller chains for high-stress applications

KW HFS duplex, sizes according to American standard

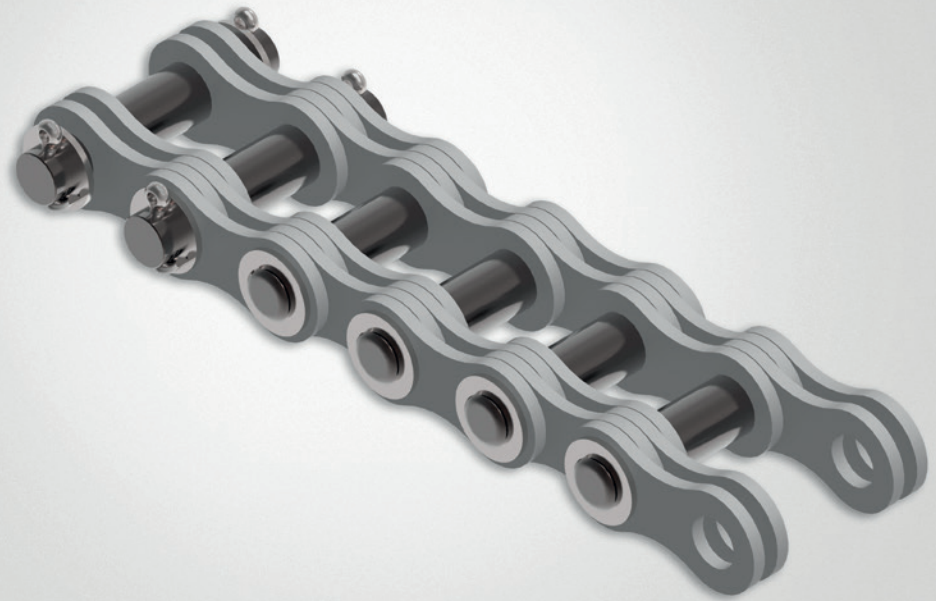
ISO 606 / DIN 8188

Designation	Pitch [mm]	Min. inner width [mm]	Max. protection roller $\varnothing$ [mm]	Max. pin $\varnothing$ [mm]	Max. pin length [mm]	Max. overhang connecting pin [mm]	Inner plate thickness [mm]	Outer plate thickness [mm]	Plate height [mm]	Transverse pitch [mm]	Bearing area [cm <sup>2</sup> ]	Min. breaking load [N]	Weight [kg/m]
Chain type	p	b <sub>1</sub>	d <sub>a</sub>	d <sub>1</sub>	l	k	S <sub>1</sub>	S <sub>2</sub>	g	e	f	F <sub>B</sub>	≈ q
KW 35-2HFS	9.520	4.78	5.08	3.59	22.28	1.58	1.28	1.28	9.04	10.13	0.27	20500	0.63
KW 40-2HFS	12.700	7.85	7.92	3.97	30.90	2.40	1.50	1.50	12.06	14.38	0.88	32000	1.22
KW 50-2HFS	15.875	9.40	10.16	5.03	38.80	2.40	2.00	2.00	15.08	18.11	1.40	53000	2.00
KW 60-2HFS	19.050	12.57	11.91	5.95	48.80	2.72	2.40	2.40	18.09	22.78	2.10	70000	2.87
KW 80-2HFS	25.400	15.75	15.88	7.93	61.96	4.10	3.20	3.20	24.13	29.29	3.56	145000	5.05
KW 100-2HFS	31.750	18.90	19.05	9.53	76.30	4.30	4.00	4.00	30.16	35.76	5.22	235800	7.86
KW 120-2HFS	38.100	25.22	22.30	11.11	96.00	4.37	4.80	4.80	36.19	45.44	7.84	284200	11.20
KW 140-2HFS	44.450	25.22	25.40	12.71	103.50	7.40	5.60	5.60	42.22	48.87	9.40	382200	15.35
KW 160-2HFS	50.800	31.55	28.58	14.29	124.00	4.30	6.40	6.40	48.00	58.55	19.26	520000	19.23
KW 180-2HFS	57.150	35.48	35.70	17.46	139.10	5.50	7.20	7.20	53.60	65.84	12.72	630000	26.41
KW 200-2HFS	63.500	54.94	39.68	19.84	152.00	6.00	8.00	8.00	60.00	71.55	32.20	840000	33.94
KW 240-2HFS	76.200	47.63	47.63	23.80	185.00	9.00	9.50	9.50	71.00	78.83	31.70	1352000	46.00

KW HFS triplex, sizes according to American standard

ISO 606 / DIN 8188

Chain type	p	b <sub>1</sub>	d <sub>a</sub>	d <sub>1</sub>	l	k	S <sub>1</sub>	S <sub>2</sub>	g	e	f	F <sub>B</sub>	≈ q
KW 40-3HFS	12.700	7.90	7.92	3.90	45.15	2.40	1.50	1.50	12.06	14.38	1.32	48000	1.82
KW 50-3HFS	15.875	9.50	10.16	5.08	56.60	2.75	2.00	2.00	15.08	18.11	2.10	79500	2.98
KW 60-3HFS	19.050	12.70	11.91	5.95	71.50	2.70	2.40	2.40	18.09	22.78	3.15	105000	4.28
KW 80-3HFS	25.400	15.85	15.88	7.93	91.50	3.90	3.10	3.10	24.13	29.29	5.34	217500	7.50
KW 100-3HFS	31.750	19.10	19.05	9.53	111.80	4.40	4.00	4.00	30.16	35.76	7.83	308700	11.75
KW 120-3HFS	38.100	25.40	22.30	11.11	141.00	4.96	4.80	4.80	36.19	45.44	11.76	426300	16.73
KW 140-3HFS	44.450	25.40	25.40	12.70	152.56	4.90	5.60	5.60	42.22	48.87	14.10	573000	21.93
KW 160-3HFS	50.800	31.65	28.35	14.29	183.08	4.56	6.40	6.40	48.26	58.55	19.26	735000	27.89
KW 180-3HFS	57.150	35.48	35.70	17.46	204.90	5.50	7.20	7.20	53.60	65.84	19.08	945000	39.48
KW 200-3HFS	63.500	38.10	39.67	19.84	222.00	9.00	8.00	8.00	60.00	71.55	32.20	1407000	48.90
KW 240-3HFS	76.200	47.63	47.63	23.80	272.00	9.00	9.50	9.50	71.00	87.83	47.60	2028000	72.70



## Non-Standard Chain (NSC) roller chains

The KettenWulf NSC “Non-Standard Chain” according to our factory standard are special chains for various different branches of industry. The chains listed below are the most common dimensions.

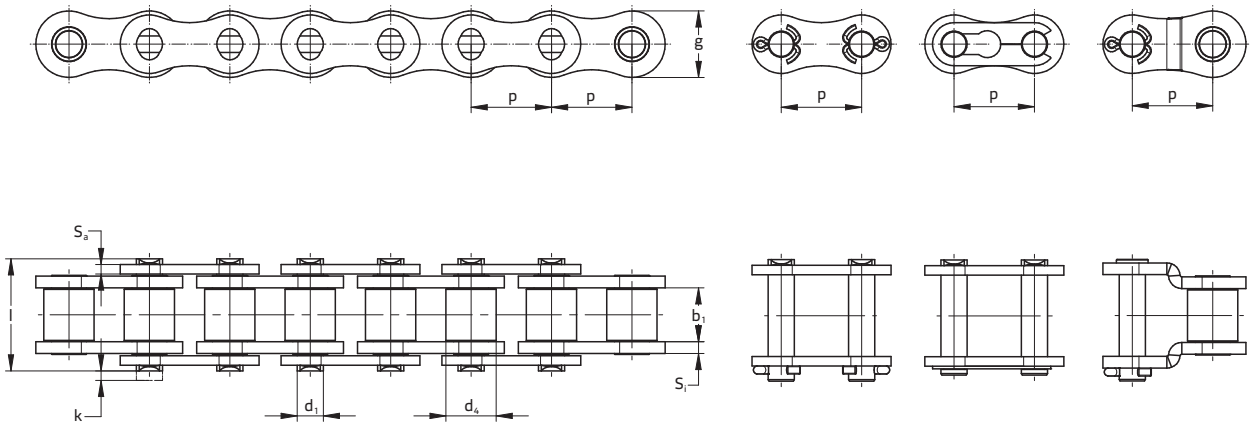
Other non-standard chains are available upon request.



# NSC roller chains

## KW NSC simplex

Drawings / product data

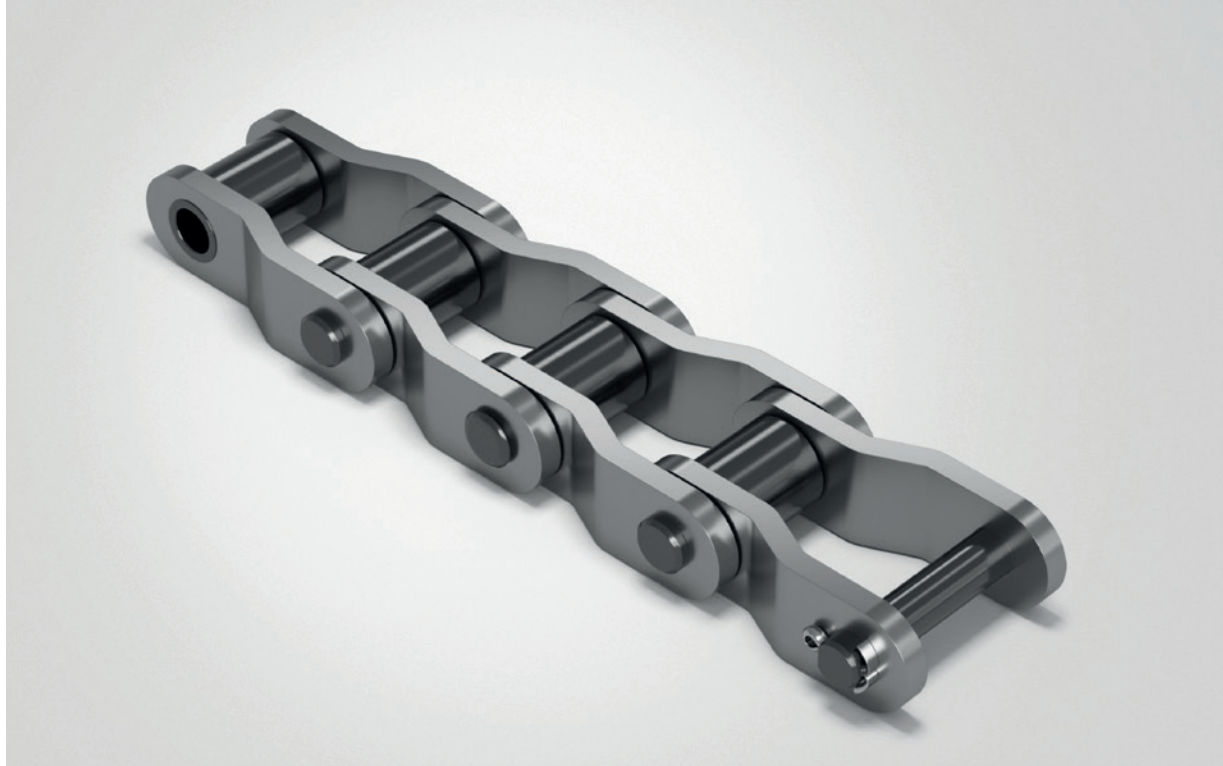


KettenWulf roller chains manufactured according to factory standard

### KW NSC roller chains

Designation	Pitch [mm]	Min. inner width [mm]	Max. protection roller $\varnothing$ [mm]	Max. pin $\varnothing$ [mm]	Max. pin length [mm]	Max. overhang connecting pin [mm]	Inner plate thickness [mm]	Outer plate thickness [mm]	Plate height [mm]	Bearing area [cm <sup>2</sup> ]	Min. breaking load [N]	Weight [kg/m]
Chain type	$p$	$b_1$	$d_6$	$d_1$	$l$	$k$	$S_1$	$S_a$	$g$	$f$	$F_b$	$\approx q$
KW 423	12.700	6.40	8.51	4.45	15.30	1.20	1.50	1.50	11.80	0.42	18200	0.60
KW 428D	12.700	7.75	8.51	4.45	16.60	1.10	1.60	1.50	11.60	0.50	20000	0.73
KW 12R*	19.050	11.68	12.07	6.10	24.90	3.60	2.40	2.40	18.10	1.05	45000	1.58
KW 12RA	19.050	11.68	12.07	6.10	24.90	3.60	2.40	2.40	16.80	1.05	40000	1.51
KW 16N14	25.400	12.70	14.00	7.00	28.50	2.00	3.00	3.00	19.70	1.52	45000	1.88
KW 16N159	25.400	12.70	15.88	8.28	30.80	3.80	3.50	3.10	21.00	2.00	54000	2.50
KW 16R	25.400	17.20	15.88	8.90	35.70	3.20	4.00	3.10	24.10	2.28	80000	3.10
KW H24B	38.100	25.40	25.40	14.63	60.10	4.80	7.30	6.30	35.93	5.91	247000	9.40
KW HX24B	38.100	25.40	25.40	14.63	62.00	3.20	8.00	6.40	36.20	5.91	247000	10.10

\* also available on reel from stock



## Rotary chains (RO)

KettenWulf rotary chains are manufactured in accordance with DIN 8182 / ANSI B29.10 and ISO 3512 and used under hard-wearing and very harsh conditions.

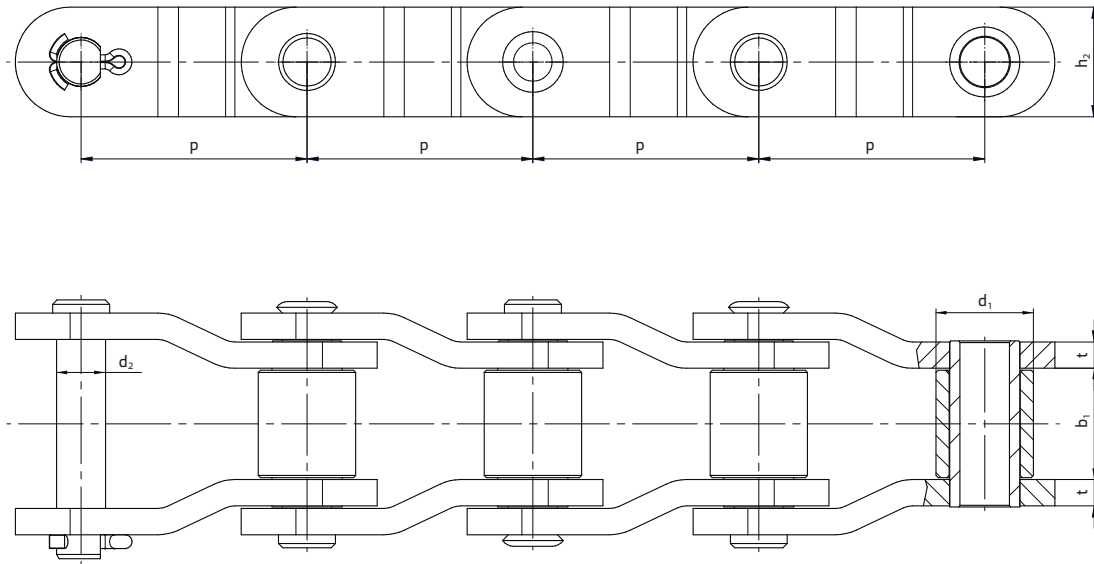
The specially selected high-alloy materials ensure maximum power transfer and are particularly resistant to impacts. Upon request, the pins can be induction-hardened to optimise the chain's wear resistance.

The typical field of application for KettenWulf rotary chains are bucket wheel devices and drum crushers, as well as the wood-processing industry.

# Rotary chains

## KW RO chains

Drawings / product data

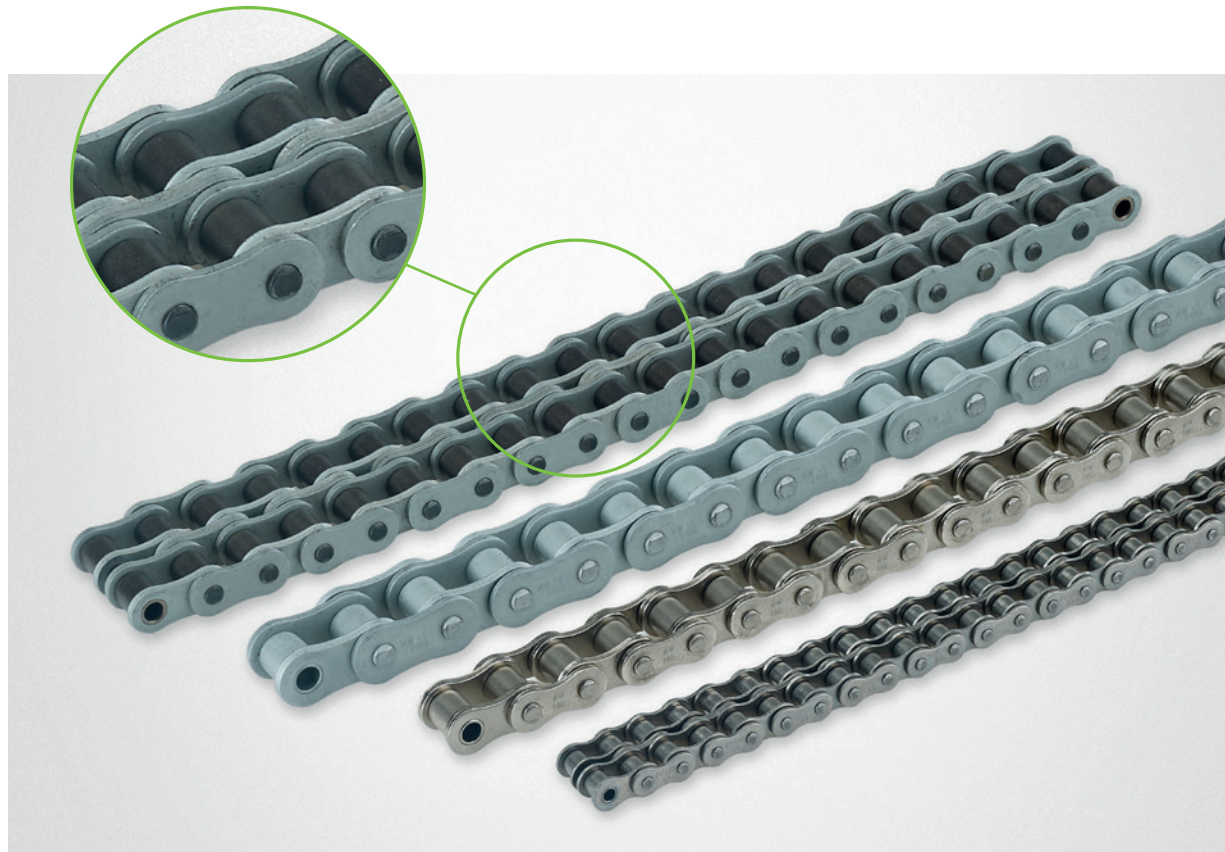


KettenWulf rotary chains

KW RO chains

ISO 3512 / DIN 8182 / ANSI B29.10

Designation	Pitch [mm]	Min. inner width [mm]	Max. protection roller $\varnothing$ [mm]	Max. pin $\varnothing$ [mm]	Inner plate thickness [mm]	Plate height [mm]	Min. breaking load [N]	Weight [kg/m]
Chain type	p	b <sub>1</sub>	d <sub>1</sub>	d <sub>2</sub>	t	h <sub>2</sub>	F <sub>B</sub>	≈ q
KW RO2510	78.100	36.90	31.75	16.00	8.00	40.00	271000	11.00
KW RO2512	77.900	38.50	41.28	19.05	10.00	60.00	400000	20.20
KW RO2814	88.900	36.90	44.45	22.25	14.00	60.00	556000	25.00
KW RO3214	103.200	48.00	44.45	22.00	14.00	55.00	476000	23.60
KW RO3315	103.450	47.60	45.24	23.85	15.00	60.00	650000	27.00
KW RO3618	114.300	50.80	57.15	27.97	15.00	75.00	894000	37.00
KW RO4020	127.000	68.30	63.50	31.78	18.00	90.00	1110000	54.00
KW RO4824	152.400	74.60	76.20	38.10	20.00	100.00	1600000	70.00



## Roller chains for special purposes

KettenWulf offers a range of rust-proof, stainless and corrosion-resistant roller chains for special purposes.

Such applications include:

- » outdoor facilities
- » installations requiring a cleanroom environment
- » corrosive environments
- » challenging weather conditions
- » temperature fluctuations
- » high humidity
- » salt water

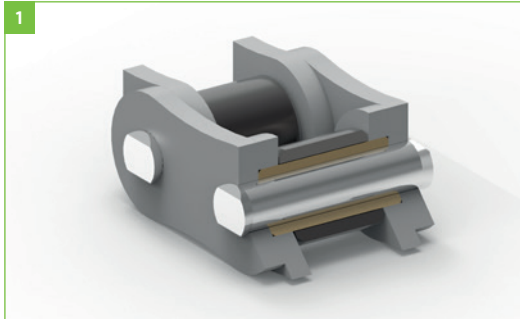
We also offer solutions for difficult servicing conditions with our maintenance-free or TGI-coated roller chains.

The use of sintered bushes and specially treated link components can further increase the service life of the chains.

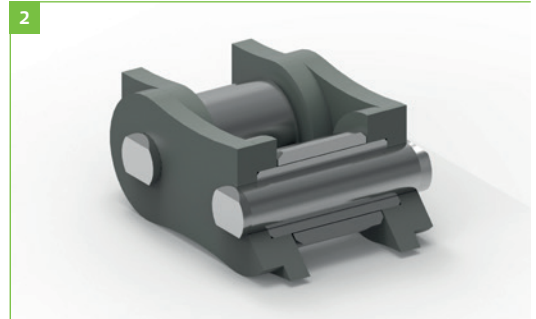


# Specific chain versions for different environmental conditions

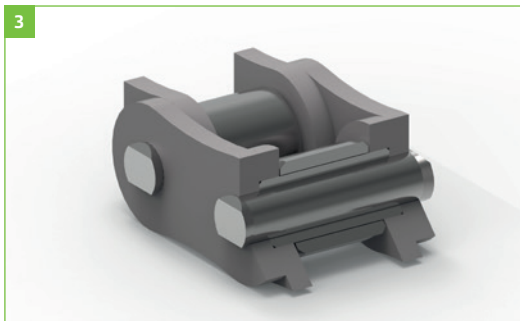
**Figure 1:**  
LF roller chain



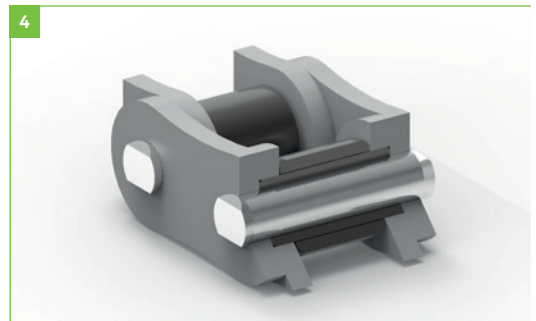
**Figure 2:**  
NP roller chain



**Figure 3:**  
SS roller chain



**Figure 4:**  
TGI roller chain

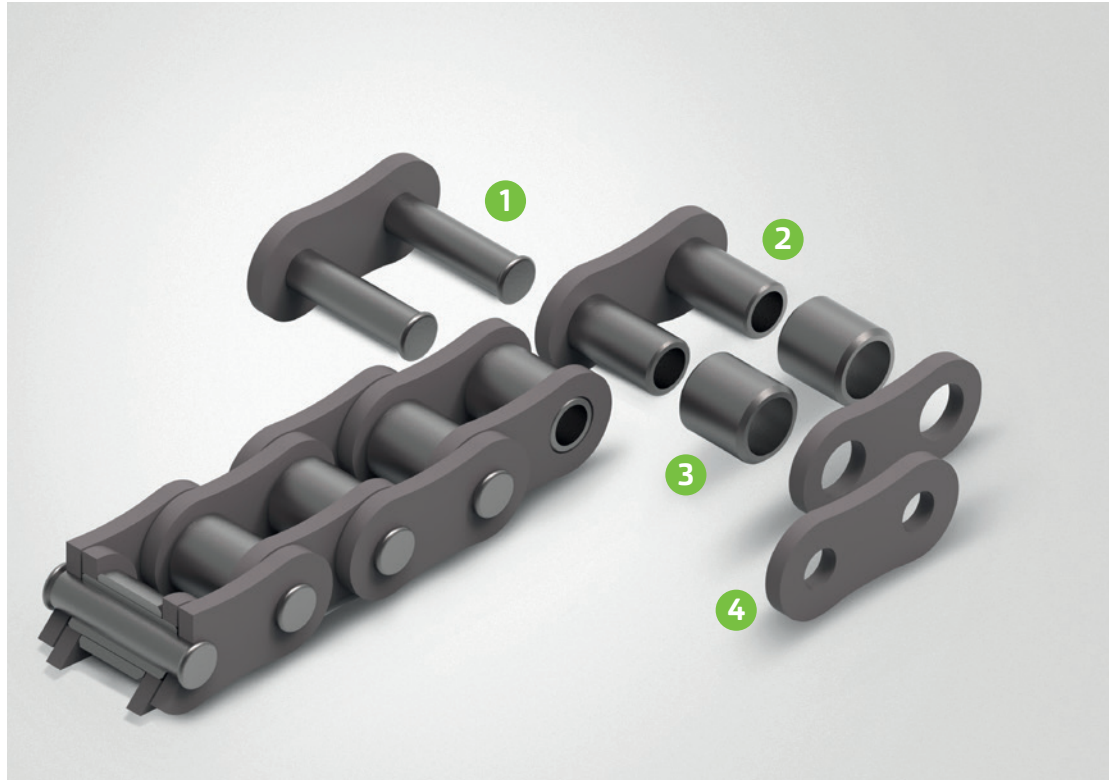


Formation of rust under different environmental conditions									
	Water			5% saline solution			1% ammonia		
	3 days	9 days	15 days	3 days	9 days	15 days	3 days	9 days	15 days
<b>Standard</b>									
<b>NP (Nickel plated)</b>									
<b>TGI</b>									
<b>SS 304</b>									

no rust   
 5-10%   
 20-30%   
 70-90%   
 100%

**SS roller chains**

- ① Pins made of stainless steel 1.4301
- ② Bushes made of stainless steel 1.4301
- ③ Seamless rollers made of stainless steel 1.4301
- ④ Link plates made of stainless steel 1.4301



## Stainless Steel (SS) roller chains

By default, our SS “stainless steel” roller chains are composed of basic components made of stainless steel 1.4301 (SUS 304) from stock. These chains are suitable for use in special acidic or basic environments.

The temperature range for operation of the SS roller chains is larger than that of standard chains. Since the components are not hardened, the breaking loads and the load capacity of the chains is lower than those of standard chains.

Due to the materials used in KettenWulf SS roller chains they are ideal for use in the food industry. All chains correspond to the dimensions stipulated in ISO 606.

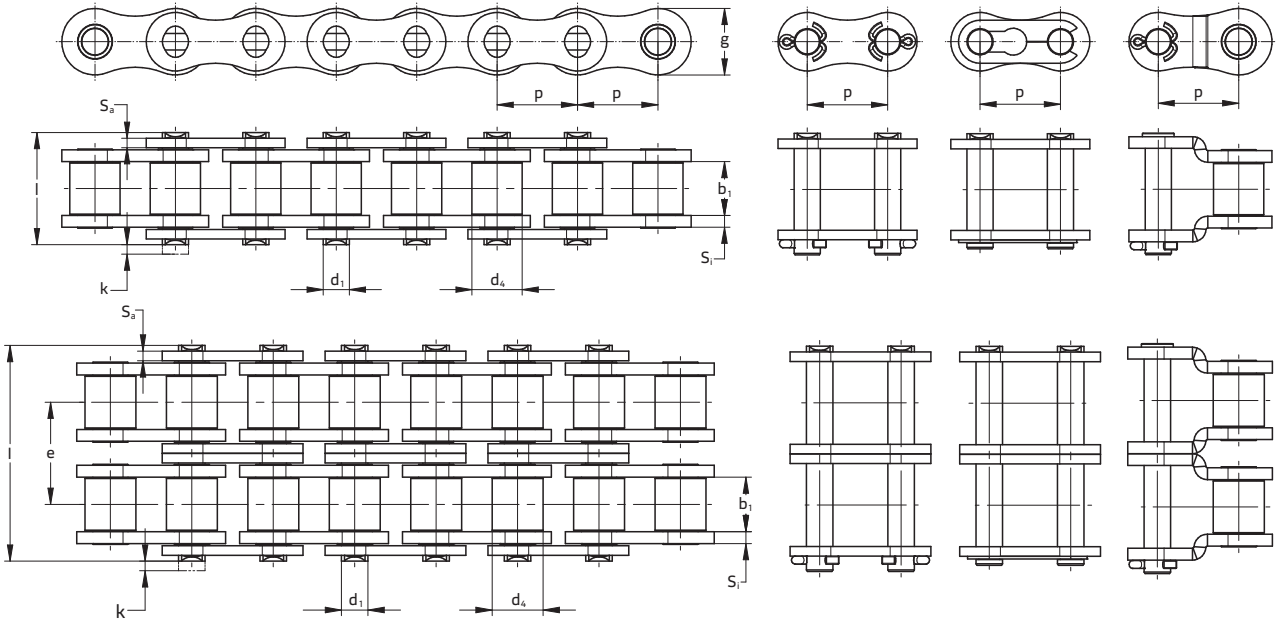
Upon request, the chains can be delivered with food-grade lubrication compliant with FDA classes H1 and H2.

Furthermore, made-to-order chains can be produced with SUS 316, SUS 400 or SUS 600 materials. SUS 316 is even more resistant to corrosion and heat than standard SUS 304 material and also anti-magnetic. SUS 400 and SUS 600 can be heat treated providing a higher resistance to wear and better fatigue strength properties.

# SS roller chains

## KW SS simplex, KW SS duplex

Drawings / product data (European & American standard)



### KettenWulf stainless steel roller chains

**KW SS simplex, sizes according to European standard** ISO 606 / DIN 8187

Designation	Pitch [mm]	Min. inner width [mm]	Max. protection roller Ø [mm]	Max. pin Ø [mm]	Max. pin length [mm]	Max. overhang connecting pin [mm]	Inner plate thickness [mm]	Outer plate thickness [mm]	Plate height [mm]	Transverse pitch [mm]	Bearing area [cm <sup>2</sup> ]	Min. breaking load [N]	Weight [kg/m]
Chain type	p	b <sub>i</sub>	d <sub>r</sub>	d <sub>p</sub>	l	k	S <sub>i</sub>	S <sub>e</sub>	g	e	f	F <sub>B</sub>	≈q
KW 06BSS	9.525	5.72	6.35	3.28	13.50	3.30	1.30	1.30	8.20	-	0.28	5800	0,38
KW 08BSS	12.700	7.75	8.51	4.45	17.00	2.30	1.50	1.50	11.75	-	0.50	10700	0,68
KW 10BSS	15.875	9.65	10.16	5.08	18.60	3.10	1.65	1.65	14.65	-	0.67	14700	0,86
KW 12BSS	19.050	11.68	12.07	5.72	22.70	2.70	1.80	1.80	16.10	-	0.89	18600	1,21
KW 16BSS	25.400	17.02	15.88	8.28	36.10	7.00	4.00	3.20	20.40	-	2.10	39200	2,66
KW C16BSS*	25.400	17.02	15.88	8.28	36.10	7.00	4.00	3.20	21.00	-	2.10	39200	2,80
KW 20BSS	31.750	19.56	19.05	10.19	40.20	7.20	4.50	3.20	26.00	-	2.96	58000	3,62
KW 24BSS	38.100	25.40	25.40	14.63	51.80	5.20	6.00	4.80	33.40	-	5.54	90000	7,00
KW 32BSS	50.800	31.00	29.21	17.81	65.20	7.80	6.90	6.30	42.00	-	8.10	150000	10,50

**KW SS simplex, sizes according to American standard** ISO 606 / DIN 8188

Chain type	p	b <sub>i</sub>	d <sub>r</sub>	d <sub>p</sub>	l	k	S <sub>i</sub>	S <sub>e</sub>	g	e	f	F <sub>B</sub>	≈q
KW 60SS	19.050	12.58	11.91	5.96	26.90	2.90	2.40	2.40	17.40	-	1.05	24300	1,44
KW 80SS	25.400	15.75	15.88	7.94	33.50	5.00	3.20	3.20	23.15	-	1.77	43100	2,83

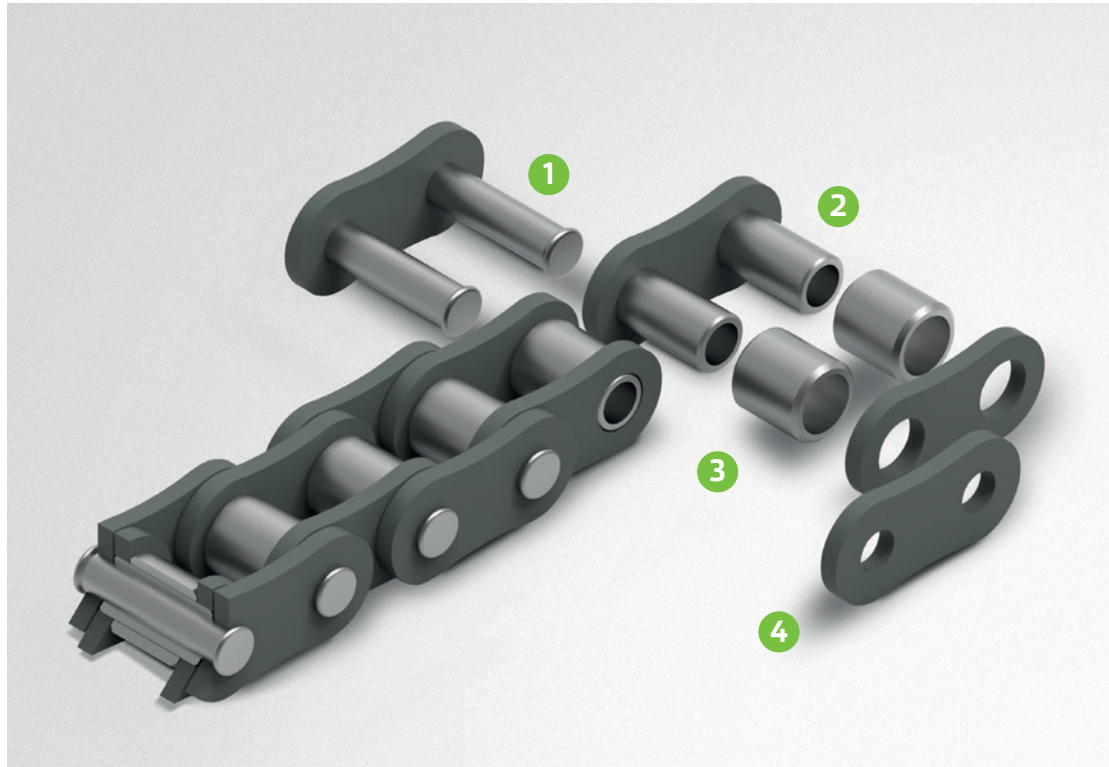
**KW SS duplex, sizes according to European standard** ISO 606 / DIN 8187

Chain type	p	b <sub>i</sub>	d <sub>r</sub>	d <sub>p</sub>	l	k	S <sub>i</sub>	S <sub>e</sub>	g	e	f	F <sub>B</sub>	≈q
KW 06B-2SS	9.525	5.72	6.35	3.28	23.80	2.00	1.30	1.10	8.20	10.24	0.56	11600	0,74
KW 08B-2SS	12.700	7.75	8.51	4.45	31.00	1.30	1.50	1.50	11.75	13.92	1.01	21400	1,34
KW 10B-2SS	15.875	9.65	10.16	5.08	36.20	2.00	1.65	1.65	14.65	15.69	1.34	29400	1,81
KW 12B-2SS	19.050	11.68	12.07	5.72	42.20	1.40	1.80	1.80	16.10	19.46	1.79	37200	2,40
KW 16B-2SS	25.400	17.02	15.88	8.28	68.00	3.60	4.00	3.20	20.40	31.88	4.24	78400	5,28
KW C16B-2SS*	25.400	17.02	15.88	8.28	68.00	3.60	4.00	3.20	21.00	31.88	4.24	78400	5,80

\* straight link plate    » other sizes available on request

**NP roller chains**

- ① Pins made of alloyed steel, case-hardened and grinded, with supplementary nickel plating
- ② Bush – seamless, cold-extruded bush, case-hardened and with supplementary nickel plating
- ③ Roller – seamless, cold-extruded roller, through hardend and with supplementary nickel plating
- ④ Link plates – stamped, quenched and tempered and subsequently ball blasted and with supplementary nickel-plating



## Nickel Plated (NP) roller chains

NP “Nickel Plated” roller chains are produced with the same specifications as the KW standard roller chains. In addition to that, all components receive a nickel plating.

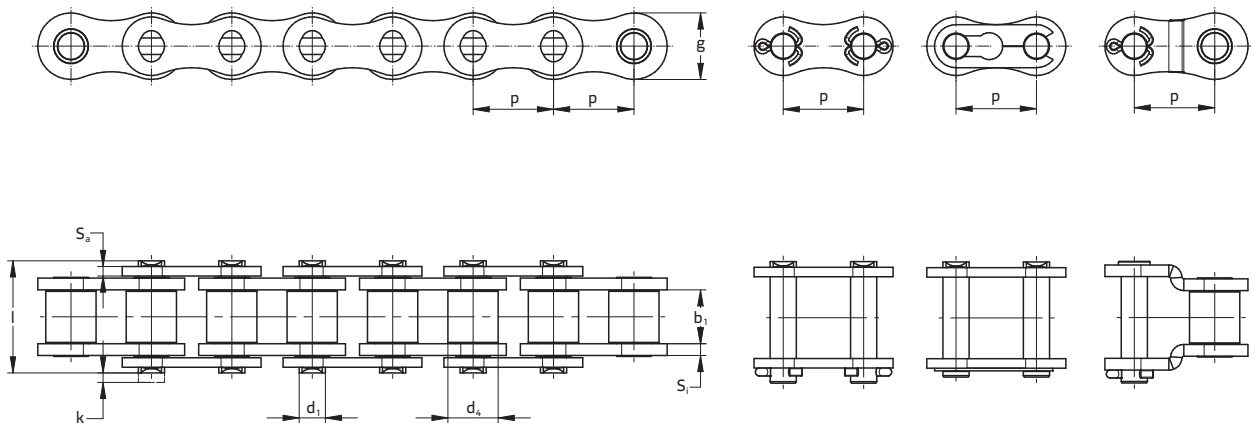
The coating has a complementary copper plating base layer for significantly higher corrosion protection properties than standard nickel coatings. Furthermore, the nickel-plated roller chains are free of chromium-6 components and hydrogen embrittlement.

Nickel-plated chains can also be supplied with FDA class H1 or FDA class H2 compliant lubrication upon request.

# NP roller chains

## KW NP simplex

Drawings / product data (European standard)



### KettenWulf corrosion-protected roller chains

KW NP simplex, sizes according to European standard

ISO 606 / DIN 8187

Designation	Pitch [mm]	Min. inner width [mm]	Max. protection roller $\varnothing$ [mm]	Max. pin $\varnothing$ [mm]	Max. pin length [mm]	Max. overhang connecting pin [mm]	Inner plate thickness [mm]	Outer plate thickness [mm]	Plate height [mm]	Bearing area [cm <sup>2</sup> ]	Min. breaking load [N]	Weight [kg/m]
Chain type	p	b <sub>1</sub>	d <sub>2</sub>	d <sub>1</sub>	l	k	S <sub>1</sub>	S <sub>2</sub>	g	f	F <sub>B</sub>	≈q
KW 08BNP	12.700	7.75	8.51	4.45	16.50	2.40	1.50	1.50	11.70	0.50	18000	0.70
KW 10BNP	15.875	9.65	10.16	5.08	18.80	2.60	1.50	1.50	14.60	0.67	22200	0.90
KW 12BNP	19.050	11.68	12.07	5.72	22.30	2.70	1.80	1.80	16.00	0.89	28900	1.20
KW 16BNP	25.400	17.02	15.88	8.28	35.40	3.40	3.70	3.00	21.00	2.10	60000	2.67
KW 20BNP	31.750	19.56	19.05	10.19	40.80	3.40	4.50	3.50	25.78	2.96	95000	3.81
KW 24BNP	38.100	25.40	25.40	14.63	53.30	4.70	6.00	5.50	33.25	5.54	160000	7.00
KW 32BNP	50.800	30.99	29.21	17.81	67.40	3.90	6.90	6.00	42.20	8.10	250000	9.97

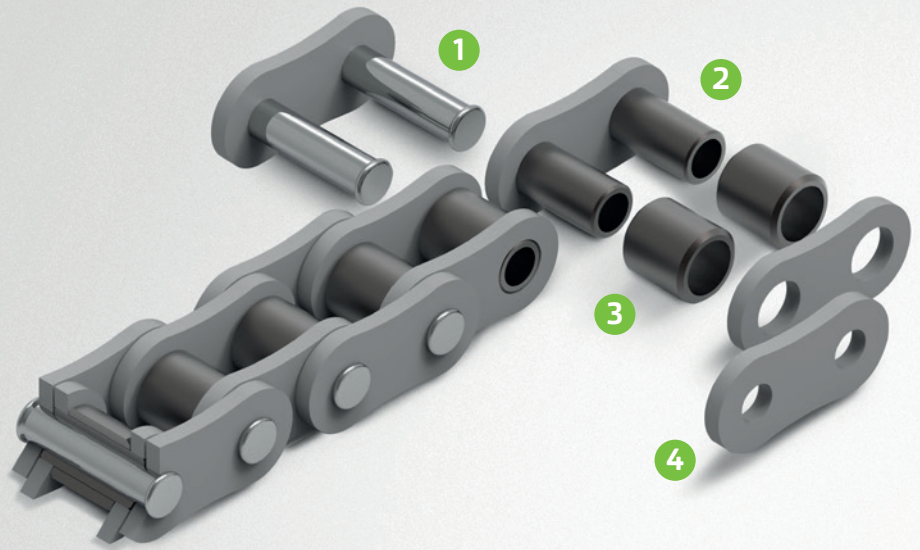
» Also available as duplex and triplex upon request.



**TGI roller chains**

- 1 Pins made of special alloyed steel, cold-extruded, case-hardened (pins starting from 1" are made of high-alloy heat-treated steel quenched and tempered), chrome-plated with high surface hardness and particularly smooth grinding
- 2 Bush – seamless, cold-extruded bush, case-hardened
- 3 Roller – seamless, cold-extruded roller, through hardend, ball blasted, extremely shock resistant
- 4 Link plates – high-precision stamped, quenched and tempered and subsequently ball blasted, holes calibrated with particularly high percentage contact area, the plate shape is wide waisted

All components are coated with Geomet®.



## Tri Guard Inchromised (TGI) roller chains

The KettenWulf TGI "Tri Guard Inchromised" coated chain is suited for the highest requirements in corrosion resistance, wear resistance and fatigue strength. It represents the state-of-the-art standard on the market for applications under hard-wearing and aggressive conditions.

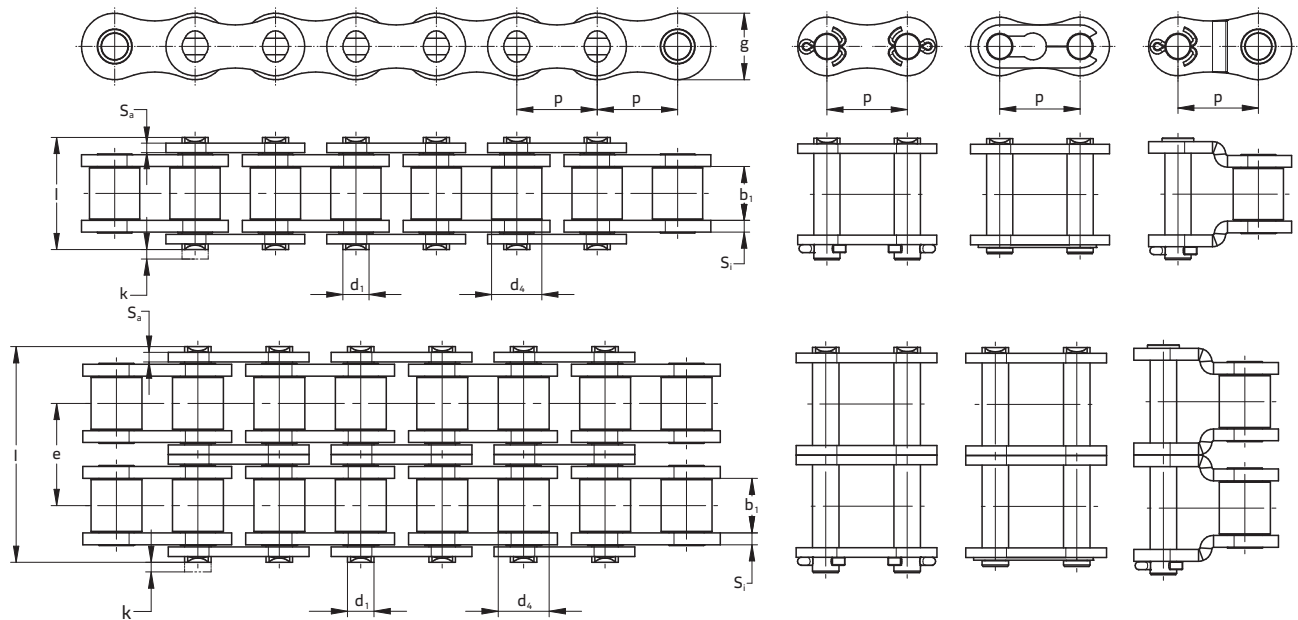
The materials and the manufacturing method used are the same as for the KW HFS chain and guarantee the same high level of fatigue strength. In addition, all components receive a special Geomet® coating. This type of coating achieves the unmatched corrosion resistance level of more than 500 hours in a salt spray test.

Compared to the HFS chain, the pin material has been further optimised by a layer of chrome plating. This gives the pin a particularly hard and smooth surface. With these features, the chain is highly wear resistant and exposes optimal emergency operation properties.

# TGI roller chains

## KW TGI simplex, KW TGI duplex

Drawings / product data (European & American standard)



### KettenWulf wear-resistant and corrosion-protected roller chains

**KW TGI simplex, sizes according to European standard** ISO 606 / DIN 8187

Designation	Pitch [mm]	Min. inner width [mm]	Max. protection roller $\varnothing$ [mm]	Max. pin $\varnothing$ [mm]	Max. pin length [mm]	Max. overhang connecting pin [mm]	Inner plate thickness [mm]	Outer plate thickness [mm]	Plate height [mm]	Transverse pitch [mm]	Bearing area [cm <sup>2</sup> ]	Min. breaking load [N]	Weight [kg/m]
Chain type	$p$	$b_1$	$d_2$	$d_1$	$l$	$k$	$S_1$	$S_2$	$g$	$e$	$f$	$F_B$	$\approx q$
KW 08BTGI	12.700	7.75	8.51	4.45	17.00	1.60	1.50	1.50	11.80	-	0.50	17800	0.75
KW 10BTGI	15.875	9.65	10.16	5.08	19.60	2.50	1.65	1.65	14.70	-	0.67	24400	0.98
KW 12BTGI	19.050	11.68	12.07	5.72	22.70	3.30	1.80	1.80	16.10	-	0.89	28900	1.26
KW 16BTGI	25.400	17.02	15.88	8.28	36.10	3.10	4.00	3.20	21.00	-	2.10	72500	2.83
KW 20BTGI	31.750	19.56	19.05	10.19	43.20	4.40	4.50	3.50	26.40	-	2.96	105000	3.94
KW 24BTGI	38.100	25.40	25.40	14.63	53.40	5.50	6.00	4.70	33.40	-	5.54	175000	7.21
KW 32BTGI	50.800	30.99	29.21	17.81	67.40	3.90	6.90	6.00	42.20	-	8.10	265000	9.97

**KW TGI duplex, sizes according to European standard** ISO 606 / DIN 8187

Chain type	$p$	$b_1$	$d_2$	$d_1$	$l$	$k$	$S_1$	$S_2$	$g$	$e$	$f$	$F_B$	$\approx q$
KW 08B-2TGI	12.700	7.75	8.51	4.45	31.00	1.60	1.50	1.50	11.80	13.92	1.01	35600	1.45
KW 10B-2TGI	15.875	9.65	10.16	5.08	36.20	2.70	1.65	1.65	14.70	16.59	1.34	48800	1.93
KW 12B-2TGI	19.050	11.68	12.07	5.72	42.20	3.00	1.80	1.80	16.10	19.46	1.79	57800	2.49
KW 16B-2TGI	25.400	17.02	15.88	8.28	68.00	3.40	4.00	3.20	21.00	31.88	4.21	145000	5.28
KW 20B-2TGI	31.750	19.56	19.05	10.19	79.00	5.10	4.50	3.50	26.40	36.45	5.91	210000	7.78
KW 24B-2TGI	38.100	25.40	25.40	14.63	101.00	6.70	6.00	4.70	33.40	48.36	11.08	350000	14.31
KW 32B-2TGI	50.800	30.99	29.21	17.81	126.00	3.80	6.90	6.00	42.20	58.55	16.21	530000	19.59

>> Also available as triplex upon request.

**KW TGI simplex, sizes according to American standard** ISO 606 / DIN 8188

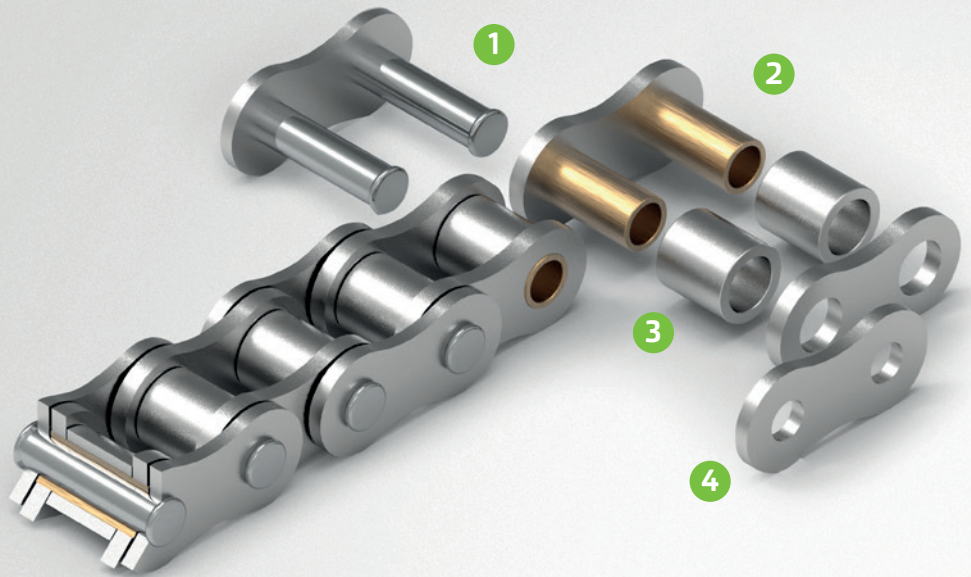
Chain type	$p$	$b_1$	$d_2$	$d_1$	$l$	$k$	$S_1$	$S_2$	$g$	$e$	$f$	$F_B$	$\approx q$
KW 40TGI	12.700	7.90	7.90	3.97	16.32	2.40	1.50	1.50	12.06	-	0.44	17200	0.62
KW 50TGI	15.875	9.50	10.14	5.08	20.30	2.17	2.00	2.00	15.08	-	0.70	27400	1.01
KW 60TGI	19.050	12.70	11.88	5.95	25.26	2.80	2.40	2.40	18.09	-	1.05	38200	1.45
KW 80TGI	25.400	15.85	15.84	7.93	32.76	3.37	3.20	3.20	24.13	-	1.78	72500	2.55

>> Also available in larger dimensions and as duplex / triplex upon request.

**LF roller chains**

- 1 Pins made of alloyed steel, cold-extruded pins starting from 1 ½" are made of highly alloyed heat-treated steel, nickel-plated with high surface hardness and particularly smooth grinding
- 2 Bush – self-lubricating, oil impregnated bush with special lubricant
- 3 Roller – seamless, cold-extruded roller, through hardend, ball blasted, extremely shock resistant
- 4 Link plates – high-precision stamped, quenched and tempered and subsequently ball-blasted, holes calibrated with particularly high percentage contact area

All components are nickel-plated for optimal corrosion protection



## Lube free (LF) roller chains

The new generation of KettenWulf LF "Lube Free" chains is based on the manufacturing technology and material of the standard KW chain.

In addition to the standard features, this chain is characterised by a special oil-impregnated sintered bush which forms a particularly wear-resistant and long-lived chain link in combination with the unique smoothness and hardness of the specially treated pin.

Since the special lubricant for sintered bearings will only escape from the bush when exposed to friction and temperature, these roller chains are delivered with a thin layer of initial lubrication. In order to ensure a very high level of corrosion protection, all components are plated with nickel, in addition.

The operating temperature range of the chains is between -30°C and +160°C. LF chains are available for an extended temperature range upon request. The functional dimensions are those stipulated in ISO 606. Furthermore, KettenWulf LF roller chains can be delivered with straight link plates. These are ideally suited for pallet and skid transport.

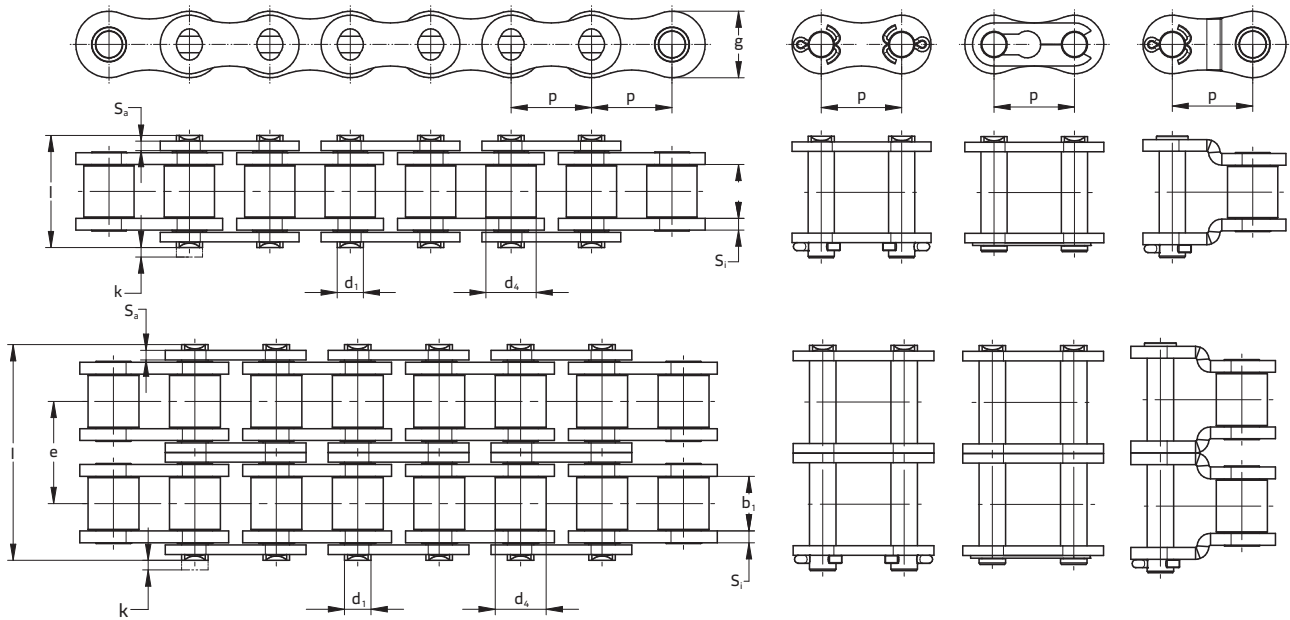
Made-to-order KW LF chains can also be produced on the basis of the KettenWulf TGI chain. This version is best suited for all critical applications requiring particularly high fatigue strength, maximum corrosion protection and a special resistance to highest speeds.

Please do not hesitate to contact us for further information.

# DIN 8187 / ISO 606-compliant LF roller chains

## KW LF simplex, KW LF duplex, KW LF triplex

Drawings / product data (European & American standard)



### KettenWulf lubrication-free roller chains

KW LF simplex, sizes according to European standard

ISO 606 / DIN 8187

Designation	Pitch [mm]	Min. inner width [mm]	Max. protection roller $\varnothing$ [mm]	Max. pin $\varnothing$ [mm]	Max. pin length [mm]	Max. overhang connecting pin [mm]	Inner plate thickness [mm]	Outer plate thickness [mm]	Plate height [mm]	Transverse pitch [mm]	Bearing area [cm <sup>2</sup> ]	Min. breaking load [N]	Weight [kg/m]
Chain type	$p$	$b_1$	$d_4$	$d_1$	$l$	$k$	$S_1$	$S_2$	$g$	$e$	$f$	$F_b$	$\approx q$
KW 08BLF	12.700	7.75	8.51	4.45	17.00	1.60	1.50	1.50	11.80	-	0.50	17800	0.75
KW 10BLF	15.875	9.65	10.16	5.08	19.60	2.50	1.65	1.65	14.70	-	0.67	22200	0.98
KW 12BLF	19.050	11.68	12.07	5.72	22.70	3.30	1.80	1.80	16.10	-	0.89	28900	1.26
KW C12BLF*	19.050	11.68	12.07	5.72	22.70	3.30	1.80	1.80	16.10	-	0.89	28900	1.26
KW 16BLF	25.400	17.02	15.88	8.28	36.10	3.10	4.00	3.20	21.00	-	2.10	60000	2.83
KW C16BLF*	25.400	17.02	15.88	8.28	36.10	3.10	4.00	3.20	21.00	-	2.10	60000	2.83
KW 20BLF	31.750	19.56	19.05	10.19	43.20	4.40	4.50	3.50	26.40	-	2.96	95000	3.94
KW 24BLF	38.100	25.40	25.40	14.63	53.40	5.50	6.00	4.70	33.40	-	5.54	160000	7.21
KW C24BLF*	38.100	25.40	25.40	14.63	53.40	5.50	6.00	4.70	33.40	-	5.54	160000	7.21
KW 32BLF	50.800	30.99	29.21	17.81	67.40	3.90	6.90	6.00	42.20	-	8.10	250000	10.00

KW LF duplex, KW LF triplex, sizes according to European standard

ISO 606 / DIN 8187

Chain type	$p$	$b_1$	$d_4$	$d_1$	$l$	$k$	$S_1$	$S_2$	$g$	$e$	$f$	$F_b$	$\approx q$
KW 08B-2LF	12.700	7.75	8.51	4.45	31.00	1.60	1.50	1.50	11.80	13.92	1.01	31100	1.45
KW 10B-2LF	15.875	9.65	10.16	5.08	36.20	2.70	1.65	1.65	14.70	16.59	1.34	44500	1.93
KW C10B-2LF*	15.875	9.65	10.16	5.08	36.20	2.70	1.65	1.65	14.70	16.59	1.34	44500	1.93
KW 12B-2LF	19.050	11.68	12.07	5.72	42.20	3.00	1.80	1.80	16.10	19.46	1.79	57800	2.49
KW C12B-2LF*	19.050	11.68	12.07	5.72	42.20	3.00	1.80	1.80	16.10	19.46	1.79	57800	2.49
KW 16B-2LF	25.400	17.02	15.88	8.28	68.00	3.40	4.00	3.20	21.00	31.88	4.21	106000	5.28
KW 20B-2LF	31.750	19.56	19.05	10.19	79.00	5.10	4.50	3.50	26.40	36.45	5.91	170000	7.78
KW 24B-2LF	38.100	25.40	25.40	14.63	101.00	6.40	6.00	4.70	33.40	48.36	11.08	280000	14.31
KW C24B-2LF*	38.100	25.40	25.40	14.63	101.00	6.40	6.00	4.70	33.40	48.36	5.54	280000	14.31
KW 32B-2LF	50.800	30.99	29.21	17.81	126.00	4.70	7.00	6.00	42.20	58.55	16.21	450000	19.59
KW 20B-3LF	31.750	19.56	19.05	10.19	116.00	4.60	4.50	3.50	26.40	36.45	8.87	250000	11.66

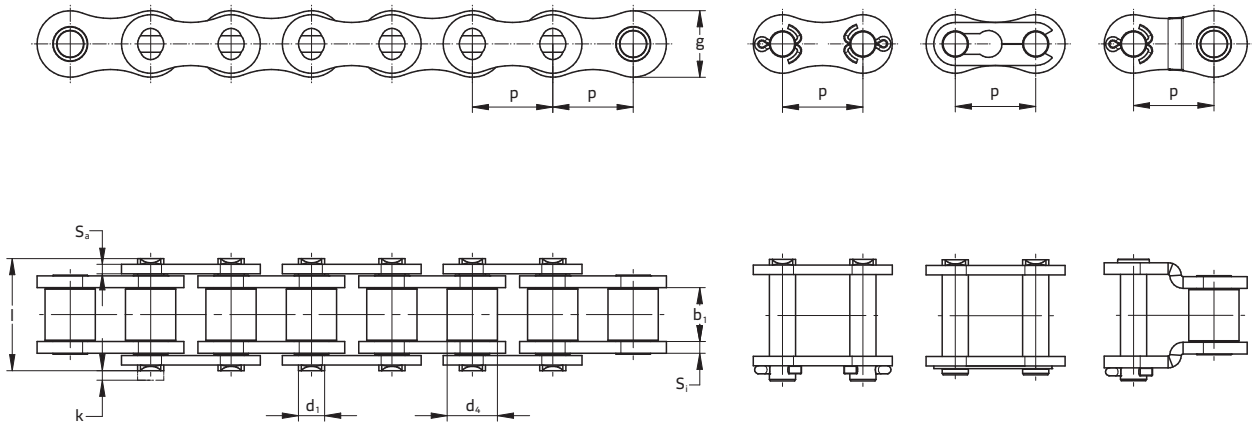
\* with straight link plates

» All chains are also available as triplex upon request.

# DIN 8188 / ISO 606-compliant LF roller chains

## KW LF simplex

Drawings / product data (American standard)



### KettenWulf lubrication-free roller chains

KW LF simplex, sizes according to American standard

ISO 606 / DIN 8188

Designation	Pitch [mm]	Min. inner width [mm]	Max. protection roller $\varnothing$ [mm]	Max. pin $\varnothing$ [mm]	Max. pin length [mm]	Max. overhang connecting pin [mm]	Inner plate thickness [mm]	Outer plate thickness [mm]	Plate height [mm]	Bearing area [cm <sup>2</sup> ]	Min. breaking load [N]	Weight [kg/m]
Chain type	p	b <sub>i</sub>	d <sub>4</sub>	d <sub>1</sub>	l	k	S <sub>i</sub>	S <sub>o</sub>	g	f	F <sub>B</sub>	≈q
KW 50LF	15.870	9.50	10.14	5.08	20.30	2.17	2.00	2.00	15.08	0.70	21800	1.00
KW 60LF	19.050	12.70	11.88	5.95	25.26	2.80	2.40	2.40	18.09	1.05	31300	1.45
KW 80LF	25.400	15.85	15.84	7.93	32.76	3.67	3.20	3.20	24.13	1.78	55600	2.55
KW 100LF	31.750	19.10	19.00	9.53	40.08	3.86	4.00	4.00	30.16	2.61	87000	4.00
KW 120LF	38.100	25.40	22.20	11.11	49.92	6.00	4.80	4.80	36.19	3.92	125000	5.64

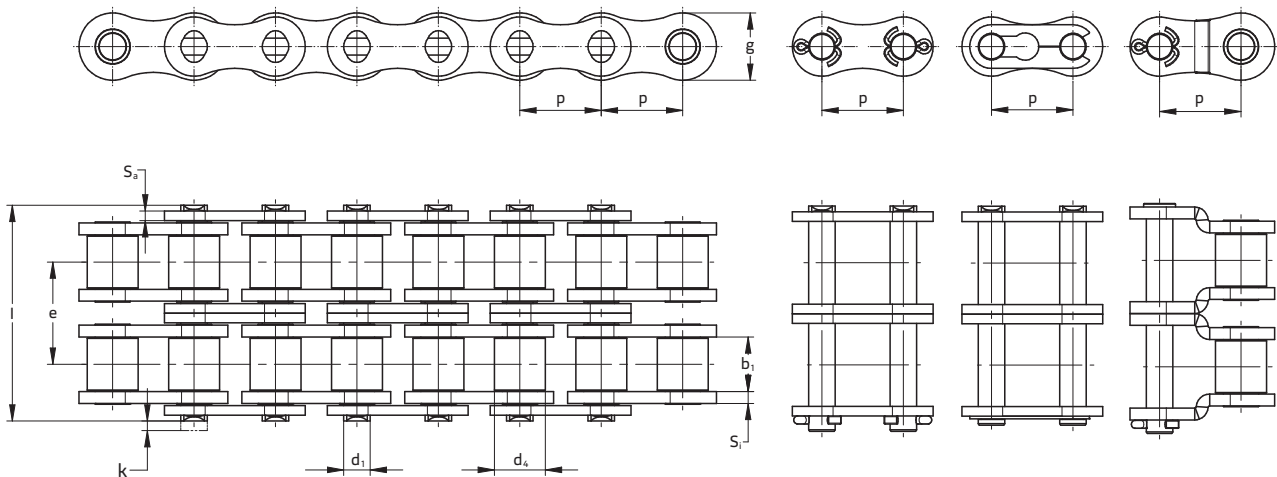
» We can also produce larger LF roller chains according to American standard upon request.



# DIN 8188 / ISO 606-compliant LF roller chains

## KW LF duplex

Drawings / product data (American standard)



### KettenWulf lubrication-free roller chains

#### KW LF duplex, sizes according to American standard

ISO 606 / DIN 8188

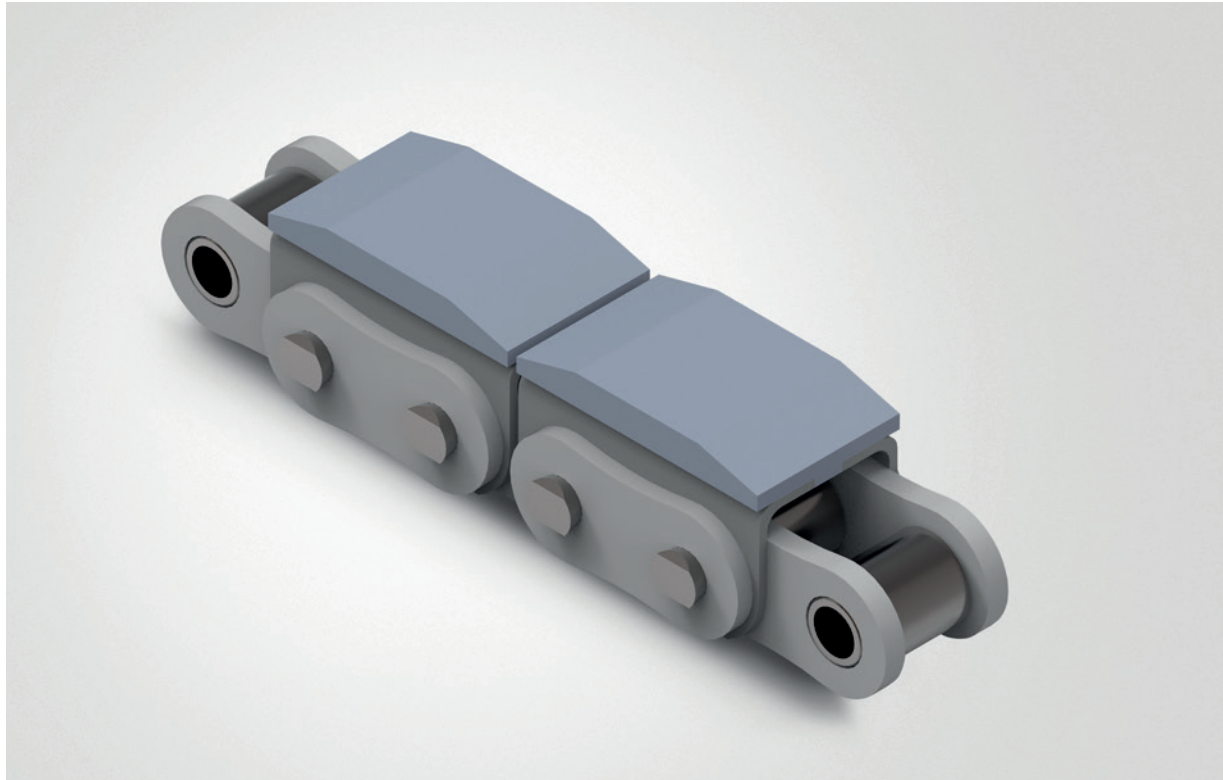
Designation	Pitch [mm]	Min. inner width [mm]	Max. protection roller $\varnothing$ [mm]	Max. pin $\varnothing$ [mm]	Max. pin length [mm]	Max. overhang connecting pin [mm]	Inner plate thickness [mm]	Outer plate thickness [mm]	Plate height [mm]	Transverse pitch [mm]	Bearing area [cm <sup>2</sup> ]	Min. breaking load [N]	Weight [kg/m]
Chain type	p	b <sub>1</sub>	d <sub>e</sub>	d <sub>1</sub>	l	k	S <sub>1</sub>	S <sub>2</sub>	g	e	f	F <sub>B</sub>	≈q
KW 80-2LF	25.400	15.85	15.40	7.93	61.96	4.10	3.20	3.20	24.13	29.29	3.56	111200	5.05
KW 100-2LF	31.750	19.10	19.04	9.53	75.80	4.30	4.00	4.00	30.16	35.76	5.22	174000	7.86
KW 120-2LF	38.100	25.40	22.20	11.11	95.86	4.37	4.80	4.80	36.19	45.44	7.84	250000	11.20

#### KW LF triplex, sizes according to American standard

ISO 606 / DIN 8188

Designation	Pitch [mm]	Min. inner width [mm]	Max. protection roller $\varnothing$ [mm]	Max. pin $\varnothing$ [mm]	Max. pin length [mm]	Max. overhang connecting pin [mm]	Inner plate thickness [mm]	Outer plate thickness [mm]	Plate height [mm]	Transverse pitch [mm]	Bearing area [cm <sup>2</sup> ]	Min. breaking load [N]	Weight [kg/m]
Kettentyp	p	b <sub>1</sub>	d <sub>e</sub>	d <sub>1</sub>	l	k	S <sub>1</sub>	S <sub>2</sub>	g	e	f	F <sub>B</sub>	≈q
KW 120-3LF	38.100	25.40	22.30	11.11	141.00	4.96	4.80	4.80	36.19	45.44	11.76	375000	16.73

» We can also produce larger LF roller chains according to American standard upon request.



## Chains for conveyor applications

Roller chains are very versatile. Apart from their standard use as drive chains, certain roller chain versions can also be used for conveyor applications.

The functional dimensions are basically the same as those for the standard ISO 606-compliant roller chain. The chains are capable of conveying material because they are available with various design versions of attachments and rollers. The **KettenWulf portfolio** “Chains for conveyor applications” the following:

- » roller chains with straight link plates
- » roller chains with elastomer profiles
- » roller chains with plastic link plates
- » agricultural machinery chains
- » deep link chains
- » side-flexing conveyor chains (CC chains)
- » welded steel chains (WSC)

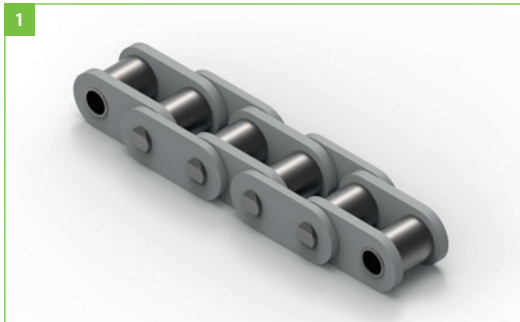
KettenWulf welded steel chains and CC600 crate conveyor chains round off our conveyance tasks product portfolio.

If you should not find the right chain for your particular conveyance task in our comprehensive product range, please get in touch with us.

## Specific chain versions for different conveyor applications

Roller chains are often used as a conveyor chain. For this purpose, the link plates have a straight design. Vulcanised elastomer profiles ensure the smooth transport of the conveyed material.

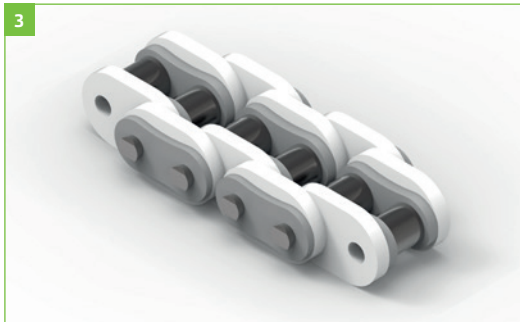
**Figure 1:**  
Roller chain with straight link plates



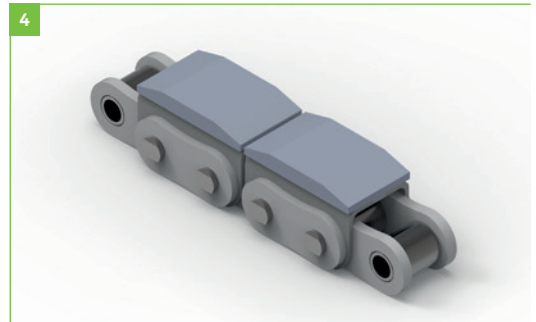
**Figure 2:**  
double pitch roller chain



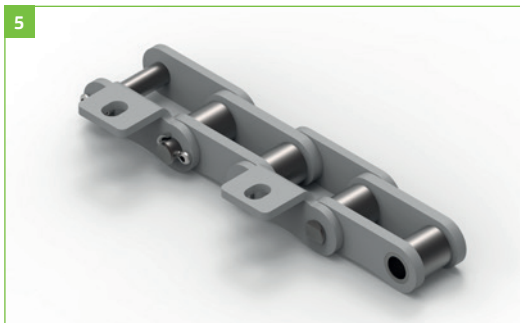
**Figure 3:**  
Roller chain with plastic link plates



**Figure 4:**  
Roller chain with elastomer profile



**Figure 5:**  
Agricultural machinery chain



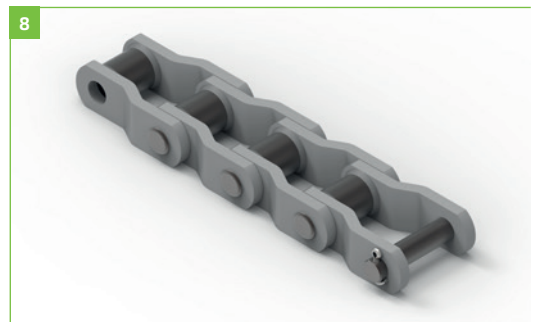
**Figure 6:**  
Deep link chain

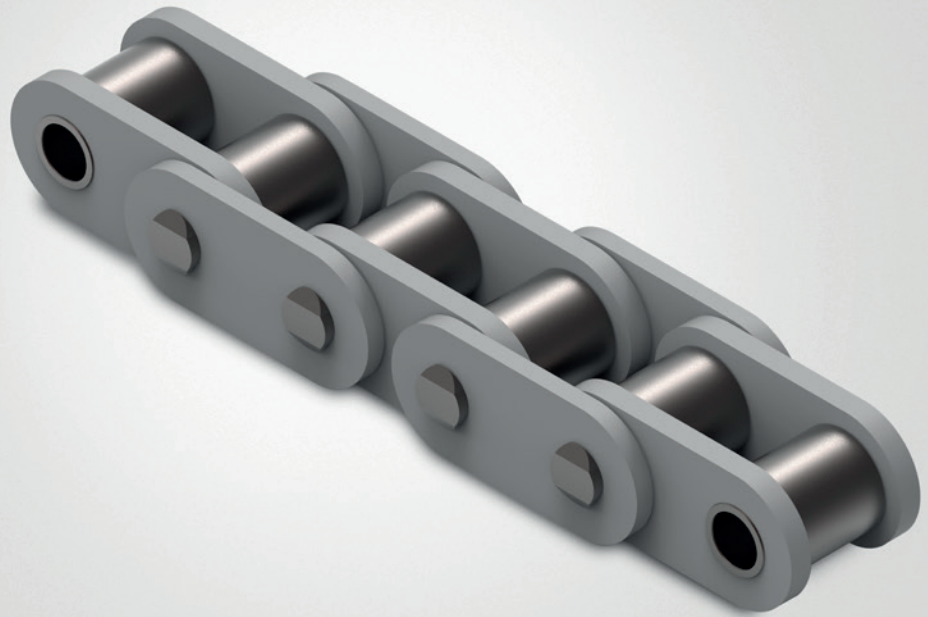


**Figure 7:**  
Side-flexing conveyor chain (CC)



**Figure 8:**  
Welded chain with cranked link plates (WSC)





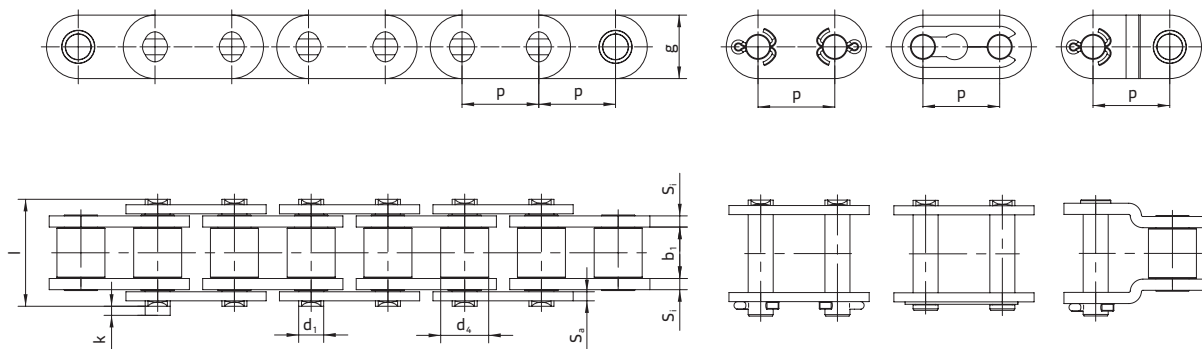
## Conveyor (C) roller chains

KettenWulf "Conveyor Chain" transport chains with straight link plates are based on the standard roller chain. Because of the straight design of the link plates they are particularly well suited as transport and conveyor chains.

# C roller chains

## KW C Simplex – conveyor chains with straight link plates

Drawings / product data



KettenWulf conveyor chains with straight link plates

KW C simplex, sizes according to European standard

ISO 606 / DIN 8187

Designation	Pitch [mm]	Min. inner width [mm]	Max. roller Ø [mm]	Max. pin Ø [mm]	Max. pin length [mm]	Max. overhang connecting pin [mm]	Inner plate thickness [mm]	Outer link plate thickness [mm]	Plate height [mm]	Bearing area [cm <sup>2</sup> ]	Min. breaking load [N]	Weight [kg/m]
Chain type	p	b <sub>1</sub>	d <sub>2</sub>	d <sub>1</sub>	l	k	S <sub>1</sub>	S <sub>2</sub>	g	f	F <sub>B</sub>	≈ q
KW C08B	12.700	7.75	8.51	4.45	16.50	2.40	1.50	1.50	11.70	0.50	18000	0.75
KW C10B	15.875	9.65	10.16	5.08	18.80	2.60	1.50	1.50	14.60	0.67	22200	1.00
KW C12B	19.050	11.68	12.07	5.72	22.30	2.70	1.80	1.80	16.00	0.89	28900	1.29
KW C16B21*	25.400	17.02	15.88	8.28	35.40	3.40	3.70	3.00	21.00	2.10	60000	2.95
KW C16B24*	25.400	17.02	15.88	8.28	35.40	3.40	3.70	3.00	24.00	2.10	70000	3.30
KW C20B	31.750	19.56	19.05	10.19	40.80	3.70	4.50	3.50	25.78	2.96	95000	4.25
KW C24B	38.100	25.40	25.40	14.63	53.30	4.70	6.00	5.00	33.25	5.54	160000	7.50
KW C32B	50.800	30.99	29.21	17.81	65.20	5.80	7.00	6.40	42.00	8.10	250000	11.20

\* Also available on reel from stock

» All chain types are also available as low-maintenance (LF) versions.

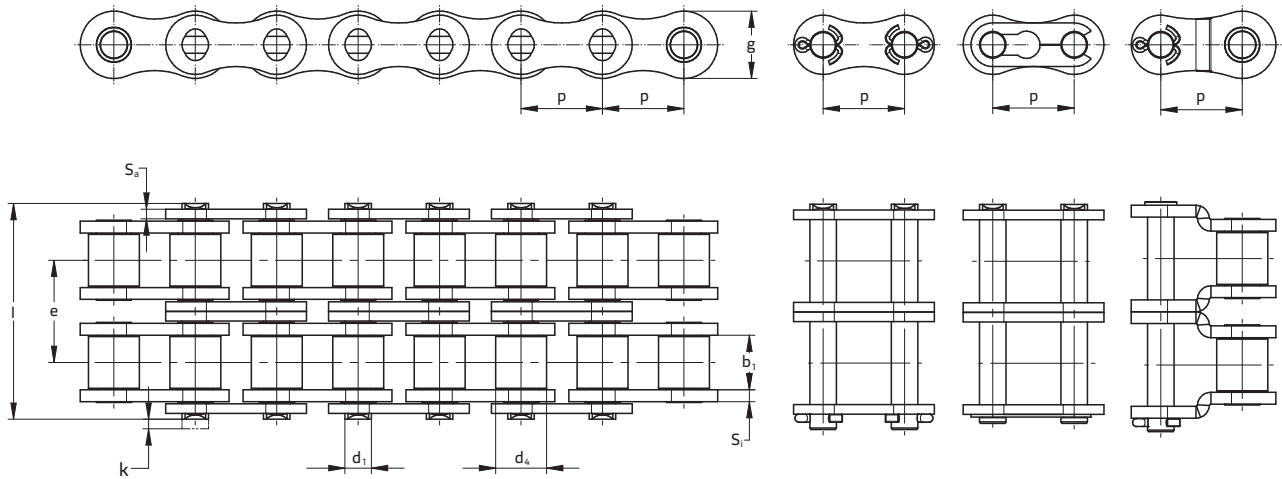
» Roller chains in triplex design available upon request.



# C roller chains

## KW C duplex – conveyor chains with straight link plates

Drawings / product data



KettenWulf conveyor chains with straight link plates

KW C duplex, sizes according to European standard

ISO 606 / DIN 8187

Designation	Pitch [mm]	Min. inner width [mm]	Max. roller Ø [mm]	Max. pin Ø [mm]	Max. pin length [mm]	Max. overhang connecting pin [mm]	Inner plate thickness [mm]	Outer plate thickness [mm]	Plate height [mm]	Transverse pitch [mm]	Bearing area [cm <sup>2</sup> ]	Min.-breaking load [N]	Weight [kg/m]
Chain type	p	b <sub>1</sub>	d <sub>4</sub>	d <sub>1</sub>	l	k	S <sub>r</sub>	S <sub>a</sub>	g	e	f	F <sub>B</sub>	≈q
KW C08B-2	12.700	7.75	8.51	4.45	30.40	2.40	1.50	1.50	11.70	13.92	1.01	32000	1.50
KW C10B-2	15.875	9.65	10.16	5.08	35.40	2.60	1.50	1.50	14.60	16.59	1.34	44500	1.90
KW C12B-2	19.050	11.68	12.07	5.72	41.40	3.10	1.80	1.80	16.00	19.46	1.79	57800	2.35
KW C16B-221	25.400	17.02	15.88	8.28	67.30	3.40	3.70	3.00	21.00	31.88	4.21	106000	5.28
KW C20B-2	31.750	19.56	19.05	10.19	77.20	3.70	4.50	3.50	26.45	36.45	5.91	170000	7.53
KW C24B-2	38.100	25.40	25.40	14.63	101.60	4.70	6.00	4.00	33.25	48.36	11.09	280000	13.78

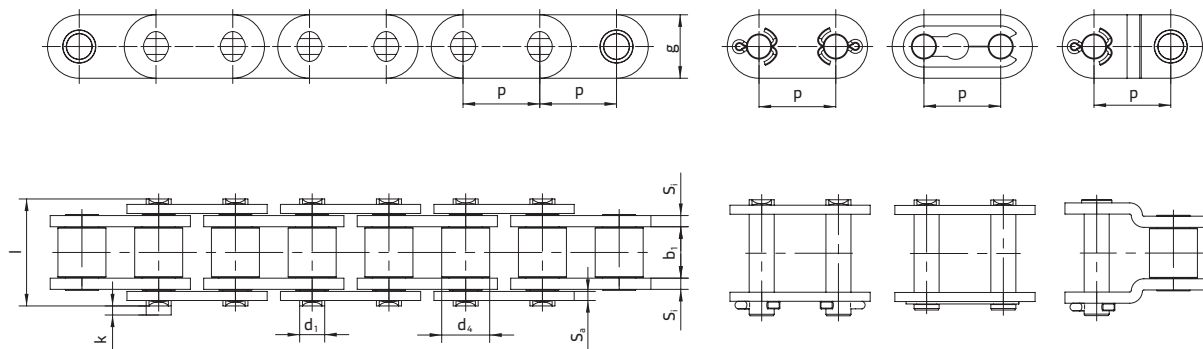
» All chain types are also available as low-maintenance (LF) versions.

» Roller chains in triplex design available upon request.

# C roller chains

## KW C Simplex – conveyor chains with straight link plates

Drawings / product data

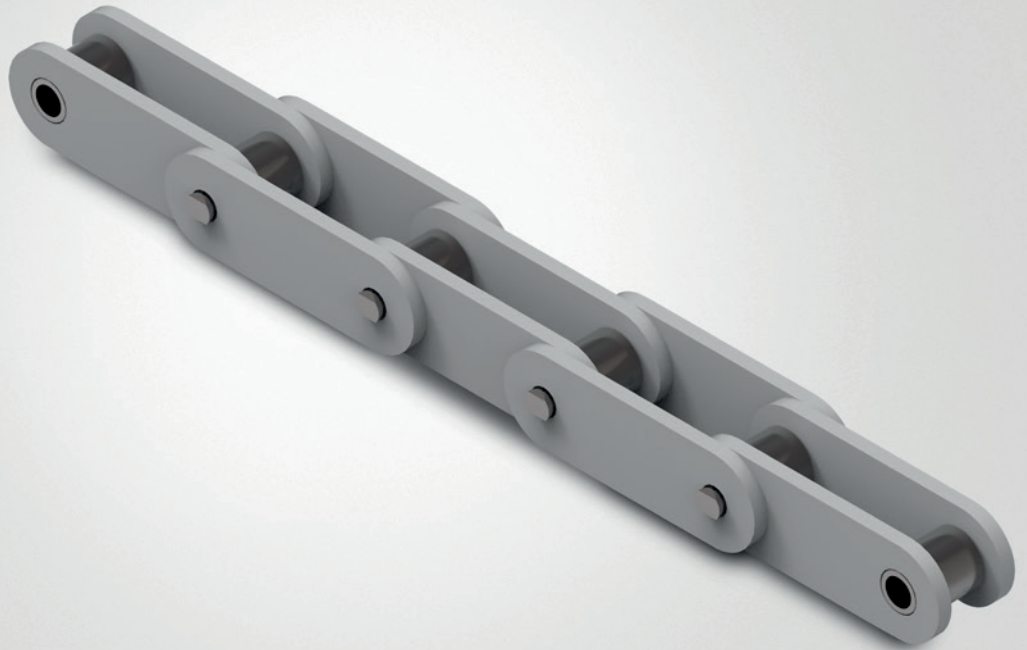


KettenWulf conveyor chains with straight link plates

KW C simplex, sizes according to American standard

ISO 606 / DIN 8187

Designation	Pitch [mm]	Min. inner width [mm]	Max. roller Ø [mm]	Max. pin Ø [mm]	Max. pin length [mm]	Max. overhang connecting pin [mm]	Inner plate thickness [mm]	Outer plate thickness [mm]	Plate height [mm]	Bearing area [cm <sup>2</sup> ]	Min. breaking load [N]	Weight [kg/m]
Chain type	p	b <sub>1</sub>	d <sub>2</sub>	d <sub>1</sub>	l	k	S <sub>1</sub>	S <sub>2</sub>	g	f	F <sub>0</sub>	≈ q
KW C50	15.875	9.40	10.14	5.08	20.4	2.10	2.00	2.00	14.60	0.69	21800	1.10
KW C60	19.050	12.57	11.91	5.94	25.3	3.30	2.40	2.40	18.00	1.05	31800	1.70
KW C60H	19.050	12.57	11.91	5.94	28.8	3.30	3.00	3.00	18.00	1.14	49000	1.80



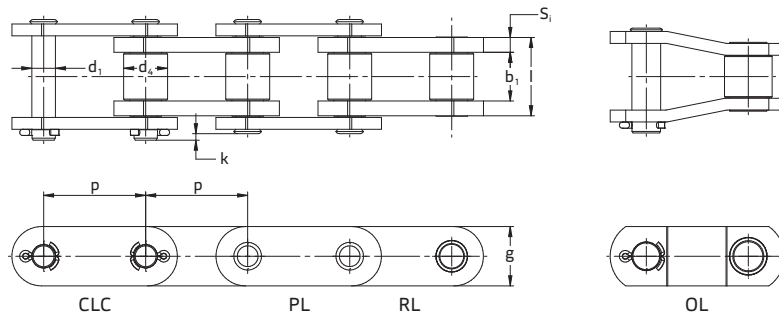
## Double Pitch (DP) roller chains

The ISO 1275-compliant KettenWulf DP “Double Pitch” roller chains are used for slow and low-speed conveyance tasks. They have the same geometric dimensions as comparable ISO 606-compliant chains, but are designed with a double pitch which allows offering them at very competitive prices. Our double pitch roller chains are available with guide and support rollers.

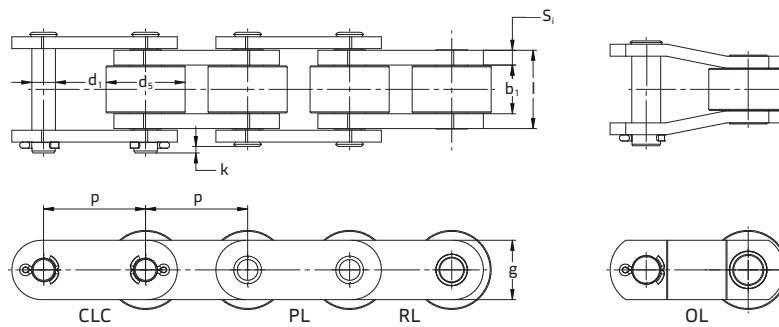
# DP roller chains

## double-pitch roller chains with straight link plates

Drawings / product data



KettenWulf double-pitch roller chains with straight link plates and protection roller



KettenWulf double-pitch roller chains with straight link plates and support roller

**KW DP simplex, sizes according to European standard**

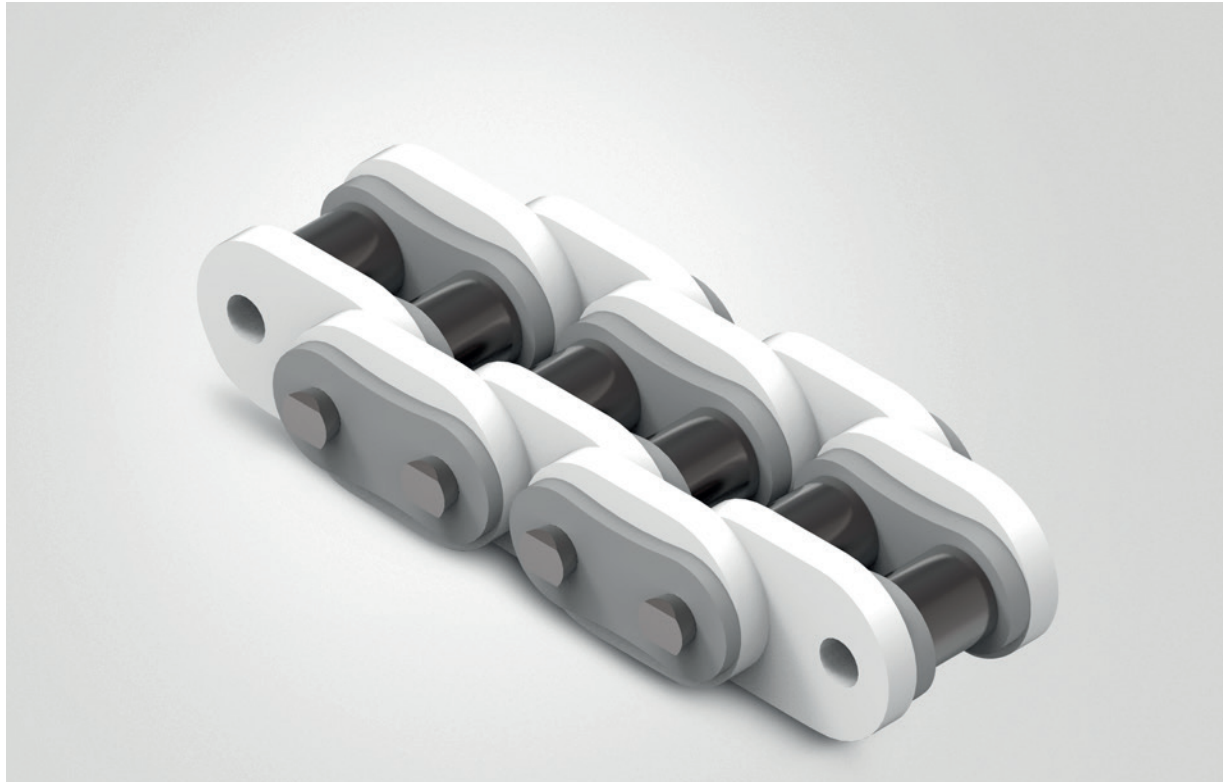
ISO 1275 / DIN 8181

Designation	Pitch [mm]	Min. inner width [mm]	Max. protection roller Ø [mm]	Max. guide roller Ø [mm]	Max. pin Ø [mm]	Max. pin length [mm]	Max. overhang connecting pin [mm]	Inner plate thickness [mm]	Outer plate thickness [mm]	Plate height [mm]	Bearing area [cm <sup>2</sup> ]	Min. breaking load [N]	Weight [kg/m]
Chain type	p	b <sub>1</sub>	d <sub>4</sub>	d <sub>3</sub>	d <sub>1</sub>	l	k	S <sub>1</sub>	S <sub>2</sub>	g	f	F <sub>B</sub>	≈q
KW C216B	50.800	17.02	15.88	-	8.28	35.40	3.40	3.70	3.00	21.00	2.10	60000	2.30

**KW DP simplex, sizes according to American standard**

ISO 1275 / DIN 8181

Chain type	p	b <sub>1</sub>	d <sub>4</sub>	d <sub>3</sub>	d <sub>1</sub>	l	k	S <sub>1</sub>	S <sub>2</sub>	g	f	F <sub>B</sub>	≈q
KW C2040	25.400	7.85	7.92	-	3.96	16.60	2.20	1.50	1.50	12.00	0.44	13900	0.48
KW C2042	25.400	7.85	-	15.88	3.96	16.60	2.20	1.50	1.50	12.00	0.44	13900	0.91
KW C2050	31.750	9.40	10.14	-	5.08	20.40	2.60	2.00	2.00	14.60	0.69	21800	0.82
KW C2052	31.750	9.40	-	19.05	5.08	20.40	2.60	2.00	2.00	14.60	0.69	21800	1.26
KW C2060H	38.100	12.58	11.91	-	5.94	28.80	3.30	3.25	3.25	18.00	1.14	31300	1.44
KW C2062H	38.100	12.58	-	22.23	5.94	28.80	3.30	3.25	3.25	18.00	1.14	31300	2.10
KW C2080H	50.800	15.75	15.88	-	7.92	36.30	3.80	4.00	4.00	23.10	1.90	55600	2.54
KW C2082H	50.800	15.75	-	28.58	7.92	36.30	3.80	4.00	4.00	23.10	1.90	55600	3.36
KW C2100H	63.500	18.90	19.05	-	9.53	43.40	3.40	4.80	4.80	30.10	2.73	87000	3.46
KW C2102H	63.500	18.90	-	39.67	9.53	43.40	3.40	4.80	4.80	30.10	2.73	87000	5.64
KW C2120H	76.200	25.23	22.23	-	11.10	53.80	3.10	5.60	5.60	36.00	4.06	125000	4.92
KW C2122H	76.200	25.23	-	44.45	11.10	53.80	3.10	5.60	5.60	36.00	4.06	125000	7.87
KW C2162H	101.600	31.80	-	57.15	14.27	64.50	4.20	6.40	6.40	48.00	6.36	223000	10.30



## BNMC roller chains

The KettenWulf BNMC roller chains are equipped with additional plastic link plates for gentle material handling.

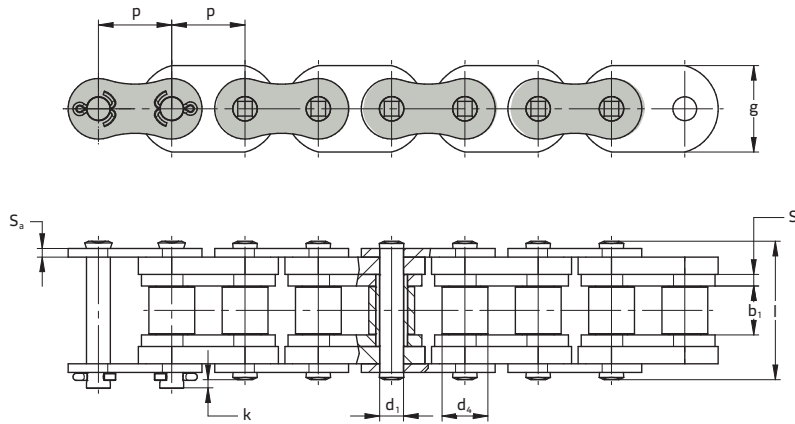
Their basic dimensions are similar to those of ISO 606-compliant roller chains. The inserted plastic link plates, however, make the chain wider. These also take the function of a guide rail replacement.



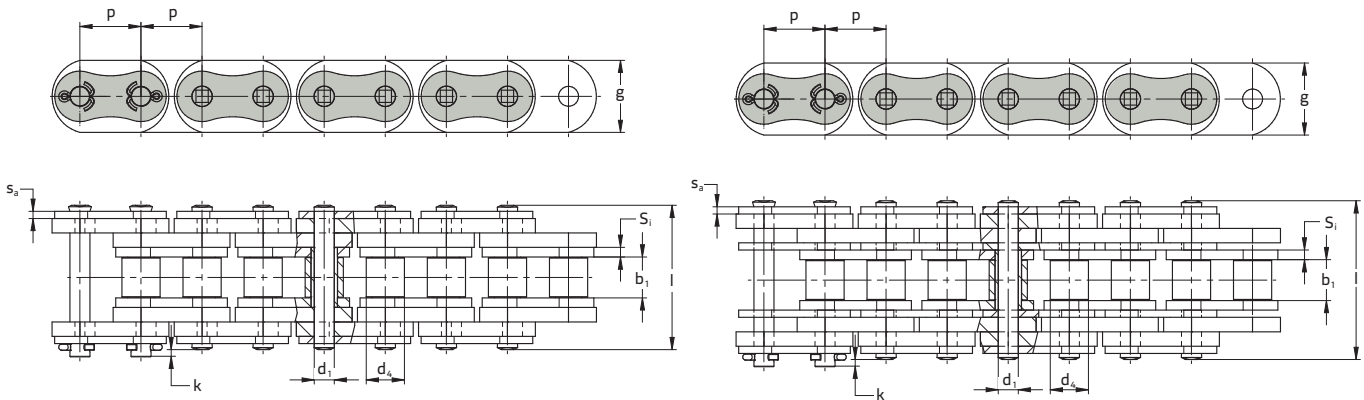
# BNMC roller chains

Chains to protect the conveyed medium with an additional plastic plate

Drawings / product data



1 KW 16BNMC07

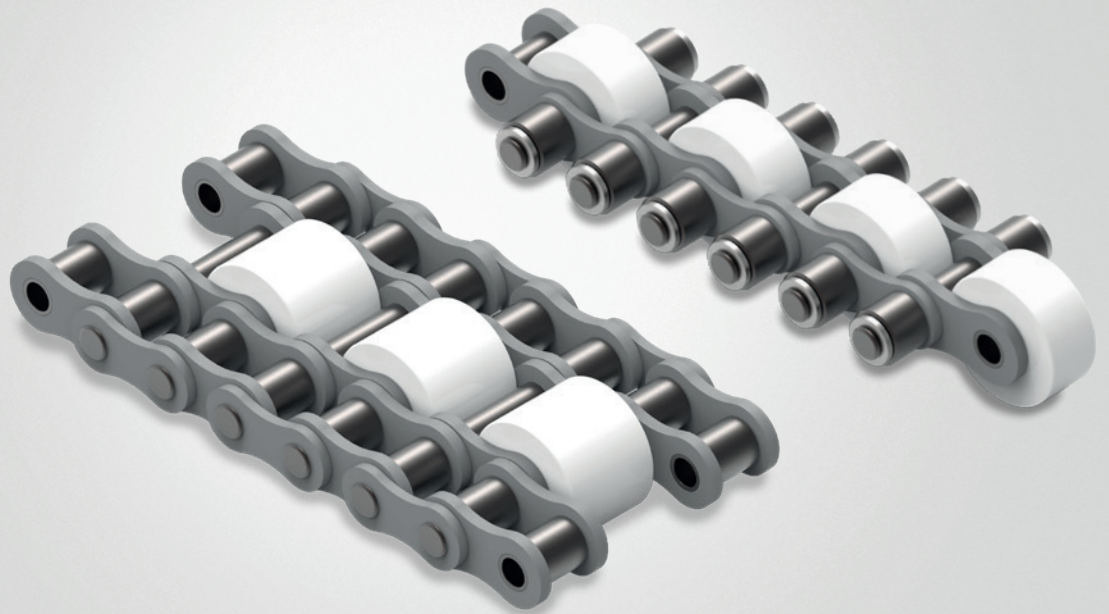


2 KW 16BNMC09

3 KW 16BNMC19

**KW BNMC (chains with additional plastic link plates)**

Figure no.	Designation	Pitch [mm]	Min. inner width [mm]	Max. roller Ø [mm]	Max. pin Ø [mm]	Max. pin length [mm]	Max. overhang connecting pin [mm]	Inner plate thickness [mm]	Outer plate thickness [mm]	Total height [mm]	Min. breaking load [N]	Weight [kg/m]
	Chain type	$p$	$b_1$	$d_e$	$d_i$	$l$	$k$	$S_i$	$S_a$	$g$	$F_b$	$\approx q$
1	KW 16BNMC07	25.400	17.02	15.88	8.28	48.00	3.00	4.00	3.00	30.00	40000	3.00
2	KW 16BNMC09	25.400	17.02	15.88	8.28	61.00	3.20	4.00	3.00	30.00	27000	3.20
3	KW 16BNMC19	25.400	17.02	15.88	8.28	67.00	3.20	4.00	3.00	30.00	60000	3.30



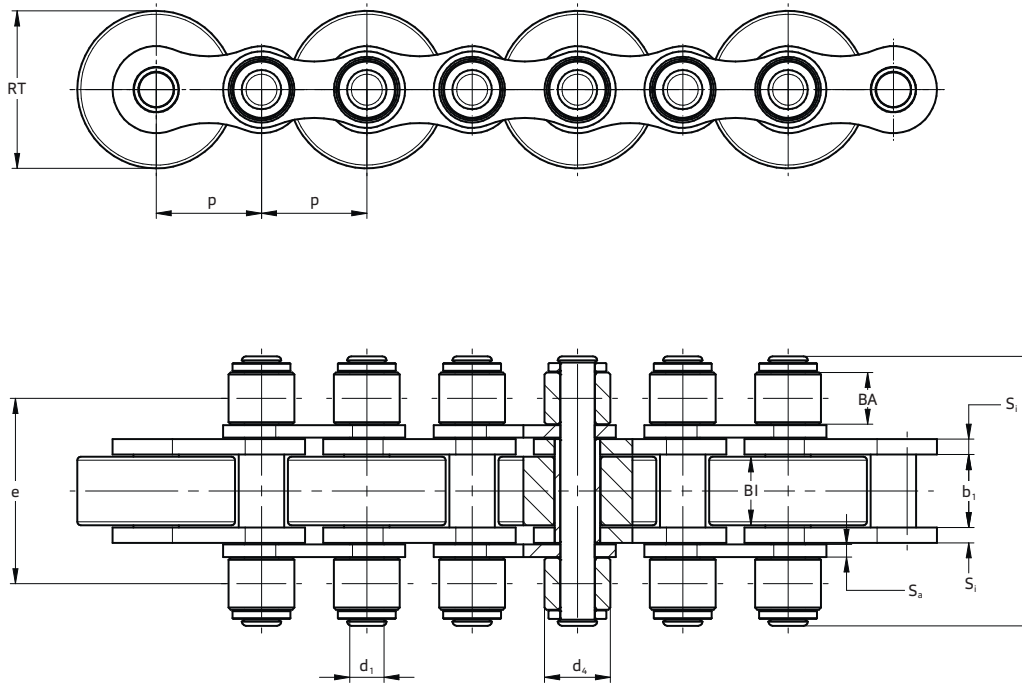
## Accumulation chains (SF)

Accumulation chains have extra steel or plastic bearing rollers on the chain to support the material during accumulation. Usually metal or plastic boxes are conveyed. They can be repositioned, taken off or temporarily stopped while the chain is in continuous operation. KettenWulf accumulation chains are available as well with LubeFree Technology (maintenance free) and with additional corrosion protection.

# Accumulation chains (SF)

## Style A35

Drawings / product data



KettenWulf accumulation chains style A35

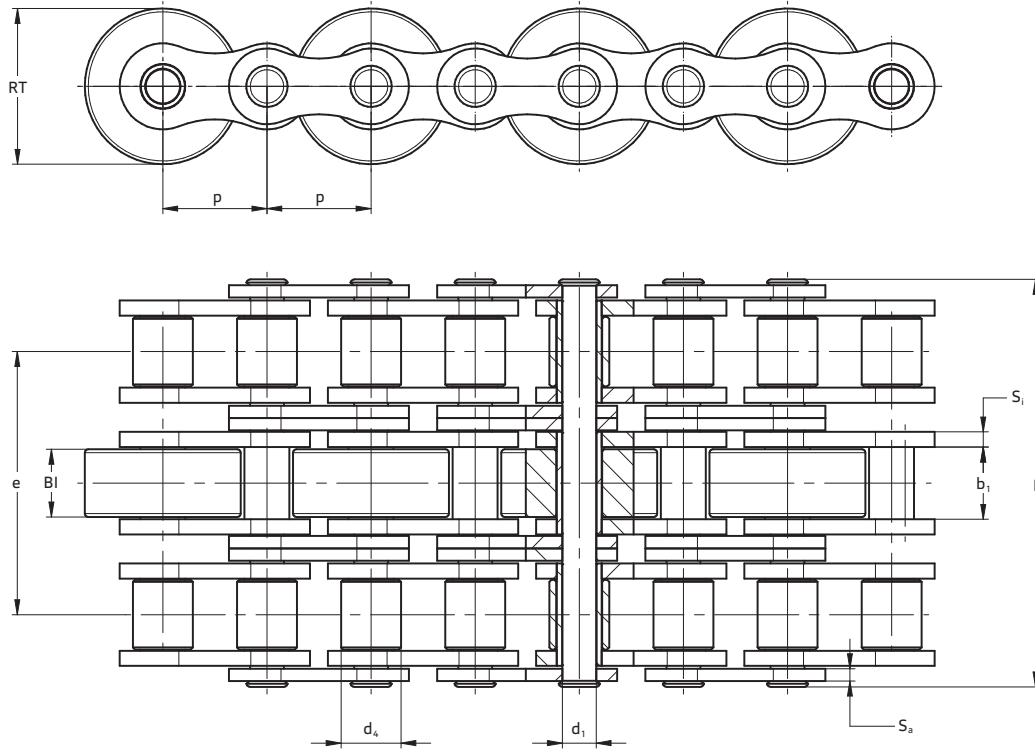
### KW SF Accumulation chains

Designation	Style	Pitch [mm]	Min. inner width [mm]	Max. roller $\varnothing$ [mm]	Max. pin $\varnothing$ [mm]	Max. bearing roller $\varnothing$	Max. pin length [mm]	Roller width [mm]	Roller width [mm]	Roller width [mm]	Roller width [mm]	Min. breaking load [N]	Weight steel roller [kg/m]	Weight plastic roller [kg/m]
		p	b <sub>1</sub>	d <sub>2</sub>	d <sub>1</sub>	RT	l	BI	BA	e	F <sub>B</sub>	≈ q	≈ q	
KW SF08B-A3516MS	A35	12.700	7.75	8.51	4.45	16.00	27.00	7.20	-	19.00	18000	1.10	0.90	
KW SF12B-A3524NS	A35	19.050	11.68	12.07	5.72	24.00	41.00	7.50	11.00	26.50	29000	-	1.90	
KW SF12B-A3524MS	A35	19.050	11.68	12.07	5.72	24.00	44.00	9.00	11.00	28.50	29000	-	2.00	
KW SF12B-A3524LS	A35	19.050	11.68	12.07	5.72	24.00	48.00	11.50	11.00	31.50	29000	-	2.10	
KW SF12B-A3526NS	A35	19.050	11.68	12.07	5.72	26.00	41.00	7.50	11.00	26.50	29000	2.80	2.00	
KW SF12B-A3526MS	A35	19.050	11.68	12.07	5.72	26.00	44.00	9.00	11.00	28.50	29000	2.90	2.00	
KW SF12B-A3526LS	A35	19.050	11.68	12.07	5.72	26.00	48.00	11.50	11.00	31.50	29000	2.90	2.20	
KW SF12B-A3528NS	A35	19.050	11.68	12.07	5.72	28.00	41.00	7.50	11.00	26.50	29000	3.00	2.30	
KW SF12B-A3528MS	A35	19.050	11.68	12.07	5.72	28.00	44.00	9.00	11.00	28.50	29000	3.20	2.40	
KW SF12B-A3528LS	A35	19.050	11.68	12.07	5.72	28.00	48.00	11.50	11.00	31.50	29000	3.50	2.40	
KW SF16B-A35385LS	A35	25.400	17.02	15.88	8.28	38.50	65.00	16.50	12.50	44.90	60000	6.50	4.70	

# Accumulation chains (SF)

## Style A50

Drawings / product data



KettenWulf accumulation chains style A50

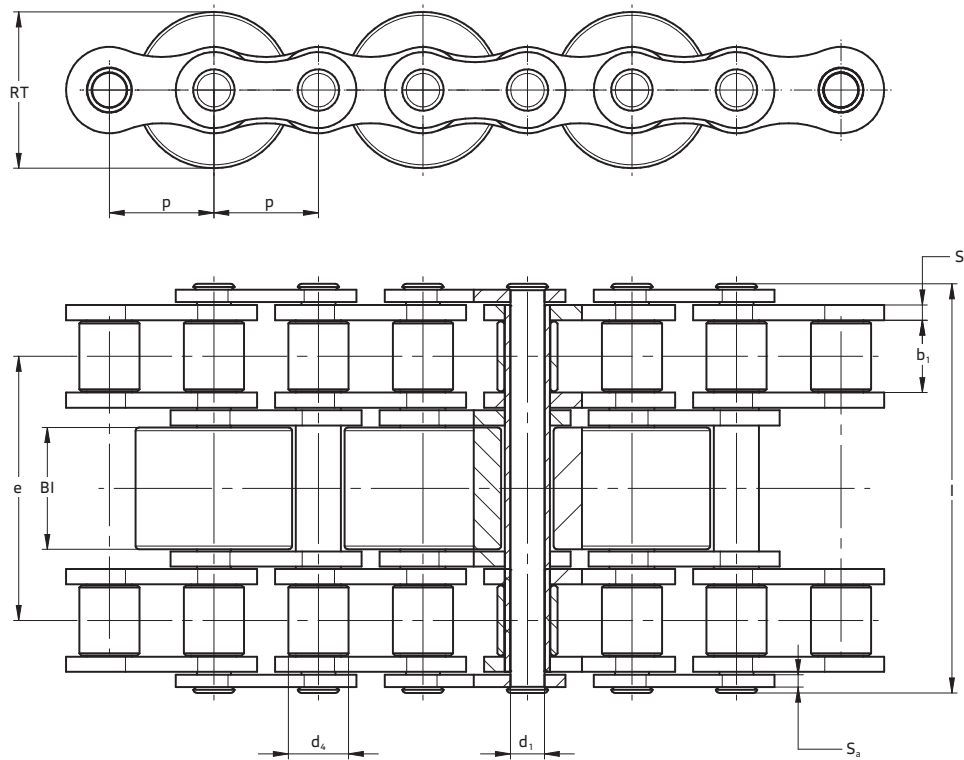
### KW SF Accumulation chains

Designation	Style	Pitch [mm]	Min. inner width [mm]	Max. roller $\varnothing$	Max. pin $\varnothing$ [mm]	Max. bearing roller $\varnothing$ [mm]	Max. pin length [mm]	Roller width [mm]	Traverse pitch [mm]	Min. breaking load	Weight steel roller [kg/m]
		p	b <sub>1</sub>	d <sub>4</sub>	d <sub>1</sub>	RT	l	Bl	e	F <sub>B</sub>	≈q
KW SF12B-A5024S	A50	19.050	11.68	12.07	5.72	24.00	61.00	11.00	38.90	90000	3.80
KW SF12B-A5026S	A50	19.050	11.68	12.07	5.72	26.00	61.00	11.00	38.90	90000	3.90
KW SF12B-A5028S	A50	19.050	11.68	12.07	5.72	28.00	61.00	11.00	38.90	90000	4.00

# Accumulation chains (SF)

## Style A60

Drawings / product data

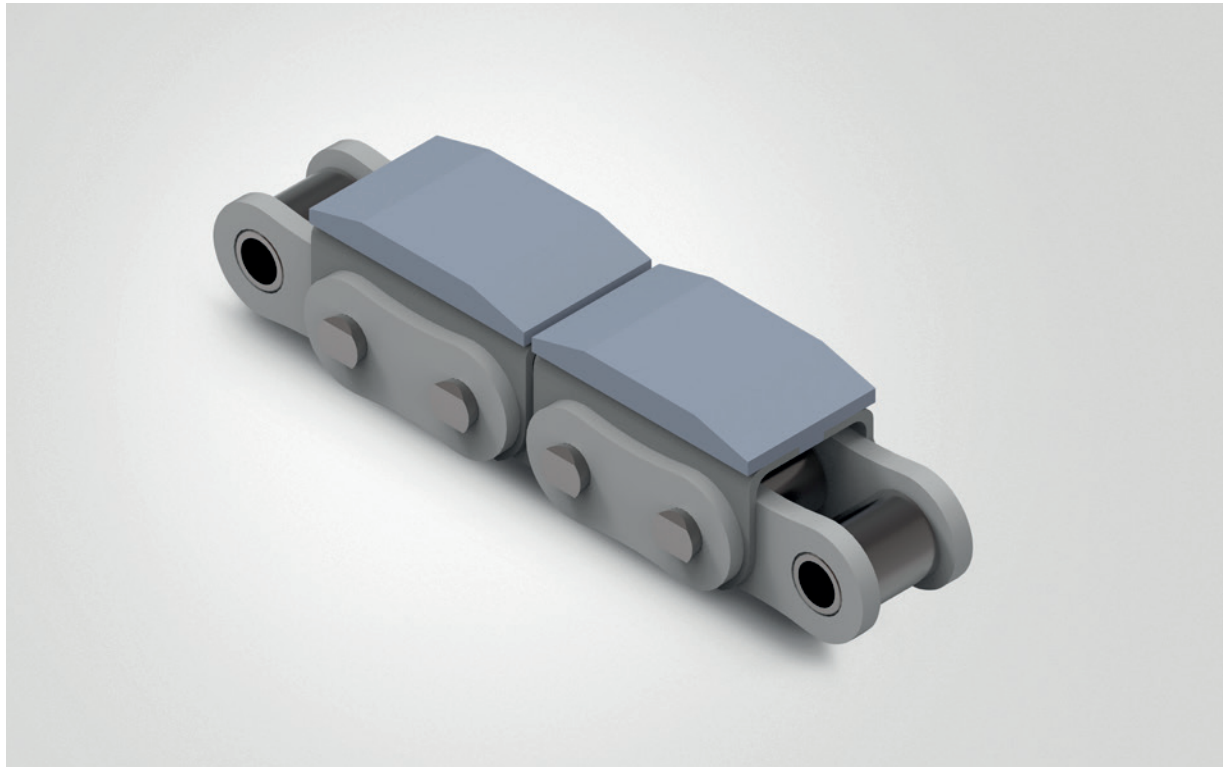


KettenWulf accumulation chains style A60

### KW SF Accumulation chains

Designation	Style	Pitch [mm]	Min. inner width [mm]	Max. roller $\varnothing$	Max. pin $\varnothing$ [mm]	Max. bearing roller $\varnothing$ [mm]	Max. pin length [mm]	Roller width [mm]	Traverse pitch [mm]	Min. breaking load	Weight steel roller [kg/m]
Kettentyp		p	b <sub>i</sub>	d <sub>e</sub>	d <sub>i</sub>	RT	L1/L2	BI	e	F <sub>B</sub>	≈ q
KW SF08B-A6018S	A60	12.700	7.75	8.51	4.45	18.00	44.50/45.80	12.50	27.84	36000	2.60
KW SF12B-A6024S	A60	19.050	11.68	12.07	5.72	24.00	61.00/63.00	17.50	38.90	60000	4.40
KW SF12B-A6026S	A60	19.050	11.68	12.07	5.72	26.00	61.00/63.00	17.50	38.90	60000	4.50
KW SF12B-A6028S	A60	19.050	11.68	12.07	5.72	28.00	61.00/63.00	17.50	38.90	60000	4.60
KW SF16B-A6035S	A60	25.400	17.02	15.88	8.28	35.00	99.40/103.00	24.50	31.88	125000	10.30
KW SF24B-A6050S	A60	38.100	25.40	14.63	14.63	50.00	150.20/155.00	46.00	48.39	350000	25.50





## Elastomer profile chains

The CP roller chain is based on the standard roller chain with straight link plates. An elastomer profile available in different heights and shapes is vulcanised onto this chain for picking up the conveyed material.

From stock we can deliver chains with elastomer profiles made of nitrile butadiene rubber (NBR) in shore A hardness grade of 75 ( $\pm 5$ ) in grey colour. In addition to that, we can deliver chains with elastomers made of NR or PUR in other colours as well, upon request. We also offer the elastomers in different grades of shore hardness. Feel free to contact us to request the specifications you need.

## CP chains

### Chains to protect the conveyed medium with elastomer profile

#### Default material properties

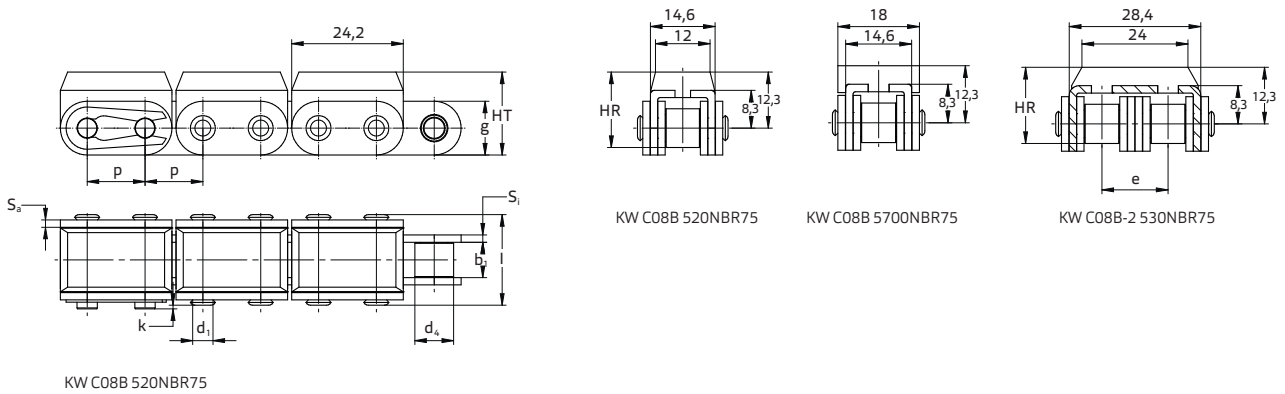
Roller chains with elastomer profiles			
	NR	NBR	PUR
Default values	Natural rubber	Nitrile butadiene rubber	Polyurethanes
Colour	Ivory	Light grey	Orange
Shore hardness A	65 ±5	75 ±5	85 ±5
Operating temperatures	-50 to +90°C	-40 to +130 °C	-35 to +80 °C
Abrasion resistance	+++	+++	++++
Tear resistance	+++	++	++++
Resistance to ageing	++	++	++++
Resistance to petrol	0	++++	+++
Resistance to oil and grease	0	++++	+++
Resistance to hot water and steam	++	++	0

++++ excellent    +++ very good    ++ good    + poor    0 inadequate

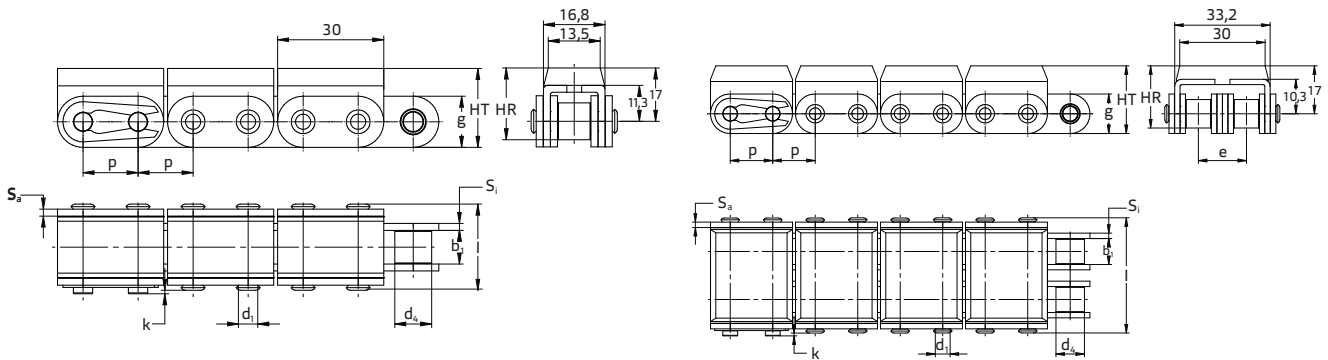
## CP chains

### Chains to protect the conveyed medium with elastomer profile

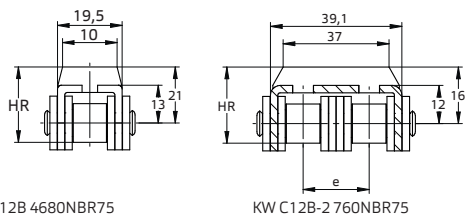
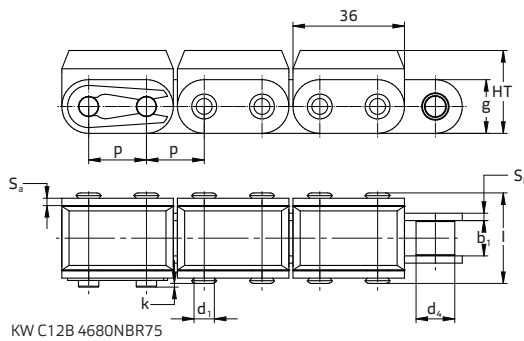
#### Drawings



#### 1 KW C08B in different profiles

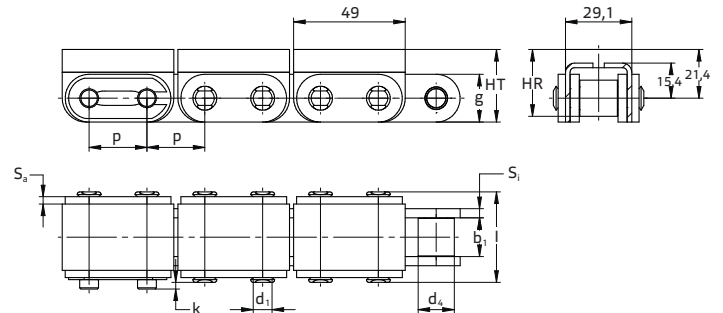


#### 2 KW C10B-5200NBR75



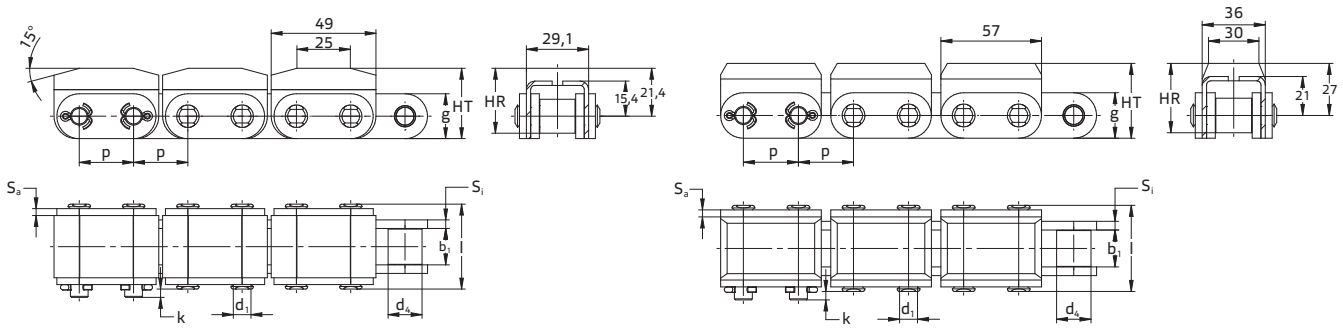
#### 4 KW C12B in different profiles

#### 3 KW C10B-2 3190NBR75



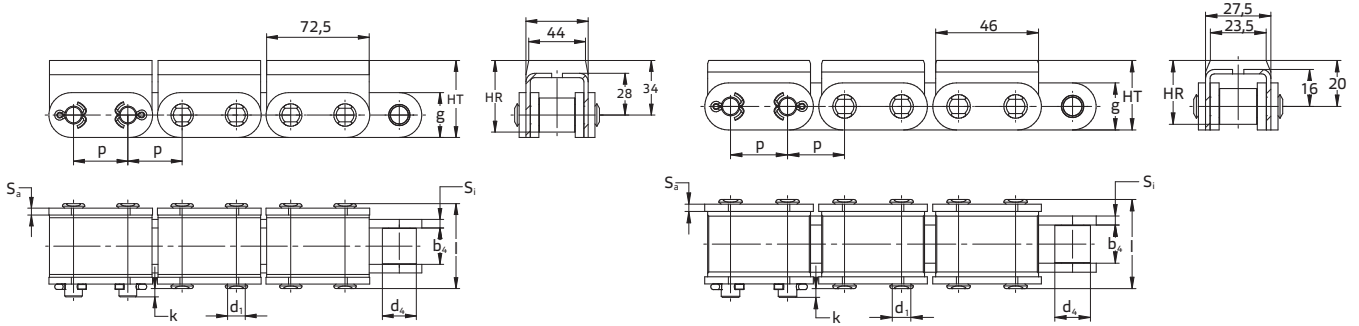
#### 5 KW C16B 1310NBR75

Drawings / product data



6 KW C16B 6580NBR75

7 KW C20B 2160NBR75



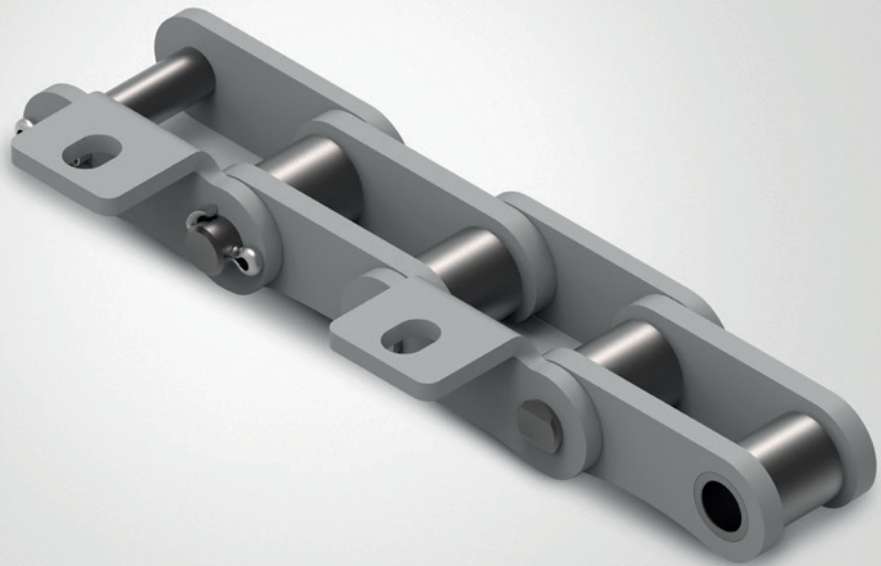
8 KW C24B 835NBR75

9 KW C80 570NBR75

KW CP (elastomer profile chains)

Figure no.	Designation	Pitch [mm]	Min. inner width [mm]	Max. roller Ø [mm]	Max. pin Ø [mm]	Max. pin length [mm]	Max. overhang connecting pin [mm]	Inner plate thickness [mm]	Outer plate thickness [mm]	Total height [mm]	Roller bottom edge - top edge profile [mm]	Transverse pitch [mm]	Min. breaking load [N]	Weight [kg/m]
	Chain type	p	b <sub>i</sub>	d <sub>k</sub>	d <sub>l</sub>	l	k	S <sub>i</sub>	S <sub>o</sub>	H <sub>T</sub>	H <sub>R</sub>	e	F <sub>B</sub>	≈q
1	KW C08B 520NBR75	12.700	7.75	8.51	4.45	20.00	1.50	1.60	1.60	18.20	16.60	-	18000	1.40
1	KW C08B 5700NBR75	12.700	7.75	8.51	4.45	20.00	1.50	1.60	1.60	18.20	16.60	-	18000	1.33
1	KW C08B-2 530NBR75	12.700	7.75	8.51	4.45	34.30	1.20	1.60	1.60	18.20	16.60	13.92	32000	2.49
2	KW C10B 5200NBR75	15.875	9.65	10.16	5.08	23.20	1.50	1.70	1.70	24.30	22.10	-	26000	-
	KW C10B-2 5200NBR75	15.875	9.65	10.16	5.08	39.70	1.50	1.70	1.70	24.30	22.10	-	52000	-
3	KW C10B-2 3190NBR75	15.875	9.65	10.16	5.08	39.70	1.50	1.70	1.70	24.30	22.10	-	52000	-
4	KW C12B 4680NBR75	19.050	11.68	12.07	5.72	26.50	1.50	1.88	1.88	29.00	27.00	-	29000	2.15
4	KW C12B-2 760NBR75	19.050	11.68	12.07	5.72	46.00	1.50	1.88	1.88	24.00	22.00	19.46	57800	3.48
5	KW C16B 1310NBR75	25.400	17.02	15.88	8.28	39.70	1.30	4.00	3.00	32.00	29.30	-	60000	4.15
6	KW C16B 6580NBR75	25.400	17.02	15.88	8.28	39.70	1.30	4.00	3.00	32.00	29.30	-	70600	4.15
7	KW C20B 2160NBR75	31.750	19.58	19.05	10.19	48.50	4.00	4.50	3.50	40.15	36.53	-	95000	6.73
8	KW C24B 835NBR75	38.100	25.40	25.40	14.63	61.60	4.40	6.00	4.70	50.60	46.70	-	160000	11.60
	Chain type	p	b <sub>i</sub>	d <sub>k</sub>	d <sub>l</sub>	l	k	S <sub>i</sub>	S <sub>o</sub>	H <sub>T</sub>	H <sub>R</sub>	e	F <sub>B</sub>	≈q
9	KW C80 570NBR75	25.400	15.75	15.88	7.92	38.00	1.40	3.25	3.25	32.00	28.00	-	73500	5.34

» Upon request, we can deliver the materials in higher grades of shore hardness.



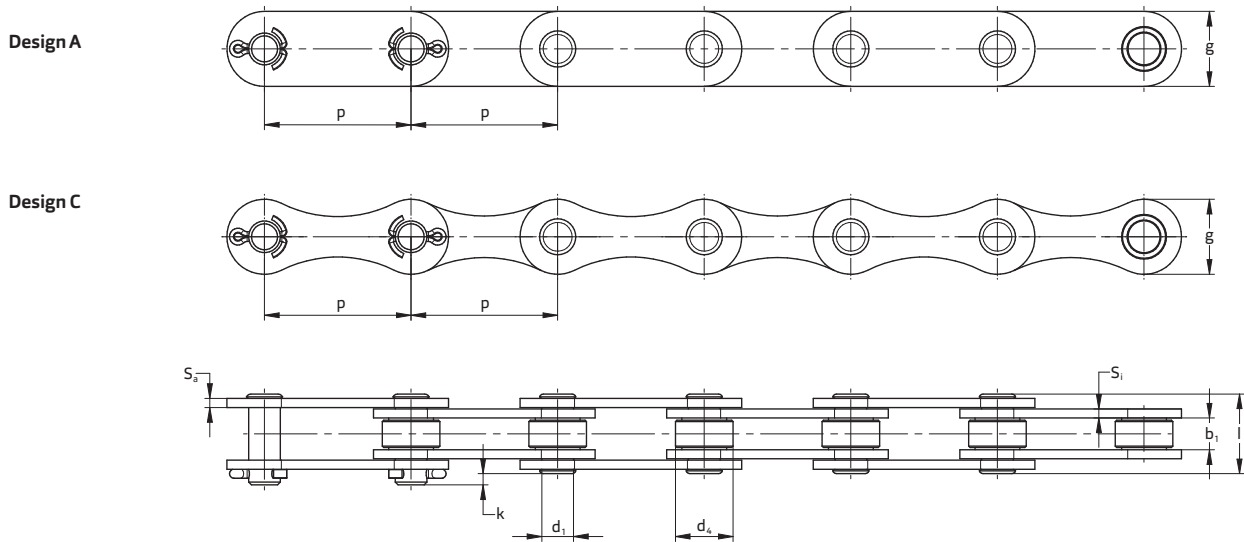
## S agricultural machinery chains

The KettenWulf S agricultural machinery chains are manufactured in accordance with ISO 487 and KW factory standard. Due to the quenched and tempered link plates the breaking load of the chains is above standard. The chains are available in a steel version or a galvanised version. Upon request, we can deliver type A-1 and type K-1 attachments for the agricultural machinery chains.



# S agricultural machinery chains

## Drawings / product data



## KettenWulf agriculture machinery chains

### KW S agricultural machinery chains

Designation	Pitch [mm]	Min. inner width [mm]	Max. protection roller $\varnothing$ [mm]	Max. pin $\varnothing$ [mm]	Max. pin length [mm]	Max. overhang connecting pin [mm]	Inner plate thickness [mm]	Outer plate thickness [mm]	Plate height [mm]	Bearing area [cm <sup>2</sup> ]	Min. breaking load [N]	Weight [kg/m]	Designs
Chain type	p	b <sub>1</sub>	d <sub>r</sub>	d <sub>i</sub>	l	k	S <sub>i</sub>	S <sub>o</sub>	g	f	F <sub>b</sub>	≈q	
KW S45ZP*	41.400	22.23	15.24	5.72	37.30	1.90	2.70	2.70	17.20	1.60	17800	1.66	A
KW S52ZP*	38.100	22.23	15.24	5.72	37.30	1.90	2.70	2.70	17.20	1.60	32000	1.68	A
KW S55ZP*	41.400	22.23	17.78	5.72	37.70	2.70	2.80	2.80	17.30	1.60	17800	1.80	A
KW 384R2P	38.400	19.05	15.88	6.92	33.40	2.80	2.50	2.50	17.20	1.68	33000	1.70	C
KW 384RS2P	38.400	18.00	15.88	6.92	33.40	3.10	3.00	3.00	17.20	1.75	40000	1.80	C
KW 384SK2P	38.400	19.05	15.88	8.28	35.60	3.20	3.00	3.00	20.50	2.10	42100	2.10	C

\* zinc plated



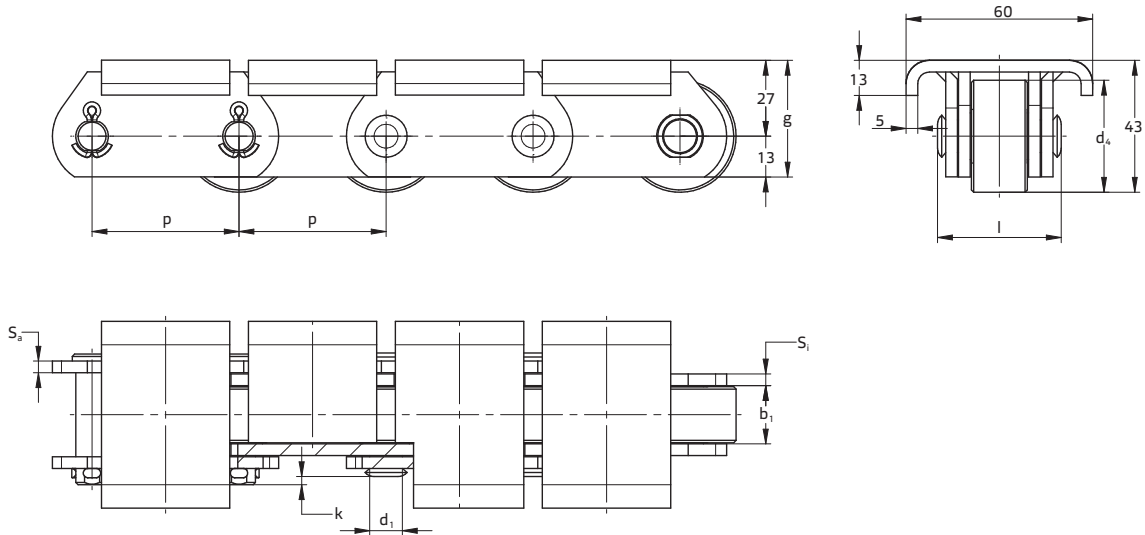
## Deep link chains

These special-purpose chains were developed especially for the wood-processing industry but are increasingly used in other industries due to their wide range of possible applications.

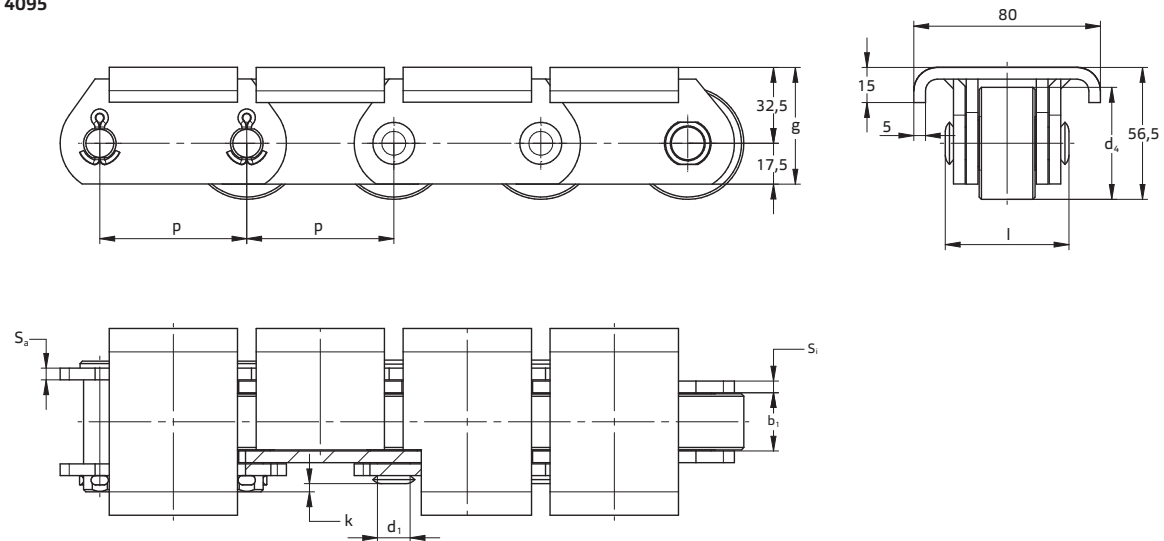
# Deep link chains

Chains to protect the conveyed medium for the wood-processing industry

Drawings / product data



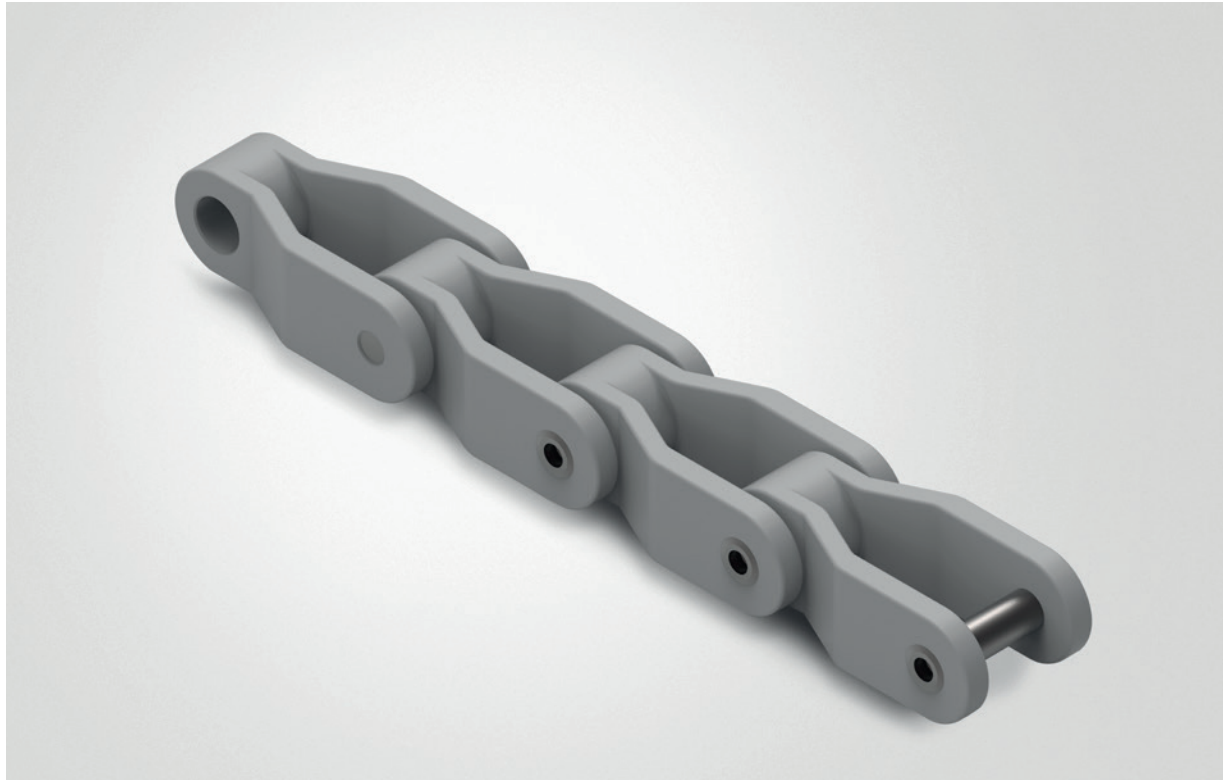
1 KW 4095



2 KW 4098

KW deep link chains

Figure no.	Designation	Pitch [mm]	Min. inner width [mm]	Max. bush or roller Ø [mm]	Max. pin Ø [mm]	Max. pin length [mm]	Max. connecting pin overhang [mm]	Plate thickness [mm]	Plate height [mm]	Bearing area [cm <sup>2</sup> ]	Min. breaking load [N]	Weight [kg/m]
	Chain type	p	b <sub>i</sub>	d <sub>4</sub>	d <sub>1</sub>	l	k	S <sub>i</sub> /S <sub>a</sub>	g	f	F <sub>B</sub>	≈q
1	KW 4095	40.000	18.00	32.00	10.00	36.00	4.00	3.00	40.00	2.40	40000	7.40
	KW 4096	50.000	15.00	31.00	10.00	36.00	4.00	4.00	30.00	4.90	50000	6.50
2	KW 4098	63.000	25.00	48.00	14.00	53.00	6.00	5.00	50.00	4.90	140000	14.00



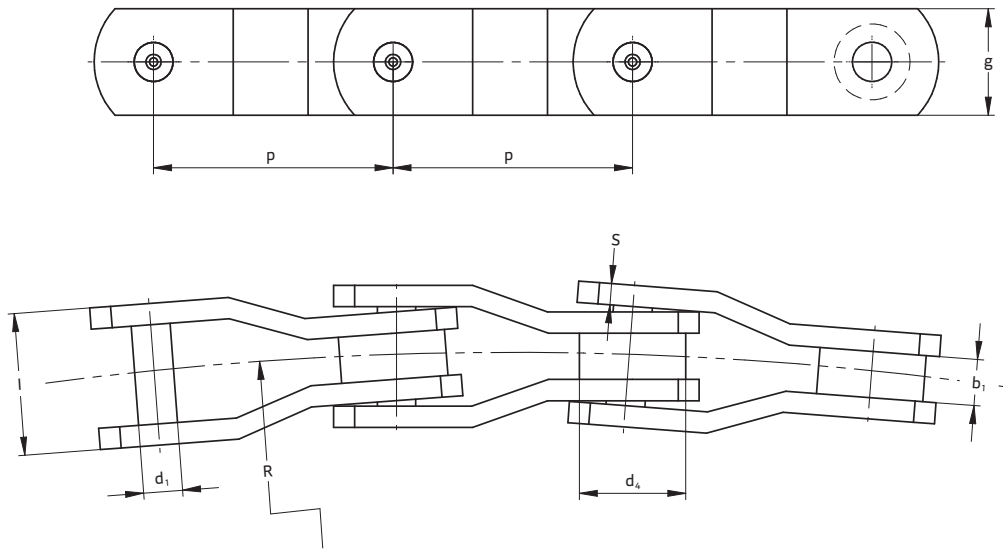
## Crate Conveyor (CC) side-flexing conveyor chain

The KettenWulf CC “Crate Conveyor” side-flexing conveyor chain consists of cranked cast-steel link plates. The connecting pins are designed as threaded pin bolts which makes them easy to assemble. Because it can be used in curved conveyor belts, the CC chain is commonly used for transporting boxes.

# CC chains

## Side-flexing conveyor chain

Drawings / product data

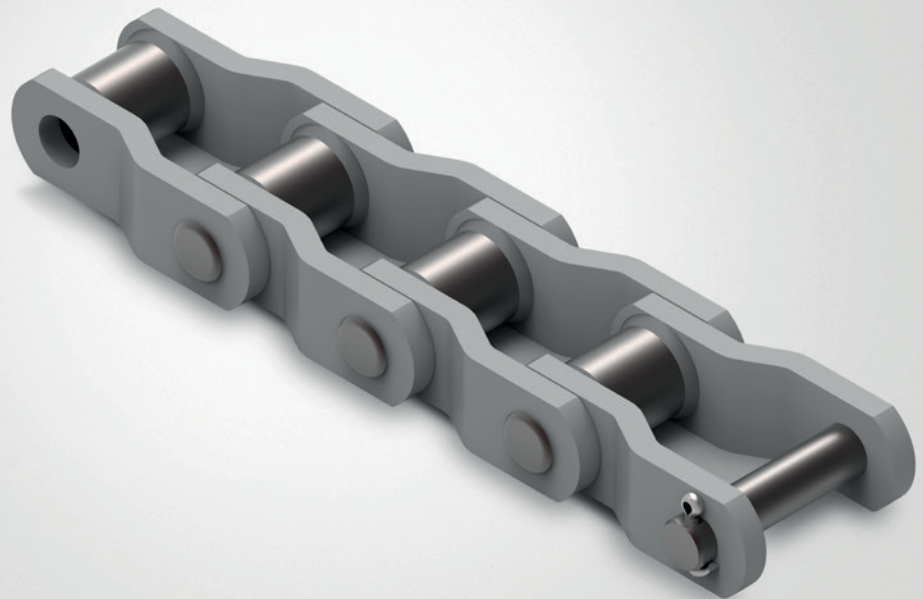


KettenWulf side-flexing conveyor chains with cranked cast-steel plate links

KW CC chains

Designation	Pitch [mm]	Min. inner width [mm]	Max. protection roller $\varnothing$ [mm]	Max. pin $\varnothing$ [mm]	Max. pin length [mm]	Inner plate thickness [mm]	Plate height [mm]	Total width [mm]	Min. radius [mm]	Max. working load [N]	Min. breaking load [N]	Weight [kg/m]
Chain type	p	b <sub>1</sub>	d <sub>4</sub>	d <sub>1</sub>	l	S	g		R	F <sub>w</sub>	F <sub>b</sub>	≈ q
KW CC600	63.500	13.00	30.00	11.00	42.50	6.00	30.00	43.50	500.00	6000	65000	5.00





## Welded Steel Chain (WSC)

The product line of KettenWulf welded steel chains is split into the “narrow” series and the “wide” series, as well as a “reinforced clinker” series.

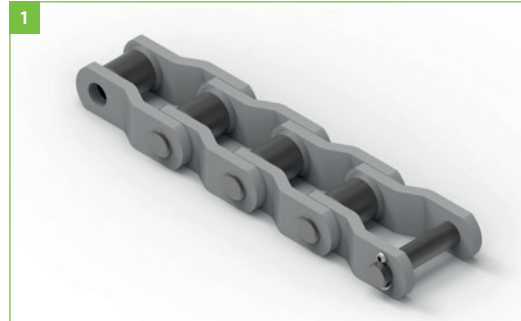
KettenWulf welded steel chains are manufactured for many different industrial sectors, including the transport of bulk material and wood chips. They are made from specially alloyed heat-treated steel using the latest welding and heat treatment processes. The combination of specially alloyed heat-treated steel, state-of-the-art welding techniques, controlled tempering processes, mechanical high-precision finishing and a careful assembly process ensures high fatigue strength and a long service life.

Upon request, we also offer selectively induction-hardened link plates or hardfacing for enhanced wear resistance of the sliding surface. Stainless welded steel chains can be made of SUS 316L plate material and 17-4 PH pin and bush material.

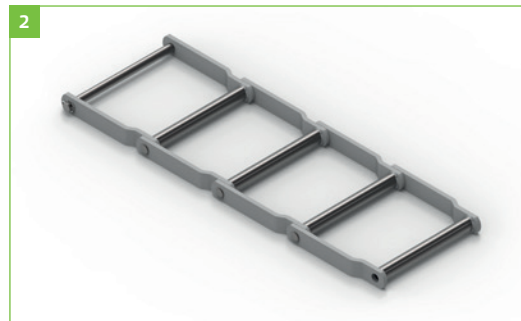
Hybrid chains with link plates made of heat-treated steel and link components made of stainless tempered steel are available upon request. Chains of the “wide series” have formed bushes for a high conveying capacity.

## Specific designs for Welded steel chains

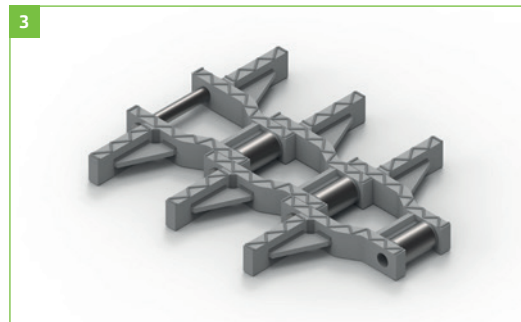
**Figure 1:**  
"Narrow" series  
WR/WH/WHX



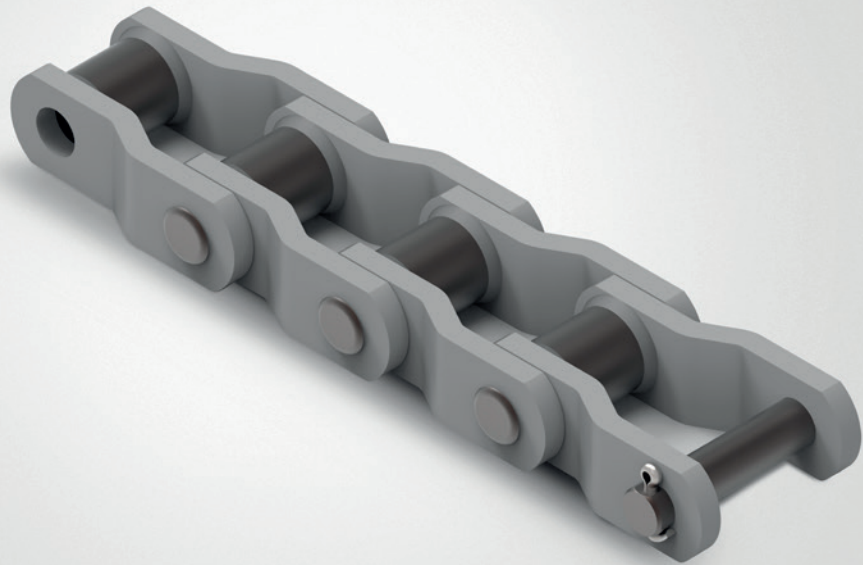
**Figure 2:**  
"Wide" series  
WDH/WDR



**Figure 3:**  
"Reinforced clinker" series  
WHX HD



» Different angles and lug types are available upon request.



## Welded steel chains (WSC) “narrow” series WR/WH/WHX

The KettenWulf “narrow” series of welded chains is widely used for transport applications in the timber and bulk material handling industries as well as in other areas with high stress on the chains. The narrow series is available in three versions. Their designations reflect the heat treatment used for producing their components.

### **WR series:**

The pins of the KettenWulf WR series are through hardened to ensure optimal wear resistance. Link plates and bushes are untreated.

### **WH series:**

All components of the KettenWulf WH series are fully heat treated. This improves the chains wear resistance and increases its breaking load and fatigue strength.

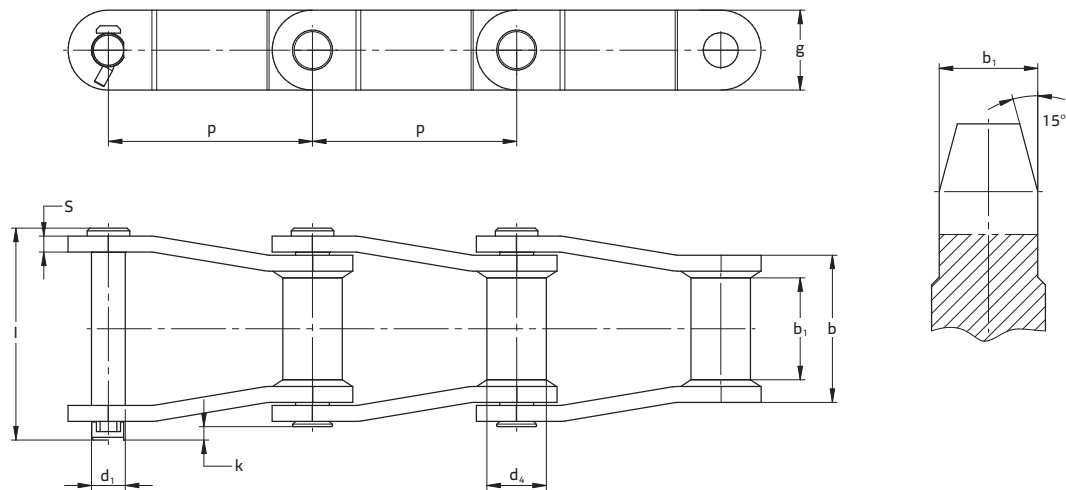
### **WHX series:**

Certain parts of the pins of the WHX series are induction-hardened in addition to the general treatment. The high strength induction-hardened section ensures maximum wear resistance while the tempered section ensures that the pin retains its optimal toughness and shock resistance. The link plates and bushes of this chain are heat-treated just like the components of the WH series.

# WSC chains

## WR series

Drawings / product data



### KettenWulf welded steel chains – narrow series

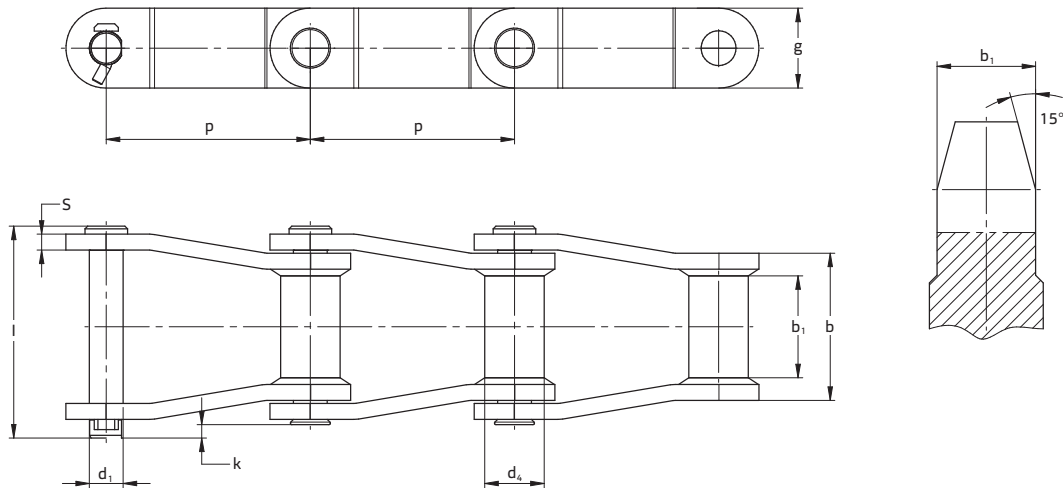
#### KW WR series

Designation	Pitch [mm]	Min. inner width [mm]	Max. inner width [mm]	Max. bush [mm]	Max. pin Ø [mm]	Max. pin length [mm]	Max. overhang connecting pin [mm]	Plate thickness [mm]	Plate height [mm]	Min. breaking load [N]	Max. working load [N]	Weight [kg/m]
Chain type	p	b <sub>1</sub>	b	d <sub>4</sub>	d <sub>1</sub>	l	k	S	g	F <sub>B</sub>	≈ q	
KW WR78	66.270	28.40	51.00	22.23	12.70	75.80	3.20	6.40	28.60	106800	10500	6.00
KW DWR78	66.270	28.40	51.00	21.40	12.70	75.80	3.20	6.40	31.80	125000	12100	6.50
KW WR78B	66.270	28.40	51.00	27.00	12.70	75.80	3.20	6.40	31.80	125000	12100	7.00
KW WSR78	66.270	20.00	41.30	21.30	12.70	66.10	3.10	6.40	25.40	85300	8300	5.20
KW WR78HD	66.950	25.40	51.20	25.40	14.27	85.50	5.10	9.50	31.80	133400	14700	9.50
KW WR82	78.100	31.80	57.40	25.40	14.27	83.50	3.50	6.40	31.80	133400	14700	6.90
KW WR82HD	78.100	28.60	60.80	31.75	19.05	97.30	4.30	9.50	38.10	215000	20500	12.70
KW WR124	101.600	38.10	71.50	31.80	19.05	108.00	4.00	9.50	38.10	204000	20500	11.60
KW WR124HD	103.200	38.10	76.30	41.28	25.40	123.70	4.90	12.70	50.80	378000	46500	21.40
KW WR111	120.900	50.80	85.60	31.80	19.05	122.70	3.90	9.50	44.50	270000	32500	13.00
KW WR106	152.400	38.10	71.50	31.80	19.05	108.00	4.00	9.50	38.10	204000	20500	9.70
KW WR110	152.400	44.50	76.50	31.80	19.05	114.00	5.20	9.50	38.10	204000	20500	9.60
KW WR132	153.670	69.85	111.60	44.50	25.40	159.00	4.40	12.70	50.80	345000	42500	21.10
KW WR150	153.670	69.85	111.60	44.50	25.40	159.00	4.40	12.70	63.50	345000	42500	25.00

# WSC chains

## WH series

Drawings / product data



### KettenWulf welded steel chains – narrow series

#### KW WH series

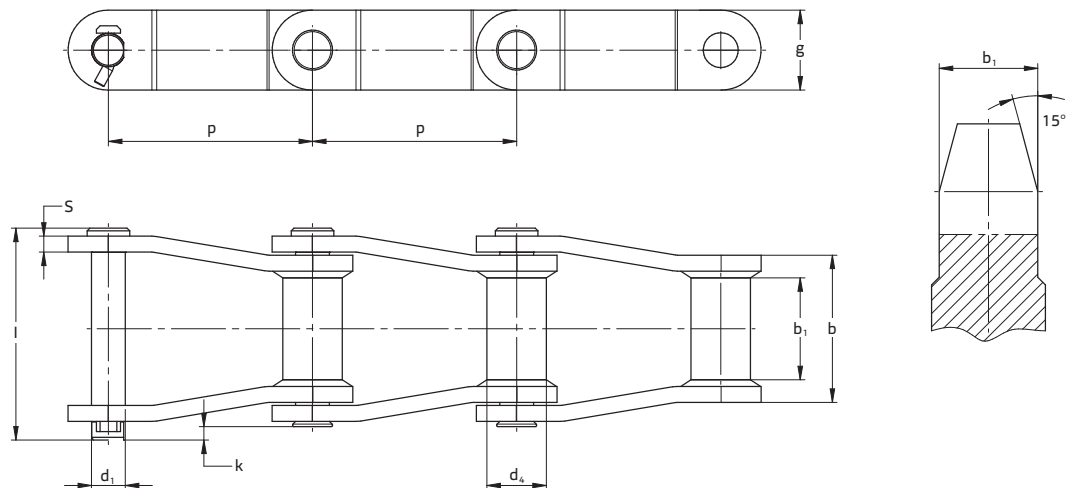
Designation	Pitch [mm]	Min. inner width [mm]	Max. inner width [mm]	Max. bush $\varnothing$ [mm]	Max. pin $\varnothing$ [mm]	Max. pin length [mm]	Max. overhang connecting pin [mm]	Plate thickness [mm]	Plate height [mm]	Min. breaking load [N]	Max. working load [N]	Weight [kg/m]
Chain type	p	b <sub>1</sub>	b	d <sub>4</sub>	d <sub>1</sub>	l	k	S	g	F <sub>B</sub>	≈q	
KW WH78	66.270	28.40	51.00	22.23	12.70	75.80	3.20	6.40	28.60	160000	15600	6.00
KW WH78B	66.270	28.40	51.00	27.00	12.70	75.80	3.20	6.40	31.80	160000	15600	7.00
KW WH78HD	66.950	25.40	51.20	25.40	14.27	85.50	5.10	9.50	31.80	200000	19600	9.40
KW WH82	78.100	31.80	57.40	27.00	14.27	83.50	3.50	6.40	31.80	200000	19600	7.20
KW WH82HD	78.100	28.60	60.80	31.75	19.05	97.30	4.30	9.50	38.10	320000	32700	12.80
KW WH9103HD	78.100	28.60	57.90	31.75	18.95	91.90	4.90	9.50	38.10	320000	32900	12.00
KW WH124	101.600	38.10	71.50	31.80	19.05	108.00	4.00	9.50	38.10	320000	32700	11.50
KW WH124HD	103.200	38.10	76.30	41.28	25.40	123.70	4.90	12.70	50.80	540000	66800	21.30
KW WH111	120.900	50.80	85.60	31.80	19.05	122.70	3.90	9.50	44.50	320000	39500	13.00
KW WH720	152.400	28.50	55.00	32.00	19.05	94.00	5.00	10.00	40.00	350000	35800	9.70
KW WH106	152.400	38.10	71.50	31.80	19.05	108.00	4.00	9.50	38.10	320000	32700	9.60
KW WH110	152.400	44.50	76.50	31.80	19.05	114.00	5.20	9.50	38.10	320000	32700	9.60
KW WH132HD	153.670	69.85	119.03	44.50	25.40	173.70	5.70	15.90	50.80	540000	69300	24.80



# WSC chains

## WHX series

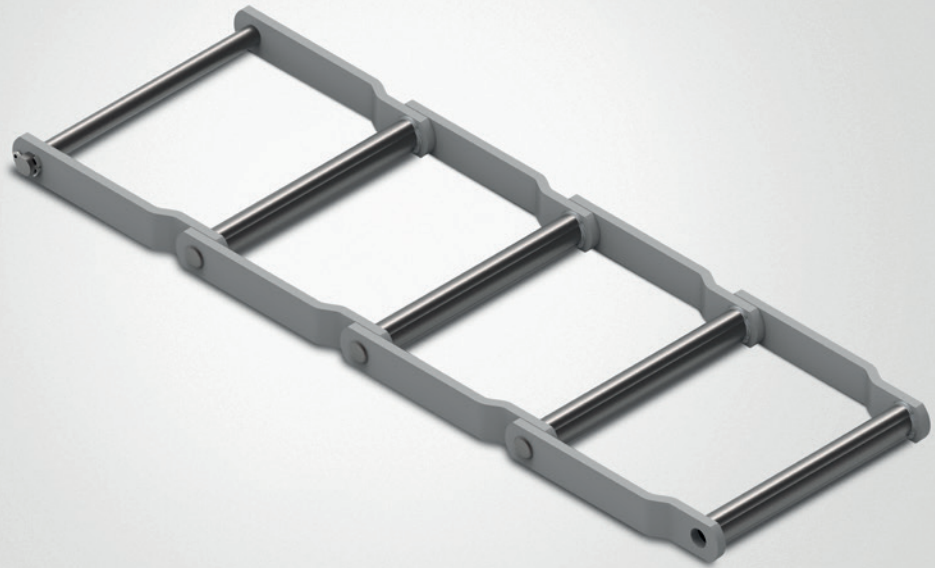
Drawings / product data



### KettenWulf welded steel chains – narrow series

#### KW WHX series

Designation	Pitch [mm]	Min. inner width [mm]	Max. inner width [mm]	Max. bush Ø [mm]	Max. pin Ø [mm]	Max. pin length [mm]	Max. overhang connecting pin [mm]	Plate thickness [mm]	Plate height [mm]	Min. breaking load [N]	Max. working load [N]	Weight [kg/m]
Chain type	p	b <sub>1</sub>	b	d <sub>2</sub>	d <sub>1</sub>	l	k	S	g	F <sub>B</sub>	≈ q	
KW WHX124	101.600	38.10	71.50	36.55	19.05	108.00	4.40	9.50	38.10	320000	32700	12.50
KW WHX124HD	103.200	38.10	76.30	41.28	25.40	123.70	4.90	12.70	50.80	540000	66800	20.70
KW WHX111	120.900	50.80	85.60	36.55	19.05	123.20	5.80	9.50	38.10	320000	39500	12.50
KW WHX111HD	120.900	57.15	91.96	36.53	19.05	135.00	4.00	12.70	50.80	320000	39500	19.10
KW WHX132	153.670	69.85	111.60	44.50	25.40	159.00	4.40	12.70	50.80	540000	66800	20.50
KW WHX132HD	153.670	69.85	119.03	44.50	25.40	173.70	5.70	15.90	50.80	540000	69300	24.80
KW WHX106	152.400	38.10	71.50	36.55	19.05	108.00	4.40	9.50	38.10	320000	32700	9.80
KW WHX150	153.670	69.85	111.60	44.50	25.40	159.00	4.40	12.70	63.50	540000	66800	24.40
KW FWHX150	153.670	69.85	110.00	44.50	25.00	156.00	6.00	12.00	65.00	520000	64500	24.70
KW WHX155	153.670	69.85	112.10	44.50	28.40	164.90	10.10	14.30	63.50	660000	77800	27.60
KW WHX157	153.670	69.85	118.10	44.50	28.55	174.00	11.20	15.90	63.50	750000	80900	29.40
KW WHX159	155.580	73.00	118.10	50.80	31.50	167.80	1.80	15.90	76.20	930000	90000	38.40
KW WHX4855	304.800	69.85	116.90	44.50	31.55	166.10	2.50	15.90	63.50	780000	76800	22.50
KW WHX4859	304.800	73.00	118.10	50.80	31.50	167.80	1.80	15.90	76.20	930000	87500	28.90



## Welded steel chains (WSC) “wide” series WDH / WDR

The chains of the “wide” series are mainly used as scraper chains for transporting heavy loads. In this type of application, the chains are exposed to high impact loads and a highly abrasive environment. The wide series is available in two different versions. Their designations reflect the heat treatment used for producing their components.

### **WDH series:**

All components of the KettenWulf WDH series are fully heat treated. This improves the chains wear resistance and increases its breaking load and fatigue strength.

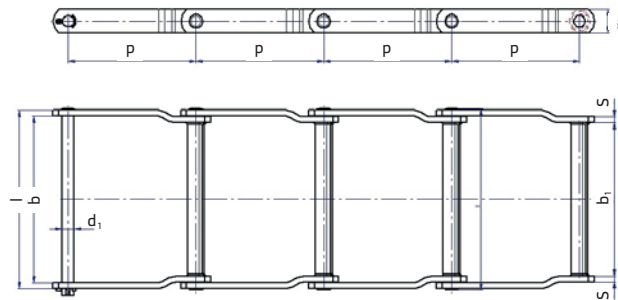
### **WDR series:**

The pins of the KettenWulf WDR series are heat treated to ensure optimal wear resistance. Link plates and bushes are untreated.

# WSC chains

## WDH /WDR series

Drawings / product data



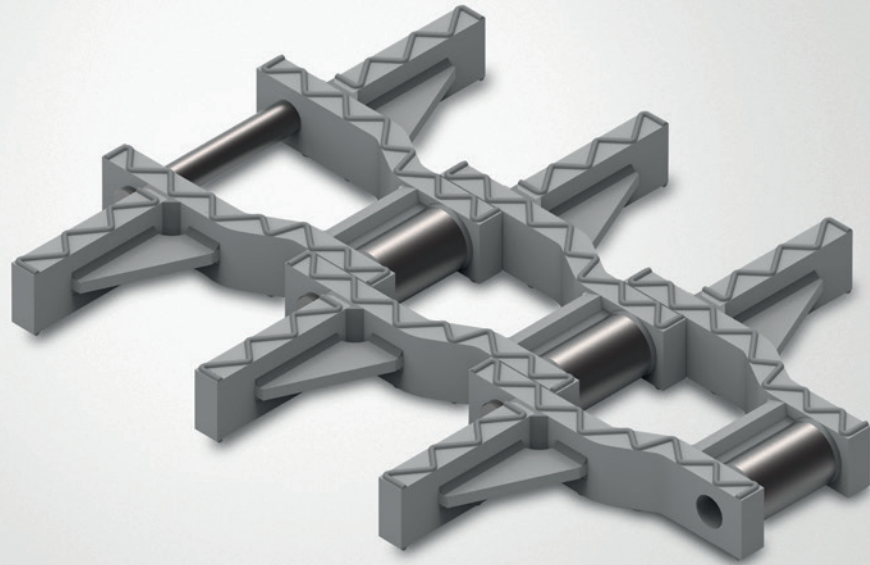
### KettenWulf welded steel chains – wide series

#### KW WDH series

Designation	Pitch [mm]	Min. inner width [mm]	Max. inner width outer [mm]	Max. pin Ø [mm]	Max. pin length [mm]	Max. overhang connecting pin [mm]	Plate thickness [mm]	Plate height [mm]	Min. breaking load [N]	Max. working load [N]	Weight [kg/m]
Chain type	p	b <sub>1</sub>	b	d <sub>1</sub>	l	k	S	σ	F <sub>g</sub>	≈ q	
KW WDH104	152.400	104.60	136.90	19.05	175.20	6.80	9.50	38.10	310000	44500	12.00
KW WDH110	152.400	228.60	263.90	19.05	302.30	6.70	9.50	38.10	310000	45000	17.00
KW WDH120	152.400	222.20	260.40	22.23	307.50	6.50	12.70	50.80	500000	66800	28.70
KW WDH112	203.200	228.60	263.90	19.05	302.30	6.70	9.50	38.10	310000	44500	14.10
KW WDH116	203.200	325.80	358.70	19.05	397.20	6.40	9.50	44.50	320000	51200	18.80
KW WDH118	203.200	334.00	378.45	22.23	427.90	6.50	12.70	50.80	500000	66800	32.20
KW WDH480	203.200	282.40	324.10	22.23	370.90	6.50	12.70	50.80	500000	66800	27.00
KW WDH580	203.200	282.40	324.10	25.40	370.80	7.80	12.70	50.80	540000	91200	29.20
KW WDH680	203.200	282.40	330.20	25.40	389.20	7.80	16.00	50.80	540000	91200	32.50
KW WDH2210	155.850	228.60	263.90	19.05	302.36	6.70	9.50	38.10	310000	44500	16.70
KW WDH2380	207.290	282.40	324.10	22.23	370.90	6.50	12.70	50.80	500000	66800	26.70

#### KW WDR series

Designation	Pitch [mm]	Min. inner width [mm]	Max. inner width outer [mm]	Max. pin Ø [mm]	Max. pin length [mm]	Max. overhang connecting pin [mm]	Plate thickness [mm]	Plate height [mm]	Min. breaking load [N]	Max. working load [N]	Weight [kg/m]
Chain type	p	b <sub>1</sub>	b	d <sub>1</sub>	l	k	S	σ	F <sub>g</sub>	≈ q	
KW WDR104	152.400	104.60	136.90	19.05	175.20	6.80	9.50	38.10	204000	28500	12.00
KW WDR110	152.400	228.60	263.90	19.05	302.30	6.70	9.50	38.10	204000	28000	17.00
KW WDR120	152.400	222.20	260.40	22.23	307.50	6.50	12.70	50.80	390000	48000	28.80
KW WDR112	203.200	228.60	263.90	19.05	302.30	6.70	9.50	38.10	204000	28500	14.10
KW WDR116	203.200	325.80	358.70	19.05	397.20	6.40	9.50	44.50	262000	36500	18.80
KW WDR118	203.200	334.00	378.45	22.23	427.90	6.50	12.70	50.80	390000	48000	32.10
KW WDR480	203.200	282.40	324.10	22.23	370.90	6.50	12.70	50.80	390000	48000	26.90
KW WDR2210	155.850	228.60	263.90	19.05	302.30	6.70	9.50	38.10	204000	28500	16.70
KW WDR2380	207.290	282.40	324.10	22.23	370.90	6.50	12.70	50.80	390000	48000	26.70



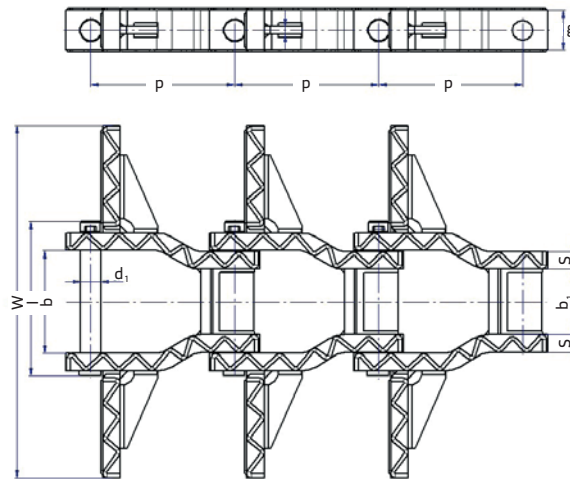
## Welded steel chains (WSC) “reinforced clinker” series (WHX HD)

The typical application for KettenWulf “reinforced clinker” chains (WHX HD) is the cement industry. The chains are used for conveying cold and hot clinker. Apart from that, the reinforced clinker chains are also used for other highly abrasive conveyance environments. Their specially selected materials ensure that KettenWulf WHX HD chains gain the highest breaking loads making them the perfect fit for every critical application.

KettenWulf WHX HD chains are produced with a hardfacing on the link plates’ sliding surfaces by default which guarantees an enhanced wear resistance of the link plates. Pins and bushes are through hardened and induction-hardened in addition. The high surface hardness of the induction-hardened surface ensures optimal wear resistance. The quenched and tempered link plates and the lugs have a special shape to increase their conveyance capacity.

# WSC chains WHX HD series

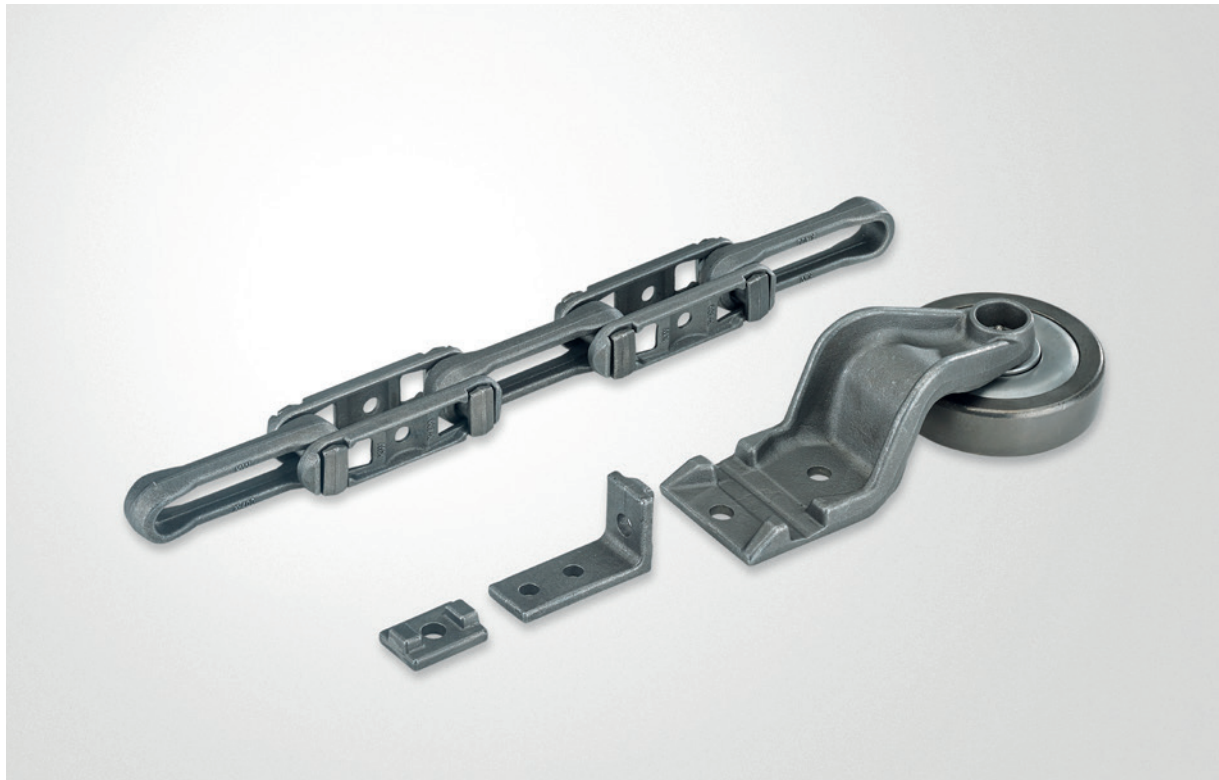
Drawings / product data



## KettenWulf welded steel chains – reinforced clinker series

### KW WHX HD series

Designation	Pitch [mm]	Min. inner width [mm]	Max. inner width outer [mm]	Total width over wing [mm]	Max. pin Ø [mm]	Max. pin length [mm]	Plate thickness [mm]	Plate height [mm]	Min. breaking load [N]	Max. working load [N]	Weight [kg/m]
Chain type	p	b <sub>1</sub>	b	W	d <sub>1</sub>	l	S	g	F <sub>br</sub>	≈ q	
KW WHX5157HD	153.670	69.80	118.00	203.00-355.00	29.00	177.00	16.00	63.50	520000	84000	12.00
KW WHX6067HD	228.600	92.20	140.00	254.00-660.00	32.00	208.00	19.00	63.50	880000	110000	17.00
KW WHX6121HD	228.600	92.20	160.00	254.00-762.00	32.00	248.00	28.00	63.50	1250000	130000	28.70
KW WHX5121HD	228.600	92.20	160.00	254.00-762.00	32.00	248.00	28.00	63.50	1250000	130000	14.10



## Standard & premium drop-forged rivetless chains

### **KettenWulf standard drop-forged rivetless chains**

The KettenWulf standard chains are made of SAE-5140 high quality steel. The actual breaking loads are significantly higher than those required by the standard. These chains are mostly used for applications without any particular requirements for wear resistance and chain pull.

### **KettenWulf premium**

KettenWulf premium are the ideal choice for all critical applications which require maximum wear resistance and breaking loads. KettenWulf premium rivetless detachable chains are made of SAE-4140 and SAE-8640 steels of particularly high quality. Each component of these chains receives a special surface treatment guaranteeing unrivalled surface quality.

In addition, the inner surfaces of the link plates' joints are machined to ensure the best possible friction combination between pin and inner link plate. The result is an ultimate wear resistance.

By using SAE-4140 and SAE-8640 high quality steels with special heat treatment, KettenWulf premium chains gain the highest breaking loads and particularly high resistance to impact loads.

Upon request, we can supply chains with the following corrosion protection properties:

Zinc plated:	DIN 50961	10 to 13µm
Hot-dip galvanised:	DIN 50976	60 to 90µm

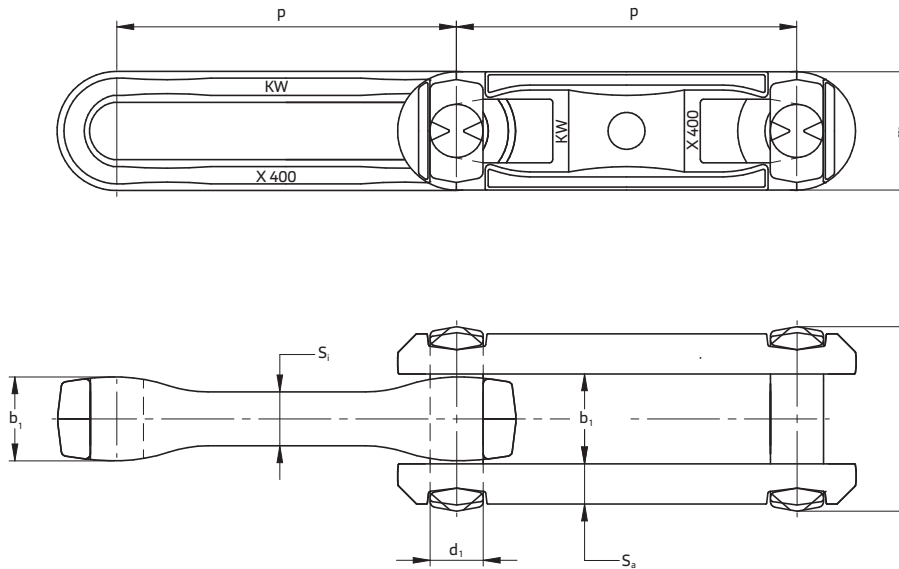
Typical applications for the chains are overhead conveyor, scrapers / chip conveyors or in filtration facilities.



# Standard drop-forged rivetless chain

## Made of SAE-5140 high quality steel

Drawings / product data



### KettenWulf standard drop-forged rivetless chain

#### KW X standard

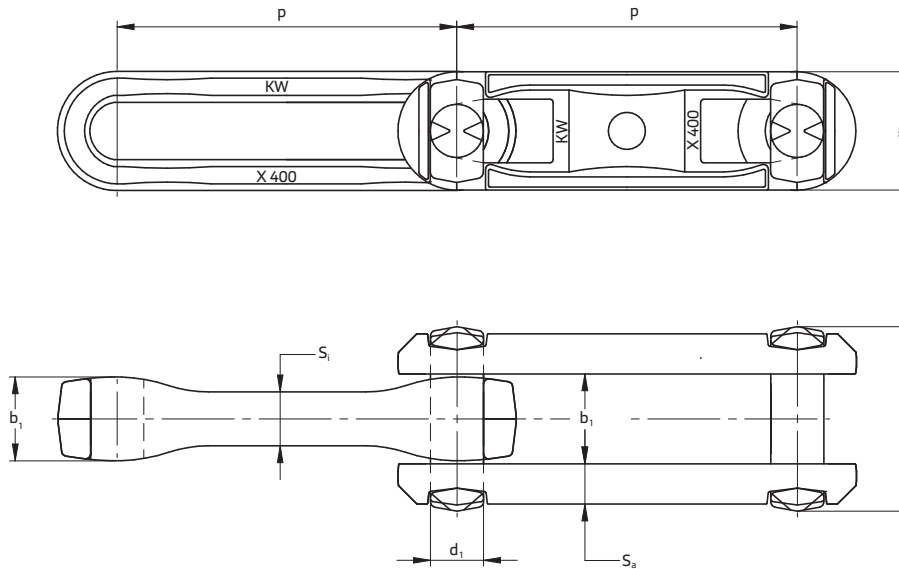
Designation	Material	Pitch [mm]	Max. height [mm]	Max. pin length [mm]	Width [mm]	Inner plate thickness [mm]	Outer plate thickness [mm]	Max. pin Ø [mm]	Weight [kg/m]	Min. breaking load [kN]
Chain type		p	g	l	b <sub>i</sub>	S <sub>i</sub>	S <sub>o</sub>	d <sub>i</sub>	≈q	F <sub>g</sub>
KW X348	SAE 5140	76.550	27.88	46.00	18.80	13.20	10.20	12.70	3.10	110
KW X400	SAE 5140	101.600	36.00	57.00	25.40	16.00	11.90	16.00	4.50	220
KW X458	SAE 5140	102.400	36.00	57.00	25.40	16.00	11.90	16.00	4.50	220
KW X678	SAE 5140	153.200	50.80	77.00	31.80	21.00	18.70	22.00	9.30	320
KW CC100	SAE 5140	100.400	36.65	59.50	25.00	16.50	12.20	16.00	4.60	220
KW S348	SAE 5140	76.900	28.80	42.50	18.80	13.20	10.20	12.70	3.10	110
KW S458	SAE 5140	102.600	38.00	55.00	25.30	16.25	11.90	16.00	4.50	220

» The standard packing unit for drop-forged rivetless chains is 10 ft.

## Premium drop-forged rivetless chain

Made of SAE-4140 & SAE-8640 grade steel of particularly high quality

Drawings / product data



KettenWulf premium drop-forged rivetless chain

KW X premium

Designation	Material	Pitch [mm]	Max. height [mm]	Max. pin length [mm]	Width [mm]	Inner plate thickness [mm]	Outer plate thickness [mm]	Pin Ø [mm]	Weight [kg/m]	Min. breaking load [kN]
Chain type		p	g	l	b <sub>1</sub>	S <sub>1</sub>	S <sub>a</sub>	d <sub>1</sub>	≈ q	F <sub>a</sub>
KW X228	SAE 4140	50.800	18.20	27.90	11.20	8.65	-	6.60	1.20	30
KW X348	SAE 4140	76.550	27.88	46.00	18.80	13.20	10.20	12.70	3.10	190
KW X458	SAE 4140	102.400	35.81	57.40	25.30	16.25	11.90	16.00	4.50	270
KW X458 (stainless)	SUS 304	102.400	35.81	57.40	25.30	16.25	11.90	16.00	4.50	140
KW X458	SAE 8640	102.400	35.81	57.40	25.30	16.25	11.90	16.00	4.50	300
KW X658	SAE 4140	153.200	35.90	57.40	25.30	16.25	8.40	15.75	5.90	270
KW X658	SAE 8640	153.200	35.90	57.40	25.30	16.25	8.40	15.75	5.90	300
KW X678	SAE 4140	153.200	50.80	77.00	31.80	21.00	18.70	22.00	9.30	450
KW X678	SAE 8640	153.200	50.80	77.00	31.80	21.00	18.70	22.00	9.30	500
KW CC100	SAE 4140	100.400	36.65	59.50	25.00	16.50	12.20	16.00	4.60	280

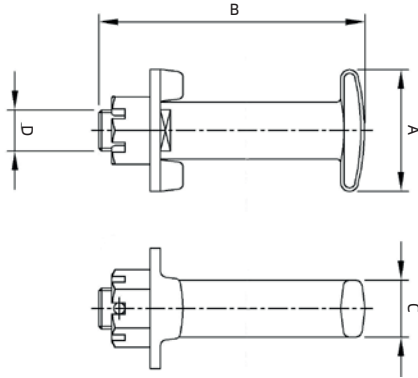
» The standard packing unit for drop-forged rivetless chain is 10 ft.

» Other material grades available upon request.

# Attachments for drop-forged rivetless chain

## T-pins – extended pins

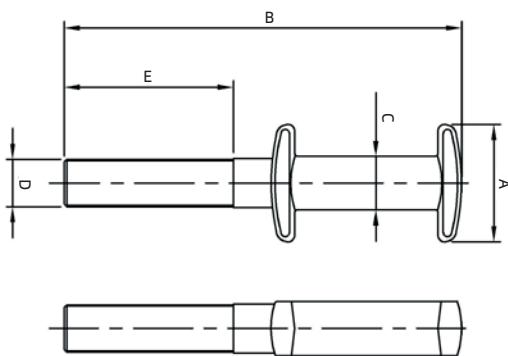
Drawings / product data



T-pin with thread + washer + castle nut

T-pin with thread + washer + castle nut				
Chain type	A [mm]	B [mm]	C [mm]	D [mm]
KW X-348	25.40	62.30	12.50	M10
KW X-458	30.13	82.50	16.83	M16
KW X-678	47.60	104.00	22.20	M16
KW X-678	47.50	100.10	22.20	M16

Drawings / product data



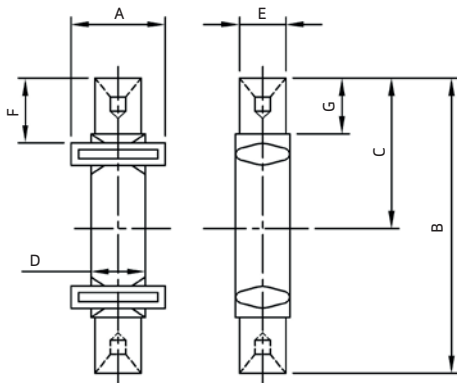
Extended pin with thread

Extended pin with thread					
Chain type	A [mm]	B [mm]	C [mm]	D [mm]	E [mm]
KW X-348	26.50	75.00	12.80	12.00	20.00
KW X-458	31.24	94.50	16.00	12.70	25.40
KW X-678	47.60	124.60	21.90	15.70	22.00

## Attachments for drop-forged rivetless chain

### Extended pin

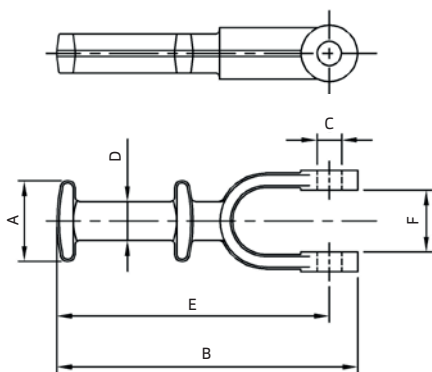
Drawings / product data



Pins extended on both sides

Pins extended on both sides							
Chain type	A [mm]	B [mm]	C [mm]	[mm]	E [mm]	F [mm]	G [mm]
KW X-678	47.60	126.40	63.20	21.60	19.10	28.80	17.30

Drawings / product data



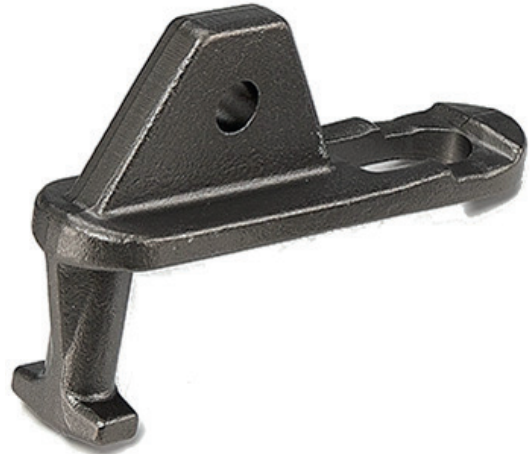
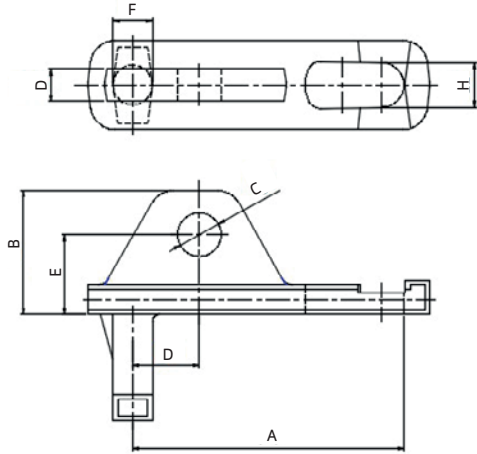
Extended pin with adapter

Extended pin with adapter						
Chain type	A [mm]	B [mm]	C [mm]	D [mm]	E [mm]	F [mm]
KW X-348	26.00	91.45	9.90	12.50	84.40	14.00

# Attachments for drop-forged rivetless chain

## Pusher Dog outer link plates

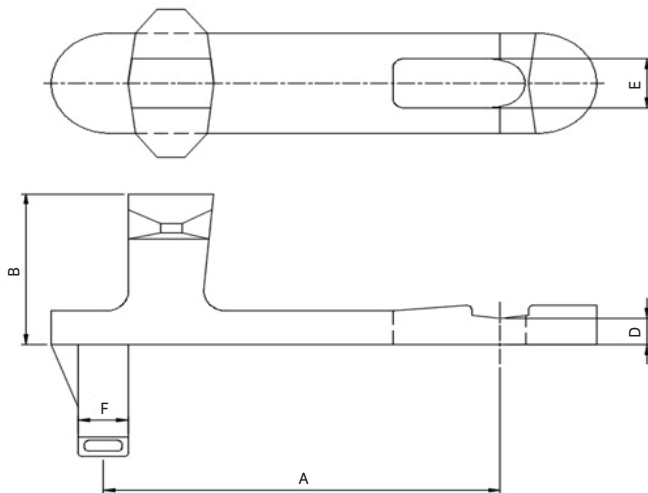
Drawings / product data



Pusher Dog outer link plates

Pusher Dog outer link plates								
Chain type	A [mm]	B [mm]	C [mm]	D [mm]	E [mm]	F [mm]	G [mm]	H [mm]
KW X-458	110.60	52.50	12.83	28.40	32.90	15.80	12.00	19.00
KW X-678	163.90	69.60	17.50	59.00	37.00	22.00	13.20	25.00

Drawings / product data



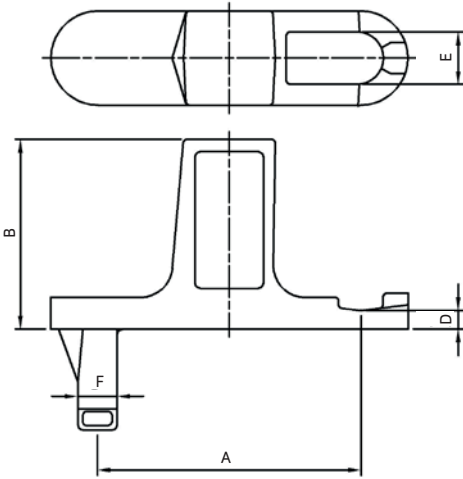
Pusher Dog outer link plates

Pusher Dog outer link plates					
Chain type	A [mm]	B [mm]	C [mm]	D [mm]	E [mm]
KW X-458	102.70	68.00	7.40	18.00	15.80
KW X-678	153.70	66.29	11.20	25.00	22.00
KW X-678	153.70	82.50	11.20	25.00	22.00

# Attachments for drop-forged rivetless chain

## Pusher Dog outer link plates

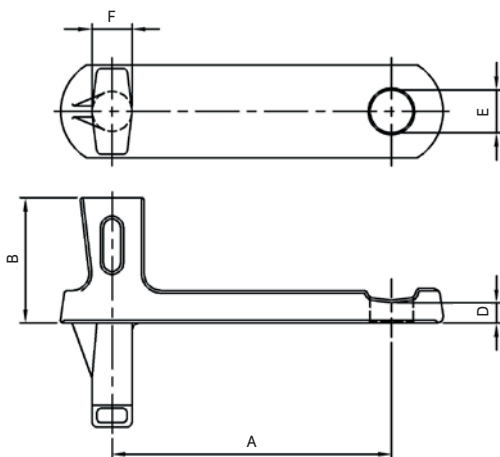
Drawings / product data



Pusher Dog outer link plates

Pusher Dog outer link plates					
Chain type	A [mm]	B [mm]	C [mm]	D [mm]	E [mm]
KW X-348	76.80	81.00	5.70	14.50	12.50
KW X-348	76.80	61.50	5.40	14.00	12.50

Drawings / product data



Pusher Dog outer link plates

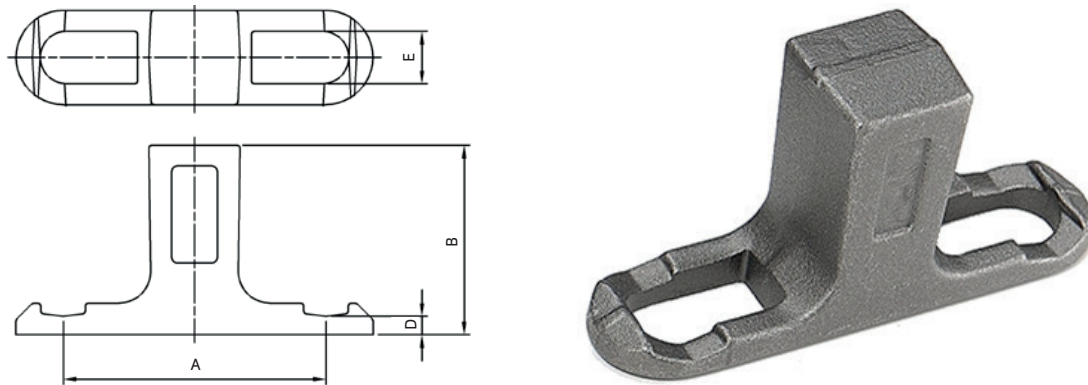
Pusher Dog outer link plates					
Chain type	A [mm]	B [mm]	C [mm]	D [mm]	E [mm]
KW X-458	102.70	56.00	7.30	16.70	16.00
KW X-458	102.70	84.60	7.30	19.00	15.80
KW X-678	153.70	63.50	11.20	25.00	22.00
KW X-678	153.70	68.00	11.40	23.50	22.00



## Attachments for drop-forged rivetless chain

### Pusher Dog outer link plates

Drawings / product data



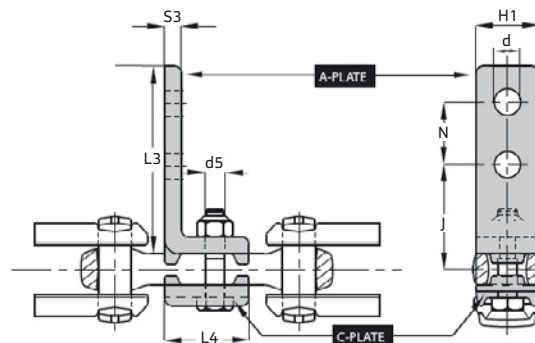
Pusher Dog outer link plates

Pusher Dog outer link plates				
Chain type	A [mm]	B [mm]	C [mm]	D [mm]
KW X-458	101.00	72.00	7.00	20.00
KW X-458	102.70	55.00	7.30	19.00
KW X-458	102.70	50.80	7.30	17.00
KW X-678	153.70	90.00	11.20	-
KW X-678	153.70	66.00	11.20	-

## A & C plates (clamping angles and counter-plates)

### For attaching scraper

Drawings / product data



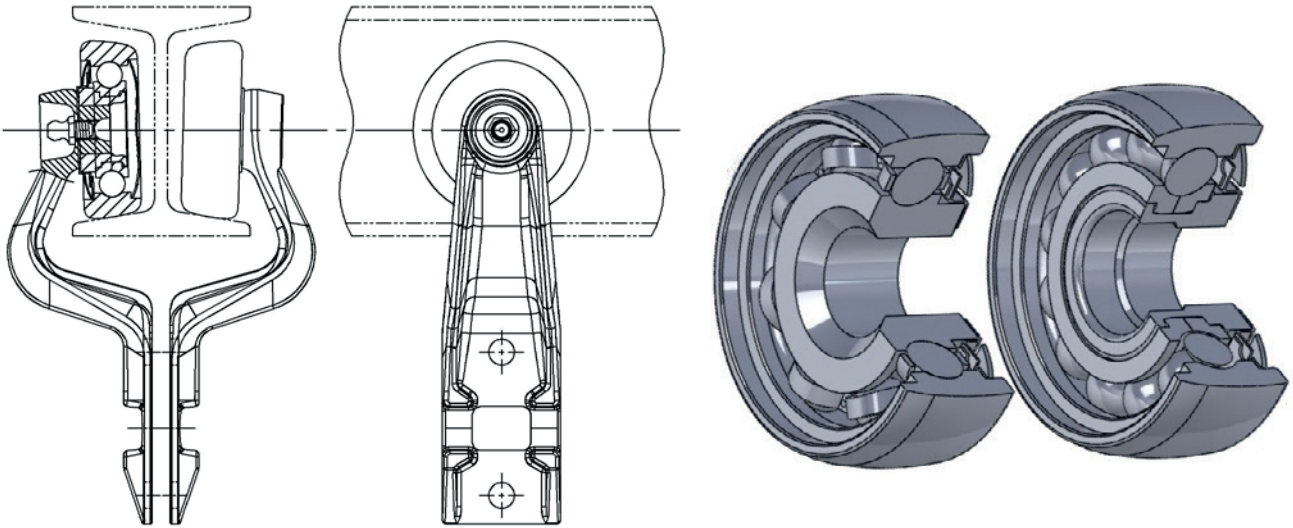
Clamping angles and counter-plates

KW X (clamping angles with counter-plates)									
Chain type		N [mm]	J [mm]	L3 [mm]	L4 [mm]	H1 [mm]	d [mm]	d5 [mm]	S3 [mm]
KW A-Plate 3	KW X348	26	43.3	80	35	26	11	M10x40	7
KW C-Plate 3	KW X348	26	43.3	80	35	26	11	M10x40	7
KW A-Plate 4	KW CC, KW X400, KW X458	30	50	88	50	35	11	M12x45	8
KW C-Plate 4	KW CC, KW X400, KW X458	30	50	88	50	35	11	M12x45	8

» Counter-plates with additional forged fin for locking the thread are available upon request.

## Rollers for trolleys

Drawings / product data



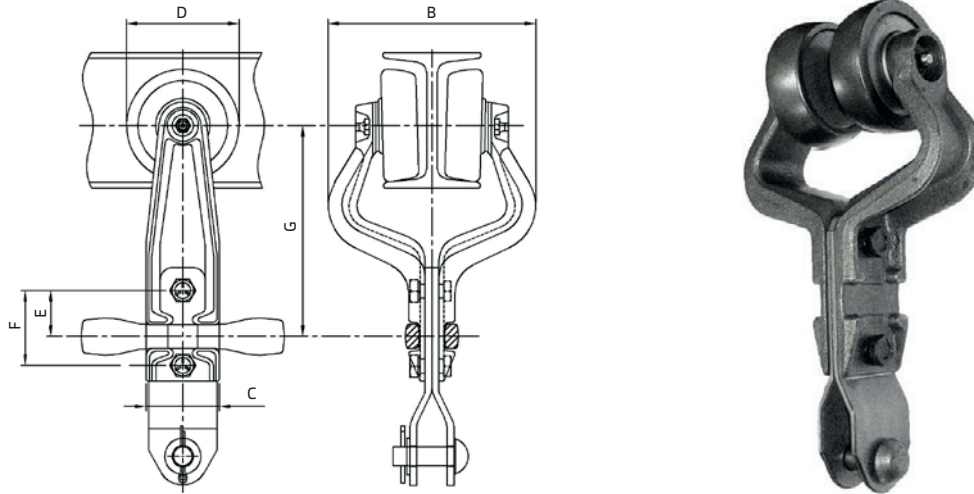
### KettenWulf support rollers for trolleys

Support rollers for trolleys				
Size of the roller retainers	Type of roller	Inner Diameter	Outer Diameter	Width
3"	Full Ball	Ø 16.00	Ø 54.00	19.10
3"	Full Ball	Ø 16.00	Ø 56.00	19.10
3"	Full Ball	Ø 16.00	Ø 59.00	19.10
3"	Retainer	Ø 16.00	Ø 54.00	19.10
3"	Retainer	Ø 16.00	Ø 56.00	19.10
3"	Retainer	Ø 16.00	Ø 59.00	19.10
4"	Full Ball	Ø 25.60	Ø 80.00	25.40
4"	Retainer	Ø 25.40	Ø 80.00	25.40
6"	Full Ball	Ø 30.10	Ø 125.00	33.40

# Trolleys

\* Special attachment link is not included in the standard delivery.

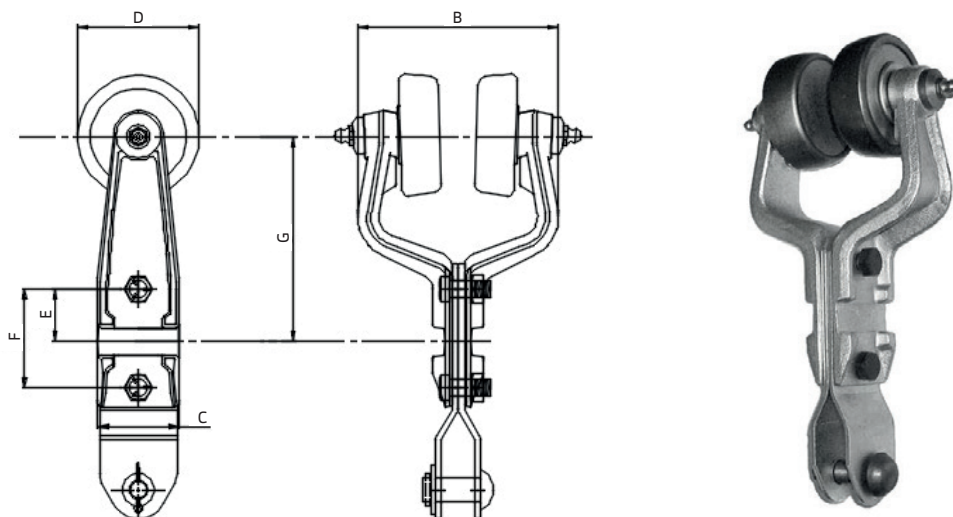
## Drawings / product data



**KW X348 Trolley**

KW X348 Trolley										
Roller retainer	Type of trolley	Chain	B [mm]	C [mm]	D [mm]	E [mm]	F [mm]	G [mm]	I Beam	
KW 348	Overhead	X-348	118.30	39.70	59.00	25.40	47.70	101.75	3"	

## Drawings / product data



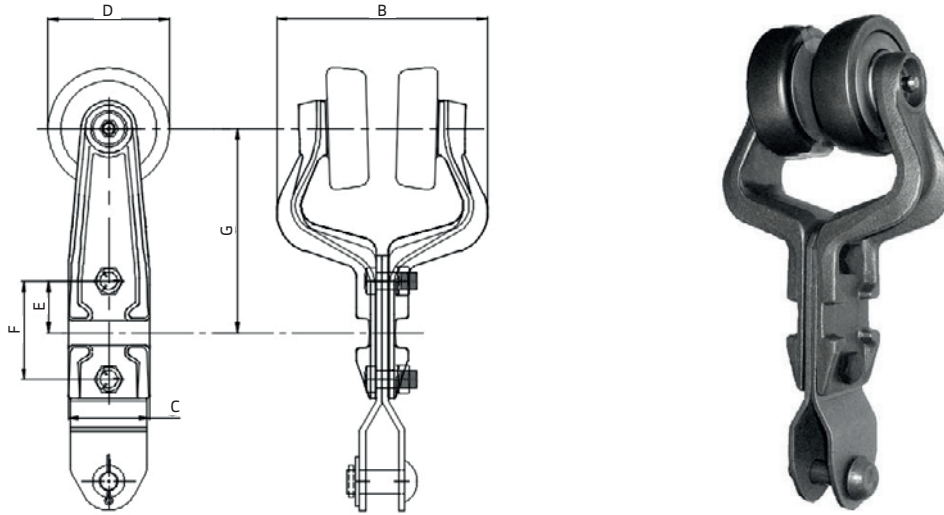
**KW X348 Trolley**

KW X348 Trolley										
Roller retainer	Type of trolley	Chain	B [mm]	C [mm]	D [mm]	E [mm]	F [mm]	G [mm]	I Beam	
KW 348/B	Overhead	X-348	97.20	39.70	56.00	25.40	47.70	100.02	3"	

# Trolleys

\* Special attachment link is not included in the standard delivery.

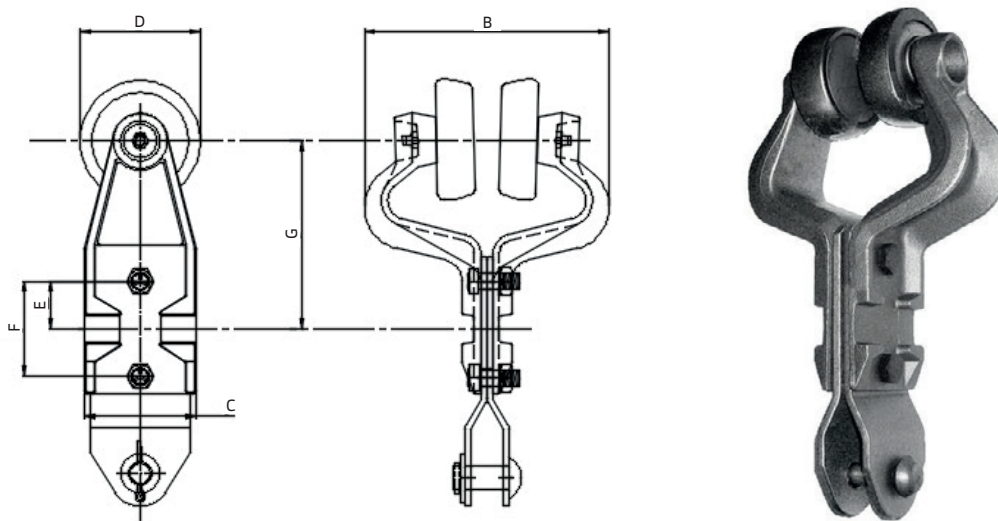
## Drawings / product data



**KW X348 Trolley**

KW X348 Trolley										
Roller retainer	Type of trolley	Chain	B [mm]	C [mm]	D [mm]	E [mm]	F [mm]	G [mm]	I Beam	
KW 348/C	Overhead	X-348	103.00	39.50	59.00	25.40	47.70	99.30	3"	

## Drawings / product data



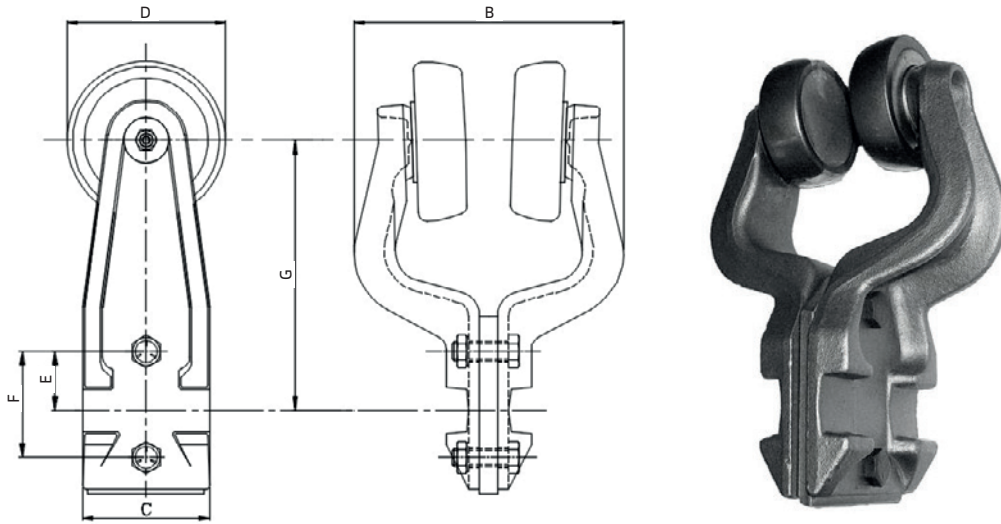
**KW X458 Trolley**

KW X458 Trolley										
Roller retainer	Type of trolley	Chain	B [mm]	C [mm]	D [mm]	E [mm]	F [mm]	G [mm]	I Beam	
KW 458/B	Overhead	X-458	102.52	54.22	59.00	33.32	53.97	116.78	3"	

# Trolleys

\* Special attachment link is not included in the standard delivery.

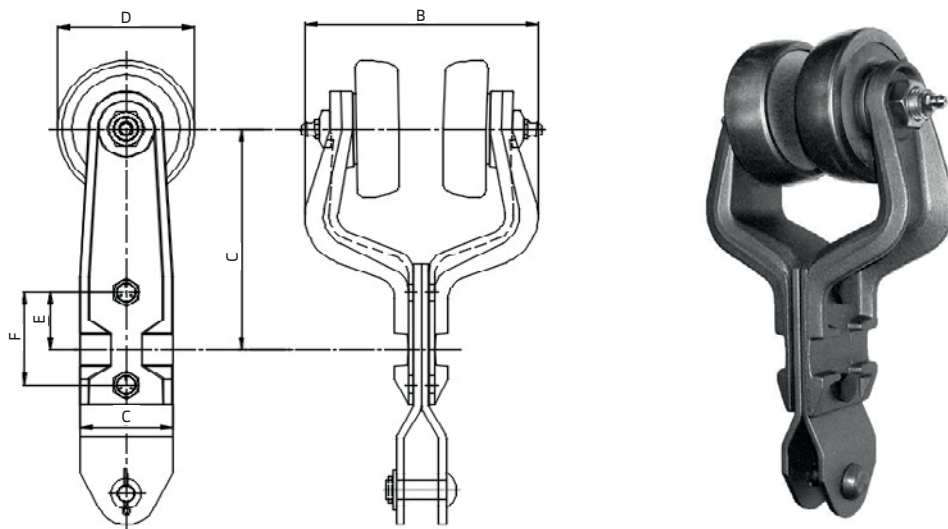
## Drawings / product data



**KW X458 Trolley**

KW X458 Trolley									
Roller retainer	Type of trolley	Chain	B [mm]	C [mm]	D [mm]	E [mm]	F [mm]	G [mm]	I Beam
KW 458/C	Overhead	X-458	136.00	58.34	80.00	33.32	53.98	128.57	4"

## Drawings / product data



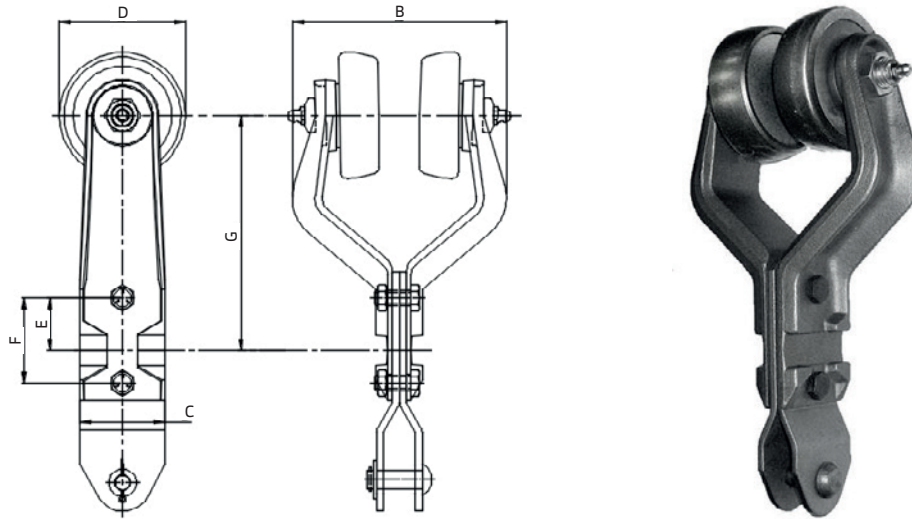
**KW X458 Trolley**

KW X458 Trolley									
Roller retainer	Type of trolley	Chain	B [mm]	C [mm]	D [mm]	E [mm]	F [mm]	G [mm]	I Beam
KW 458/D	Overhead	X-458	126.00	53.95	80.00	33.30	54.00	95.25	4"

## Trolleys

\* Special attachment link is not included in the standard delivery.

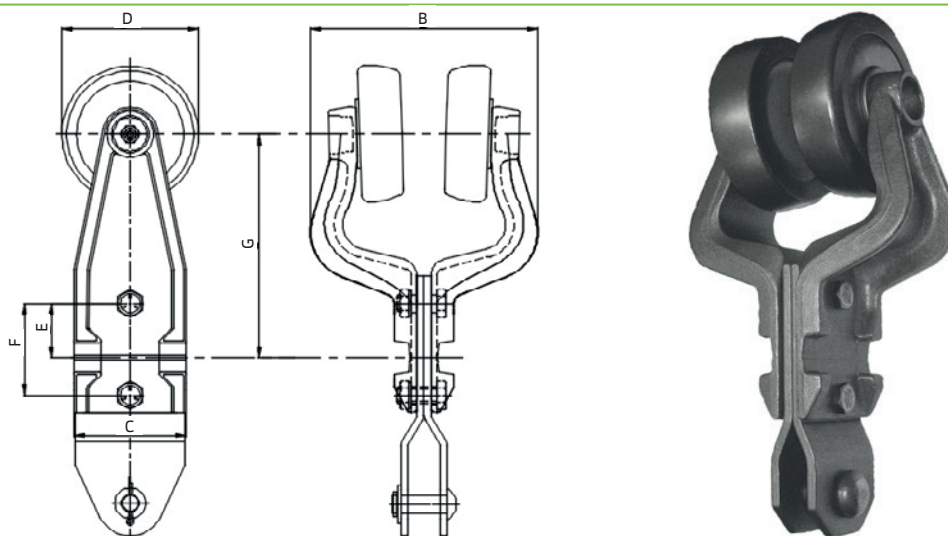
### Drawings / product data



**KW X458 Trolley**

KW X458 Trolley										
Roller retainer	Type of trolley	Chain	B [mm]	C [mm]	D [mm]	E [mm]	F [mm]	G [mm]	I Beam	
KW 458/E	Overhead	X-458	126.00	53.95	80.00	33.30	54.00	95.25	4"	

### Drawings / product data



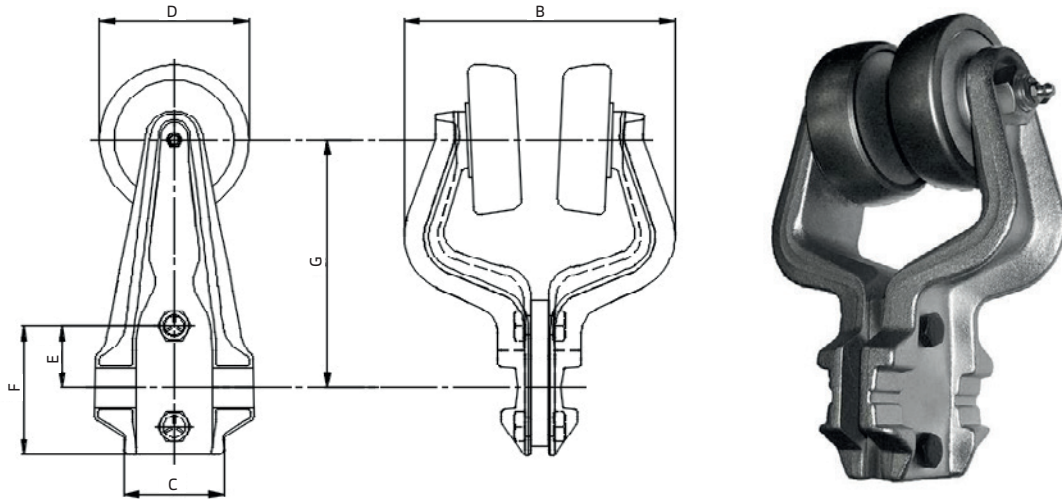
**KW X678 Trolley**

KW X678 Trolley										
Roller retainer	Type of trolley	Chain	B [mm]	C [mm]	D [mm]	E [mm]	F [mm]	G [mm]	I Beam	
KW 678	Overhead	X-678	175.04	85.50	125.50	41.28	69.85	169.85	6"	



# Trolleys

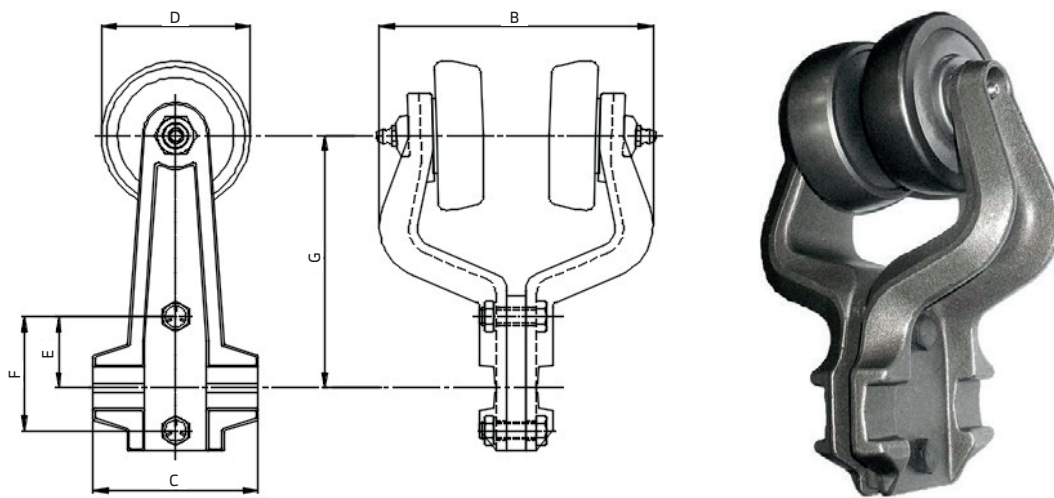
Drawings / product data



**KW X678 Trolley**

KW X678 Trolley										
Roller retainer	Type of trolley	Chain	B [mm]	C [mm]	D [mm]	E [mm]	F [mm]	G [mm]	I Beam	
KW 678/B	Overhead	X-678	144.50	53.95	80.00	33.00	54.00	132.30	4"	

Drawings / product data

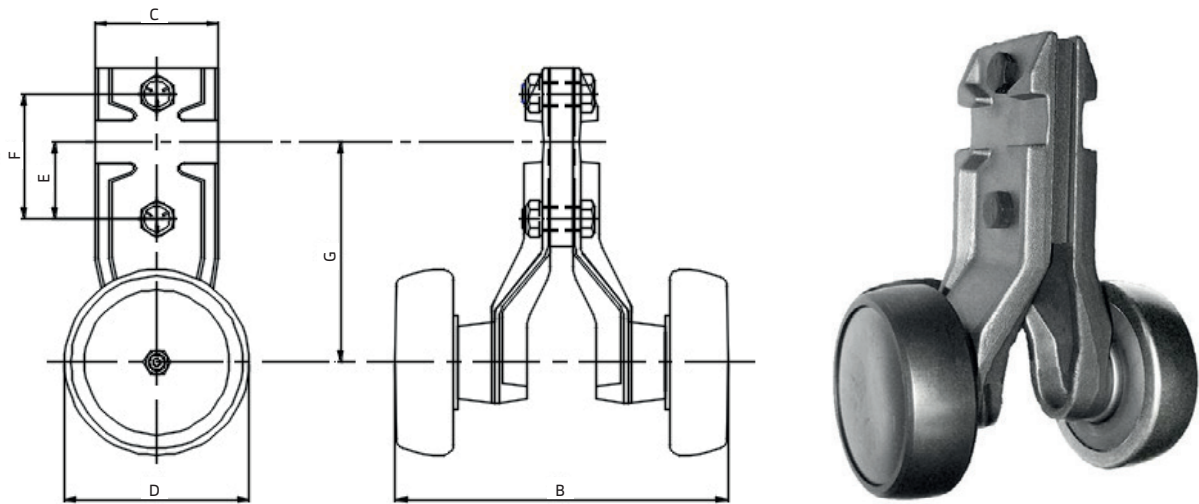


**KW X678 Trolley**

KW X678 Trolley										
Roller retainer	Type of trolley	Chain	B [mm]	C [mm]	D [mm]	E [mm]	F [mm]	G [mm]	I Beam	
KW 678/C	Overhead	X-678	126.00	85.73	80.00	33.30	54.00	95.25	4"	

## Inverted trolleys

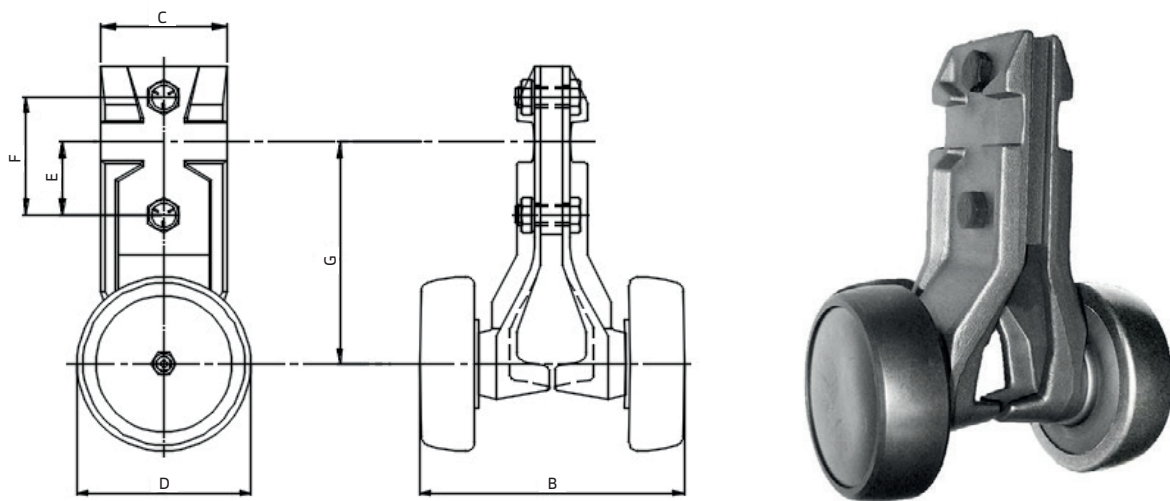
Drawings / product data



**KW X458 Inverted Trolley**

KW X458 Inverted Trolley										
Roller retainer	Type of trolley	Chain	B [mm]	C [mm]	D [mm]	E [mm]	F [mm]	G [mm]	I Beam	
KW 458/FT	Floor	X-458	126.00	53.95	80.00	33.30	54.00	95.25	4"	

Drawings / product data

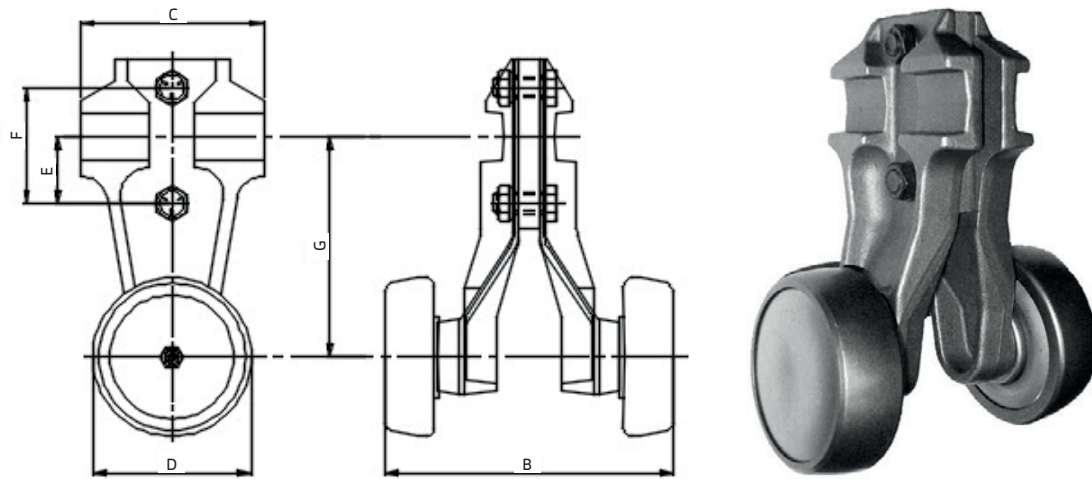


**KW X458 Inverted Trolley**

KW X458 Inverted Trolley										
Roller retainer	Type of trolley	Chain	B [mm]	C [mm]	D [mm]	E [mm]	F [mm]	G [mm]	I Beam	
KW 458/FT-B	Floor	X-458	129.98	58.30	80.00	33.40	54.00	101.60	4"	

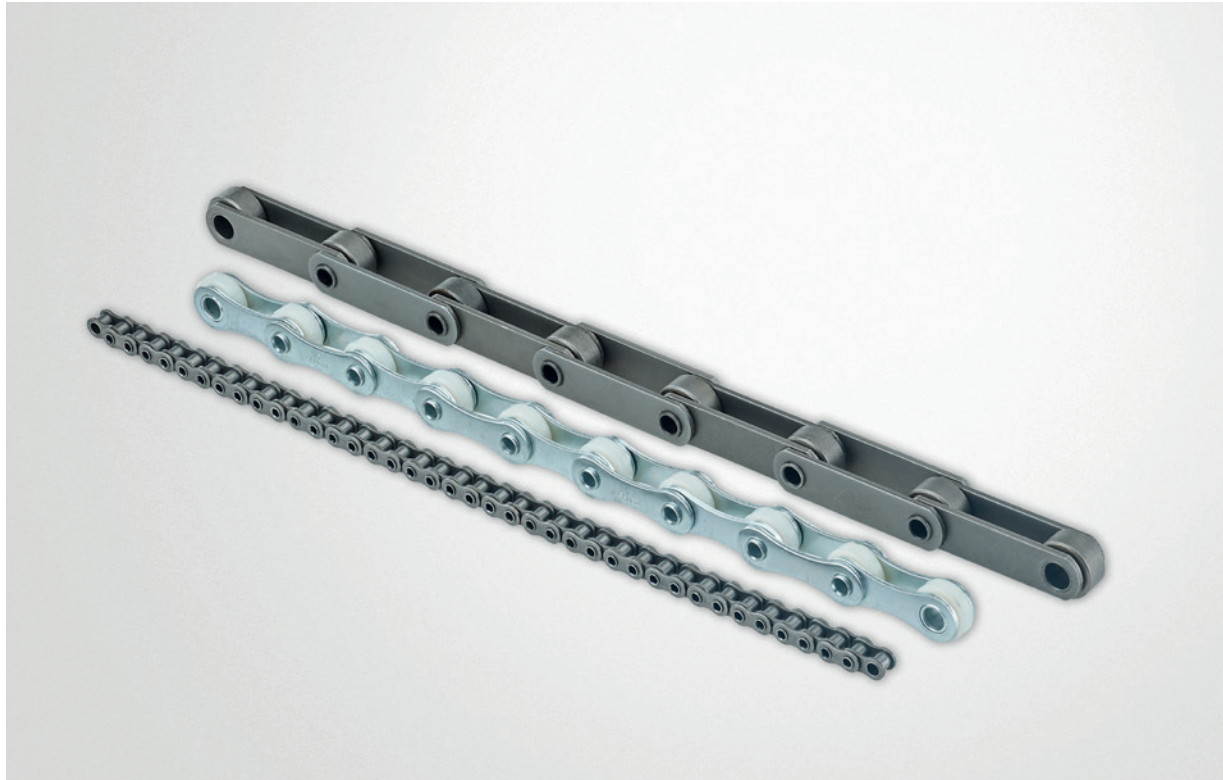
## Inverted trolleys

Drawings / product data



KW X458 Inverted Trolley

KW X458 Inverted Trolley									
Roller retainer	Type of trolley	Chain	B [mm]	C [mm]	D [mm]	E [mm]	F [mm]	G [mm]	I Beam
KW 458/FT-C	Floor	X-458	126.00	85.73	80.00	33.30	54.00	95.25	4"



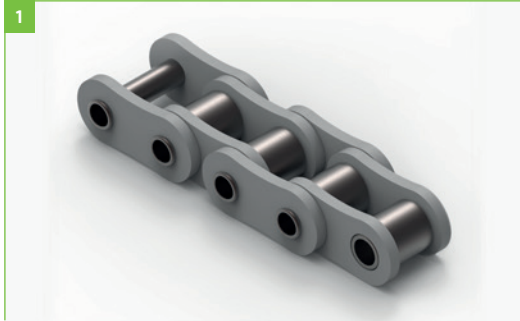
## Hollow pin chains

The precision and a long service life of the hollow pin chains are a top priority for KettenWulf. The hollow pins guarantee an unrestricted use of the chains and allow a simple installation of rods, screws or attachment angles.

All KettenWulf hollow pin chains have seamless, cold-extruded hollow pins. For highest precision, the chain strands are measured in pairs and clearly marked.

## Different hollow pin chain versions

**Figure 1:**  
HP – hollow pin chain

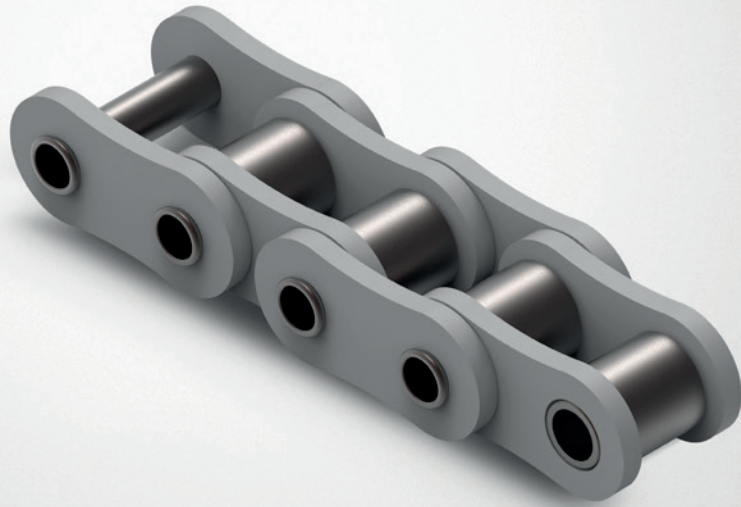


**Figure 2:**  
1650HP – hollow  
pin chain



**Figure 3:**  
DP-HP – hollow  
pin chain





## Hollow pin (HP) chains

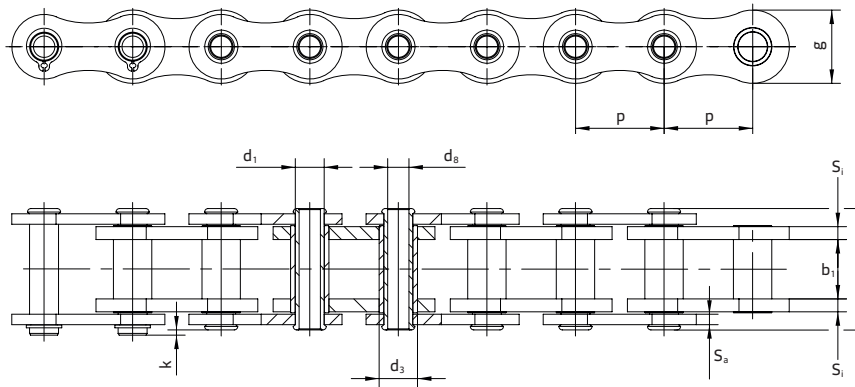
The KettenWulf HP “hollow pin” chains have the same basic dimensions as the standard roller chains and operate on standard sprockets.



# HP chains – design version A

## With simple pitch for standard sprockets

Drawings / product data



### KettenWulf bush chains with hollow pins – design version A

#### KW HP

Designation	Pitch [mm]	Min. inner width [mm]	Max. bush Ø [mm]	Max. pin Ø [mm]	Min. hollow pin internal Ø [mm]	Max. pin length [mm]	Max. overhang connecting pin [mm]	Inner plate thickness [mm]	Outer plate thickness [mm]	Plate height [mm]	Min. breaking load [N]	Weight [kg/m]	Designs
Chain type	p	b <sub>1</sub>	d <sub>3</sub>	d <sub>1</sub>	d <sub>2</sub>	l	k	S <sub>1</sub>	S <sub>2</sub>	g	F <sub>b</sub>	≈q	
KW 08BHP	12.700	7.75	8.50	6.37	4.50	16.70	1.30	1.60	1.60	11.80	8900	0.60	A
KW 08BHB	12.700	7.75	8.51	6.30	4.20	16.80	1.20	1.60	1.60	12.00	12000	0.62	A
KW 40HP	12.700	7.85	7.95	5.63	4.10	16.50	1.00	1.50	1.50	12.00	12700	0.60	A
KW 50HP	15.875	9.40	10.16	7.03	5.13	20.70	1.20	2.00	2.00	15.09	20000	0.90	A
KW 60HP	19.050	12.70	11.91	8.31	6.10	25.80	0.60	2.40	2.40	18.00	26500	1.40	A
KW 80HP	25.400	15.75	15.88	11.30	8.10	32.40	1.40	3.20	3.20	24.00	51000	2.30	A

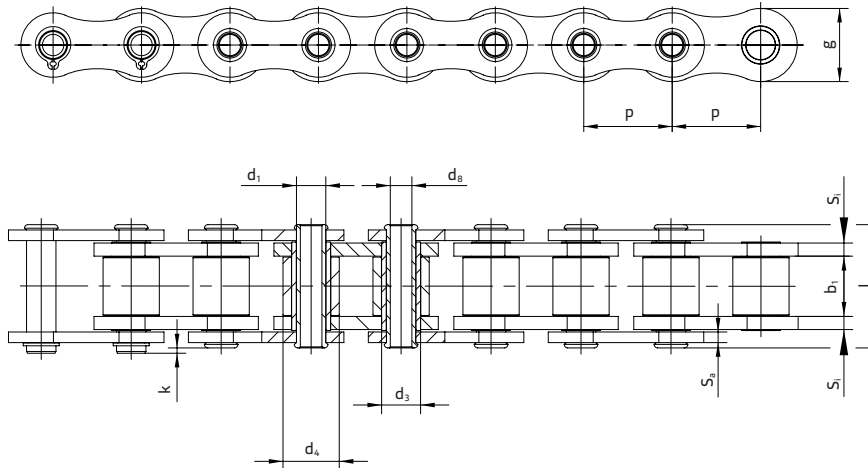
#### KW HP SS (stainless)

Chain type	p	b <sub>1</sub>	d <sub>3</sub>	d <sub>1</sub>	d <sub>2</sub>	l	k	S <sub>1</sub>	S <sub>2</sub>	g	F <sub>b</sub>	≈q	Designs
KW 08BHPSS	12.700	7.75	8.51	6.14	4.50	16.20	1.80	1.65	1.50	12.10	7800	0.60	A
KW 40HPSS	12.700	7.85	7.95	6.65	4.10	16.50	1.00	1.50	1.50	12.00	7700	0.60	A
KW 50HPSS	15.875	9.40	10.16	7.03	5.13	20.70	1.20	2.00	2.00	15.09	12500	0.90	A
KW 60HPSS	19.050	12.70	11.91	8.31	6.10	25.80	0.60	2.40	2.40	18.00	16800	1.40	A
KW 80HPSS	25.400	15.75	15.88	11.30	8.10	32.40	1.40	3.20	3.20	24.00	24000	2.30	A

# HP chains – design version B

## With simple pitch for standard sprockets

Drawings / product data



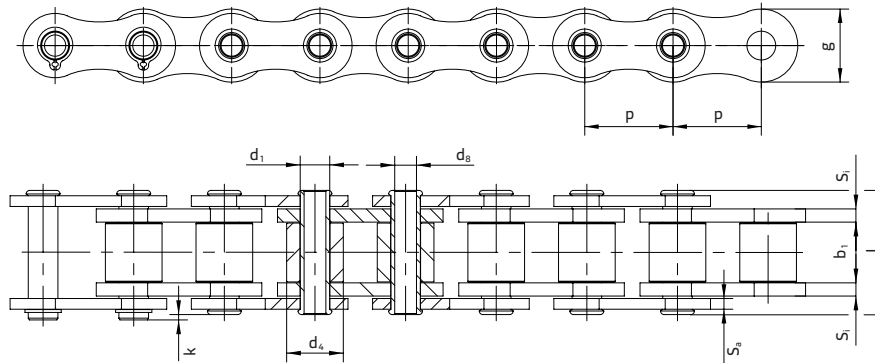
### KettenWulf roller chains with hollow pins – design version B

KW HP													
Designation	Pitch [mm]	Min. inner width [mm]	Max. roller Ø [mm]	Max. pin Ø [mm]	Min. hollow pin internal Ø [mm]	Max. pin length [mm]	Max. overhang connecting pin [mm]	Inner plate thickness [mm]	Outer plate thickness [mm]	Plate height [mm]	Min. breaking load [N]	Weight [kg/m]	Designs
Chain type	p	b <sub>i</sub>	d <sub>r</sub>	d <sub>1</sub>	d <sub>5</sub>	l	k	S <sub>i</sub>	S <sub>o</sub>	g	F <sub>br</sub>	≈ q	
KW 10BHB	15.875	9.65	10.16	5.94	4.04	19.30	1.30	1.70	1.70	14.70	17000	0.83	B
KW 12BHP	19.050	11.68	12.07	6.50	4.10	22.30	1.20	1.85	1.85	15.09	23600	1.10	B
KW 60HB	19.050	12.70	11.91	7.00	5.01	26.50	1.10	2.40	2.40	18.00	20000	1.39	B
KW 16B127HP	25.400	12.70	15.88	9.53	7.05	30.80	1.20	4.10	3.10	23.00	40000	2.28	B

# HP chains – design version C

## With simple pitch for standard sprockets

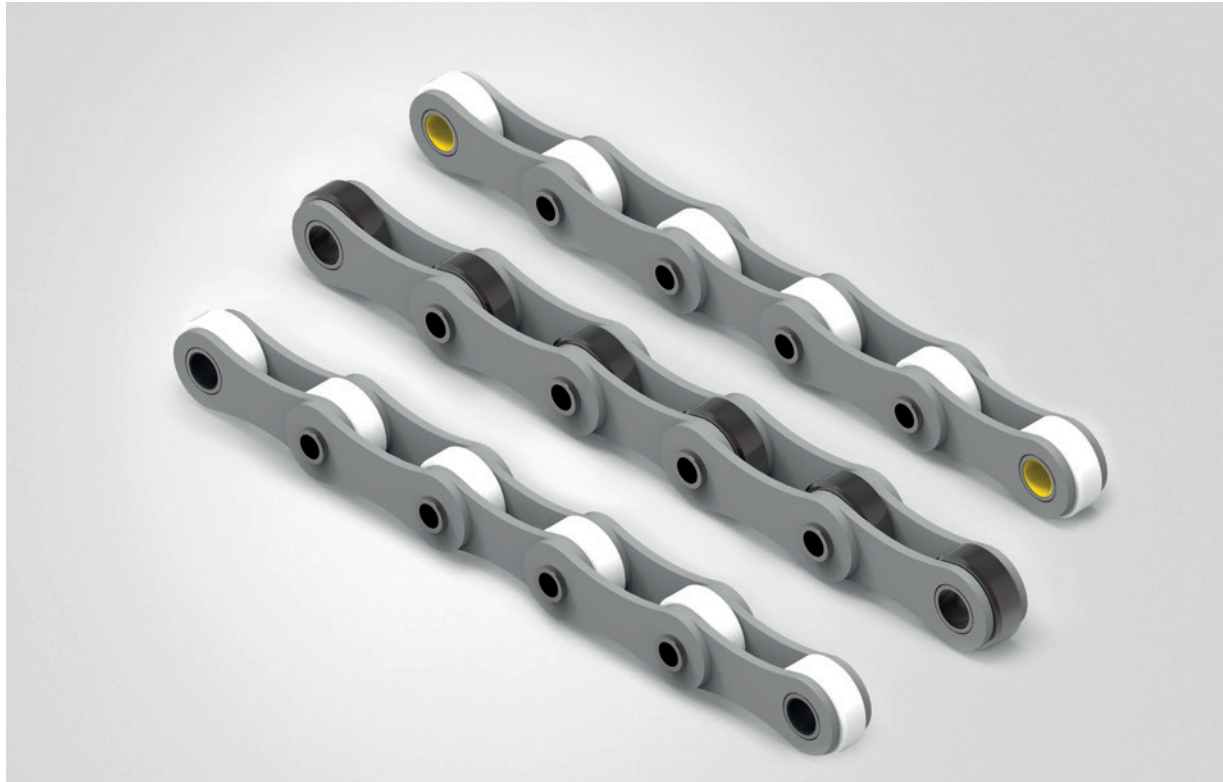
Drawings / product data



KettenWulf gall chains with hollow pins – design version C

KW HP

Designation	Pitch [mm]	Min. inner width [mm]	Max. roller Ø [mm]	Max. pin Ø [mm]	Min. hollow pin internal Ø [mm]	Max. pin length [mm]	Max. overhang connecting pin [mm]	Inner plate thickness [mm]	Outer plate thickness [mm]	Plate height [mm]	Min. breaking load [N]	Weight [kg/m]	Designs
Chain type	p	b <sub>1</sub>	d <sub>4</sub>	d <sub>1</sub>	d <sub>2</sub>	l	k	S <sub>1</sub>	S <sub>2</sub>	σ <sub>g</sub>	F <sub>b</sub>	≈q	
KW 081HB	12.700	3.30	7.75	5.60	4.30	10.20	-	1.30	1.30	10.50	10000	0.35	C
KW 520HB	15.875	6.50	10.16	7.03	5.13	17.70	1.20	2.00	2.00	14.40	17000	0.74	C
KW 10BHB2	15.875	9.50	10.16	7.03	5.00	20.00	1.30	1.88	1.88	14.70	15000	0.92	C
KW 12BHB	19.050	11.86	12.07	8.03	5.20	22.70	1.20	1.85	1.85	15.80	25000	1.10	C



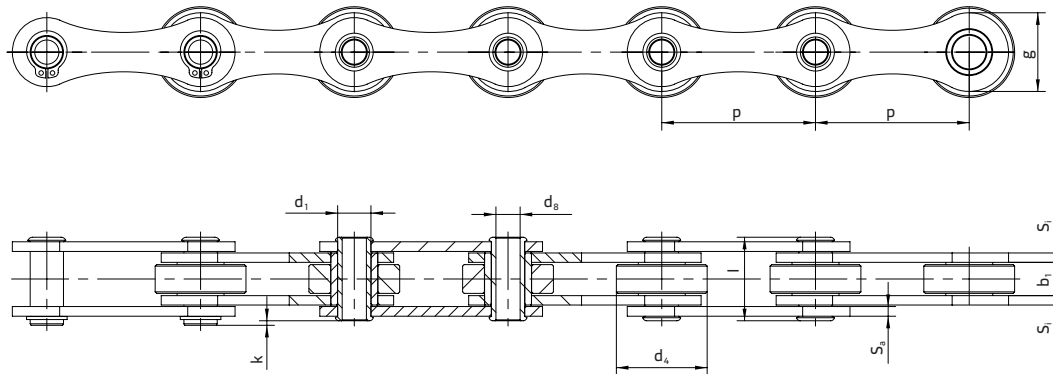
## 1650HP hollow pin chains

The chains of the 1650HP hollow pin chain series all have the same basic dimensions. However, they are manufactured from different materials and their components have received different types of heat and surface treatment. From stock, all chain types are available with a length of 5m. The chains are measured and delivered in pairs. By default, all our coated chains and stainless-steel chains are supplied with FDA H1 lubrication. The seamless bushes and hollow pins are wear-optimised.

# 1650HP hollow pin chains

## Made of different materials & with different surface treatments

Drawings / product data



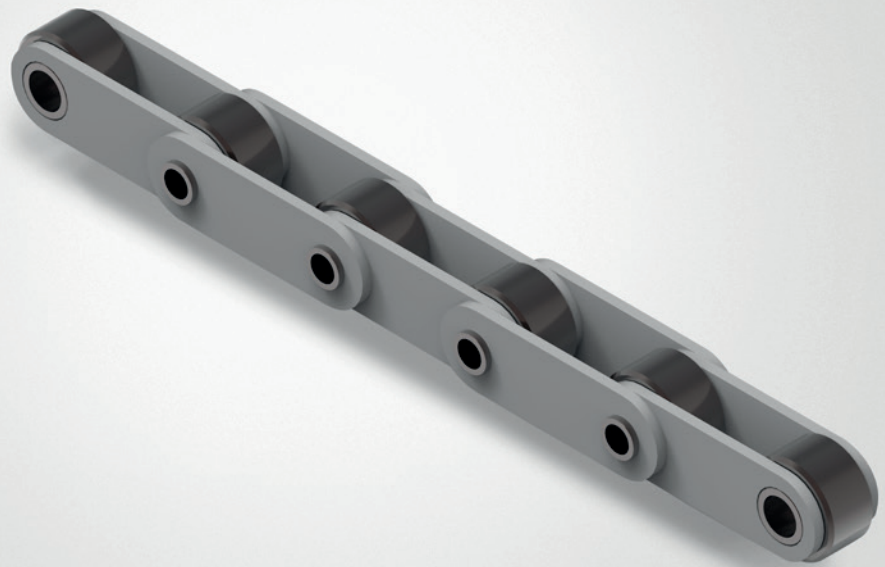
### KettenWulf 1650HP hollow pin chains

#### KW 1650HP

Designation	Pitch [mm]	Min. inner width [mm]	Max. roller Ø [mm]	Max. pin Ø [mm]	Min. hollow pin internal Ø [mm]	Max. pin length [mm]	Max. overhang connecting pin [mm]	Inner plate thickness [mm]	Outer plate thickness [mm]	Plate height [mm]	Min. breaking load [N]	Weight [kg/m]
Chain type	p	b <sub>1</sub>	d <sub>2</sub>	d <sub>1</sub>	d <sub>6</sub>	l	k	S <sub>1</sub>	S <sub>2</sub>	g	F <sub>Br</sub>	≈ q
KW 1650HP	50.800	10.50	30.00	11.40	8.20	27.40	1.20	3.10	3.10	26.00	50000	2.15
KW 16100HP	100.000	10.50	30.00	11.40	8.20	27.40	1.20	3.10	3.10	26.00	50000	1.45
KW 16500HP	50.000	10.50	30.00	11.40	8.20	27.40	1.20	3.10	3.10	26.00	50000	2.15
KW 1650HPZP	50.800	10.50	30.00	11.40	8.20	27.40	1.20	3.10	3.10	26.00	50000	2.15
KW 1650HPZP-D	50.800	10.50	30.00	11.40	8.20	27.40	1.20	3.10	3.10	26.00	50000	1.55
KW 1650HPSS300	50.800	10.50	30.00	11.40	8.20	27.40	1.20	3.10	3.10	26.00	30000	1.55
KW 1650HPSS400	50.800	10.50	30.00	11.40	8.20	27.40	1.20	3.10	3.10	26.00	35000	2.15
KW 1650HPSS400-D	50.800	10.50	30.00	11.40	8.20	27.40	1.20	3.10	3.10	26.00	35000	1.55
KW 1650HPZPK-D	50.800	10.50	30.00	11.40	8.20	27.40	1.20	3.10	3.10	26.00	50000	1.55
KW 1650HPSSK400-D	50.800	10.50	30.00	11.40	8.20	27.40	1.20	3.10	3.10	26.00	50000	1.55

#### Material, heat and surface treatment

Designation	Hollow pin	Bush	Roller	Link plate
KW 1650HP	Case-hardened steel	Case-hardened steel	Case-hardened steel	Heat-treated steel
KW 16100HP	Case-hardened steel	Case-hardened steel	Case-hardened steel	Heat-treated steel
KW 16500HP	Case-hardened steel	Case-hardened steel	Case-hardened steel	Heat-treated steel
KW 1650HPZP	Galvanised case-hardened steel	Galvanised case-hardened steel	Gal. case-hardened steel	Galvanised heat-treated steel
KW 1650HPZP-D	Galvanised case-hardened steel	Galvanised case-hardened steel	Plastic	Galvanised heat-treated steel
KW 1650HPSS300	Stainless SUS 300	Stainless SUS 300	Stainless SUS 300	Stainless SUS 300
KW 1650HPSS400	Tempered stainless SUS 400	Tempered stainless SUS 400	Stainless SUS 300	Stainless SUS 300
KW 1650HPSS400-D	Tempered stainless SUS 400	Tempered stainless SUS 400	Plastic	Stainless SUS 300
KW 1650HPZPK-D	Galvanised case-hardened steel	Galvanised case-hardened steel + thermoplastic slide bearings	Plastic	Galvanised heat-treated steel
KW 1650HPSSK400-D	Tempered stainless SUS 400	Galvanised case-hardened steel + thermoplastic slide bearings	Plastic	Stainless SUS 300



## Double pitch hollow pin (DP-HP) chains

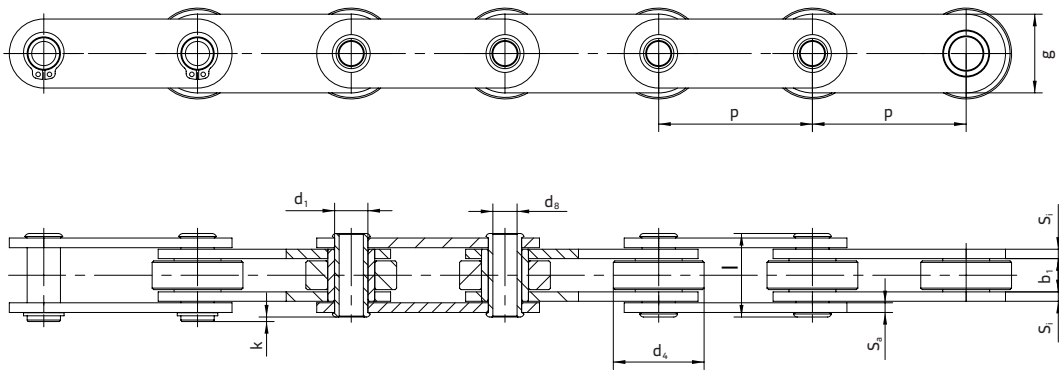
The long-linked KettenWulf DP-HP “double pitch - hollow pin” chains have the same basic dimensions as the KettenWulf HP chains. They are designed with a double pitch and straight link plates. The chains are available with protection rollers or guide rollers.



# DP-HP hollow pin chains

## With double pitch and straight link plates

Drawings / product data



### KettenWulf DP-HP hollow pin chains

#### KW DP-HP

Designation	Pitch [mm]	Min. inner width [mm]	Max. roller Ø [mm]	Max. pin Ø [mm]	Min. hollow pin internal Ø [mm]	Max. pin length [mm]	Max. overhang connecting pin [mm]	Inner plate thickness [mm]	Outer plate thickness [mm]	Plate height [mm]	Min. breaking load [N]	Weight [kg/m]
Chain type	p	b <sub>i</sub>	d <sub>r</sub>	d <sub>1</sub>	d <sub>8</sub>	l	k	S <sub>1</sub>	S <sub>2</sub>	g	F <sub>B</sub>	≈q
KW C2040HP	25.400	7.85	7.95	6.65	4.10	16.50	1.00	1.50	1.50	12.00	11000	0.47
KW C2042HP	25.400	7.85	15.88	5.63	4.00	16.60	0.90	1.50	1.50	12.00	11000	0.82
KW C2050HP	31.750	9.40	10.16	7.03	5.13	20.70	1.20	2.00	2.00	15.09	20000	0.76
KW C2052HP	31.750	9.40	19.05	7.03	5.13	20.70	1.20	2.00	2.00	15.09	20000	1.26
KW C2060HP	38.100	12.70	11.92	8.31	6.10	25.80	1.00	2.40	2.40	18.00	26500	1.12
KW C2062HP	38.100	12.70	22.23	8.31	6.10	25.80	1.00	2.40	2.40	18.00	26500	1.80
KW C2080HP	50.800	15.75	15.88	11.30	8.10	32.40	1.40	3.20	3.20	24.00	51000	1.98
KW C2082HP	50.800	15.75	28.58	11.30	8.10	32.40	1.40	3.20	3.20	24.00	51000	3.20

#### KW DP-HPSS (stainless)

Chain type	p	b <sub>i</sub>	d <sub>r</sub>	d <sub>1</sub>	d <sub>8</sub>	l	k	S <sub>1</sub>	S <sub>2</sub>	g	F <sub>B</sub>	≈q
KW C2042HPSS	25.400	7.95	15.88	5.63	4.10	16.60	0.90	1.50	1.50	12.00	7700	0.82
KW C2052HPSS	31.750	9.53	19.05	7.11	5.10	20.50	1.30	2.00	2.00	15.00	12500	1.26
KW C2062HPSS	38.100	12.70	22.23	8.31	6.10	25.80	1.20	2.40	2.40	18.00	16800	1.80

#### KW 1590HP

Chain type	p	b <sub>i</sub>	d <sub>r</sub>	d <sub>1</sub>	d <sub>8</sub>	l	k	S <sub>1</sub>	S <sub>2</sub>	g	F <sub>B</sub>	≈q
KW 1589HP	38.100	15.20	18.00	14.00	10.20	34.50	1.10	3.70	3.70	27.00	45000	2.62
KW 1598HP	50.000	15.00	26.00	20.10	14.40	32.00	1.50	3.10	3.10	40.00	95000	4.10

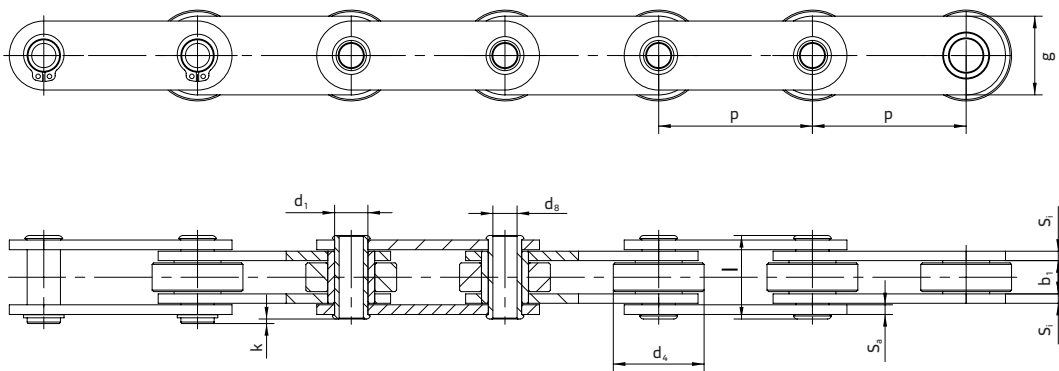


## British Standard hollow pin (BS-HP) chains

KettenWulf BS "British Standard" hollow pin chains are manufactured according to a high quality standard. In order to achieve a higher strength level, the link plates are quenched and tempered and ball blasted. Zinc-plated chains are available upon request.

# BS-HP hollow pin chains

Drawings / product data



## KettenWulf BS-HP hollow pin chains

### KW BS-HP

Designation	Pitch [mm]	Min. inner width [mm]	Max. roller Ø [mm]	Max. bush Ø [mm]	Max. pin Ø [mm]	Min. hollow pin internal Ø [mm]	Max. pin length [mm]	Max. overhang connecting pin [mm]	Inner plate thickness [mm]	Outer plate thickness [mm]	Plate height [mm]	Bearing area [cm <sup>2</sup> ]	Min. breaking load [N]	Weight [kg/m]
Chain type	p	b <sub>1</sub>	d <sub>2</sub>	d <sub>3</sub>	d <sub>1</sub>	d <sub>8</sub>	l	k	S <sub>1</sub>	S <sub>2</sub>	g	f	F <sub>B</sub>	≈ q
KW 4202HP	50.800	15.00	31.80	18.00	14.00	10.10	36.50	2.50	3.80	3.80	25.40	3.20	42000	3.50
KW 4203HP	76.200	15.00	31.80	18.00	14.00	10.10	36.50	2.50	3.80	3.80	25.40	3.20	42000	2.90
KW 4203SHP	88.900	15.00	31.80	18.00	14.00	10.10	36.50	2.50	3.80	3.80	25.40	3.20	42000	2.70
KW 4204HP	101.600	15.00	31.80	18.00	14.00	10.10	36.50	2.50	3.80	3.80	25.40	3.20	42000	2.60
KW 8403HP	76.200	19.05	47.60	23.70	19.05	13.60	43.80	3.00	5.10	3.80	39.00	5.60	84000	6.90
KW 8404HP	101.600	19.05	47.60	23.70	19.05	13.60	43.80	3.00	5.10	3.80	39.00	5.60	84000	5.90
KW 8406HP	152.400	19.05	47.60	23.70	19.05	13.60	43.80	3.00	5.10	3.80	39.00	5.60	84000	4.90

» Partly available as a zinc-plated version from stock upon request.



## Chains for the wood industry

From log transport to sawing to the woodworking industry: In traditional wood-processing the functions provided by the conveyor chains, drive chains and sprockets that are used are often a crucial factor. We can deliver many of these products from stock. This way, you can be sure to be able to restore your plant's availability within the shortest possible time if needed.



# Applications in the log transport sector

Feed conveyor



Butt end reducer/  
cross cut saw



Debarking



Sorting line/  
bloch transport line



Separation/  
log turner





## Chains for log transport

In the field of log transport our products are used in a large variety of sub-processes. Drive chains and conveyor chains transport the round timber in the infeed log conveyor, the butt end reducer, the cross cut saw saw, the debarking, in the sorting line, in the block transport line and during log turning.

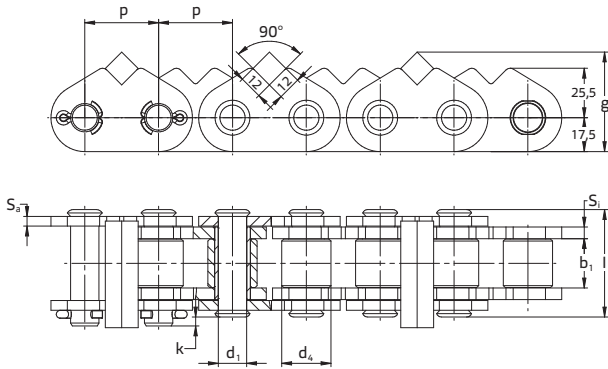
The demands on the products used in these sub-processes are very high and as varied as the individual steps in the work process. The quality of our chains and sprockets, most of which are adapted to the individual requirements of the conveyance task, ensures an optimal service life and extended maintenance intervals.



# Chains for log transport

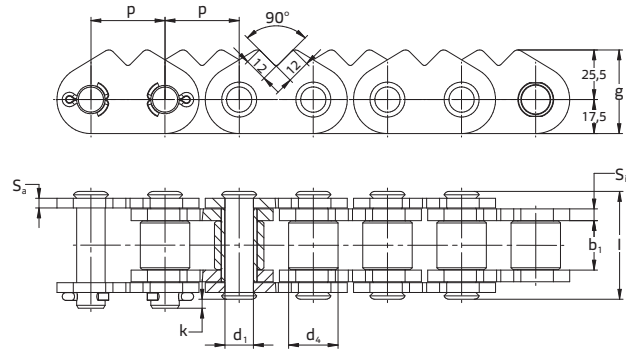
## Roller chains for butt end reducers

Drawings / product data



**KW 24B-1-915**

**1** Roller chains for butt end reducers



**KW 24B-1-1807**

**2** Roller chains for butt end reducers

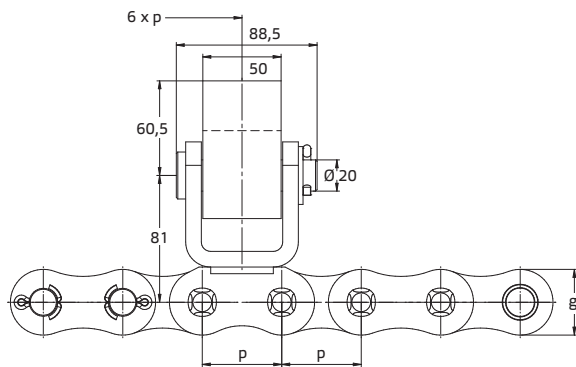
Roller chains for butt end reducers

Figure no.	Designation	Pitch [mm]	Min. inner width [mm]	Max. roller Ø [mm]	Max. pin Ø [mm]	Max. pin length [mm]	Max. connecting pin overhang [mm]	Inner plate thickness [mm]	Outer plate thickness [mm]	Plate height [mm]	Bearing area [cm <sup>2</sup> ]	Min. breaking load [N]	Weight [kg/m]
	Chain type	p	b <sub>1</sub>	d <sub>4</sub>	d <sub>1</sub>	l	k	S <sub>1</sub>	S <sub>2</sub>	g	f	F <sub>B</sub>	≈ q
1	KW 24B-1-915	38.100	25.40	25.40	14.63	54.00	6.60	6.00	5.00	52.00	5.54	160000	11.00
2	KW 24B-1-1807	38.100	25.40	25.40	14.63	54.00	6.60	6.00	5.00	43.00	5.54	160000	8.90

» For welded steel chains for timber transport, refer to page 78

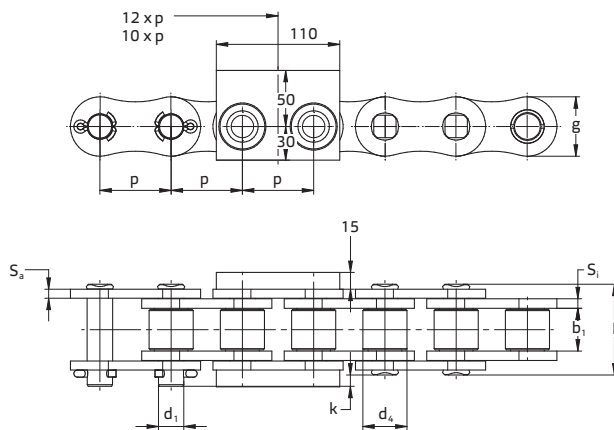
# Chains for log transport

## Drawings



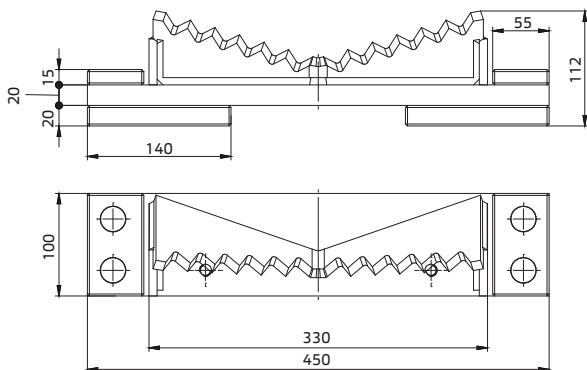
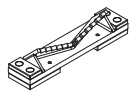
KW 32B-10702

**1** Plastic lugs are available upon request

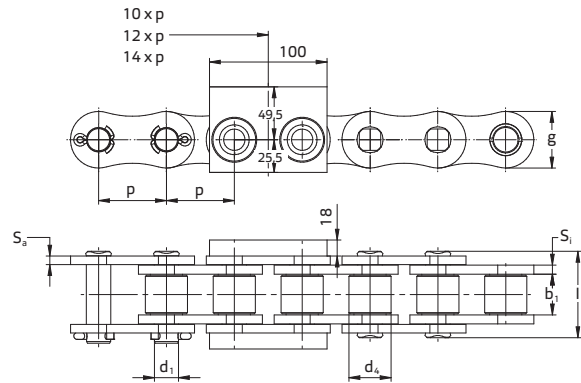


KW 40B-AV1243

**3** Roller chains for probe tip lines and sorting lines

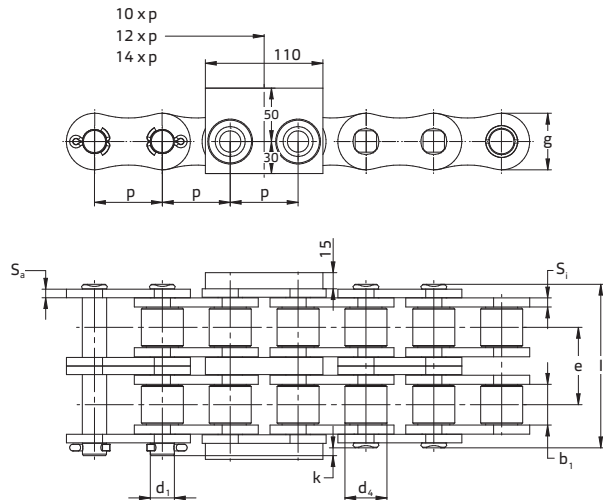


**5** Example of a lug. Lugs are normally designed with induction-hardened sliding surfaces or plastic strips.



KW 32B-AV3386

**2** Roller chains for probe tip lines and sorting lines



KW 40B-2-AV1243

**4** Roller chains for probe tip lines and sorting lines

## Product data

## Chains for log transport

Figure no.	Designation	Pitch [mm]	Min. inner width [mm]	Max. roller Ø [mm]	Max. pin Ø [mm]	Max. pin length [mm]	Max. connecting pin overhang [mm]	Inner plate thickness [mm]	Outer plate thickness [mm]	Plate height [mm]	Transverse pitch [mm]	Bearing area [cm <sup>2</sup> ]	Min. breaking load [N]	Weight [kg/m]
	Chain type	p	b <sub>i</sub>	d <sub>s</sub>	d <sub>i</sub>	l	k	S <sub>i</sub>	S <sub>a</sub>	g	e	f	F <sub>B</sub>	≈ q
1	KW 32B-10702	50.800	31.00	29.21	17.81	66.00	5.00	7.00	6.40	42.00	-	8.10	250000	20.00
2	KW 32B-AV3386	50.800	31.00	29.21	17.81	66.00	5.00	7.00	6.40	42.00	-	8.10	250000	14.00
3	KW 40B-AV1243	63.500	38.10	39.37	22.89	87.00	8.00	8.50	8.00	52.90	-	12.80	355000	21.00
4	KW 40B-2-AV1243	63.500	38.10	39.37	22.89	154.00	8.00	8.50	8.00	52.90	72.29	25.50	710000	38.00

Chains for applications in the sawing line are subject to very high requirements in terms of fatigue strength, such as for the canter infeed



## Chains for the sawing line and wood-board transport

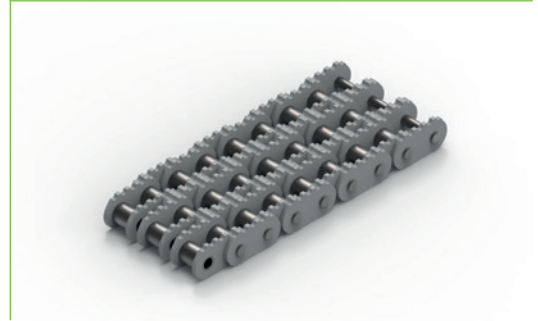
In the wood-processing industry, boards are transported by means of many different types of conveyor systems each of them being adapted to the respective conveyance task. KettenWulf offers a wide range of conveyor chains. The majority of these chains is designed to match the corresponding conveyance task.

Our conveyor chains are used in sawing lines, chipping machine infeed, separation of boards, sorting of boards, storage of boards and palletising.

In order to optimise their fatigue strength the intermediate link plates for multiple-strand chains are designed as block link plates. In addition to that, the pins on chains starting from size 12B have four riveting points.

# Applications in the sawing line and in wood-board transport

Chipper infeed



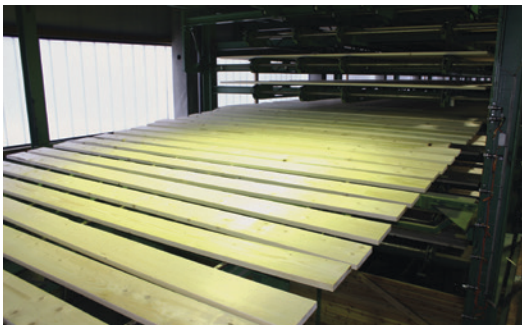
Saw outfeed



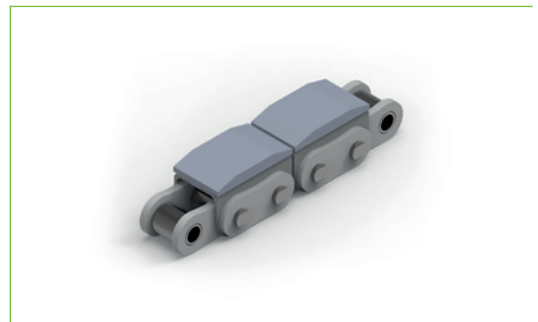
Board separation



Board sorting



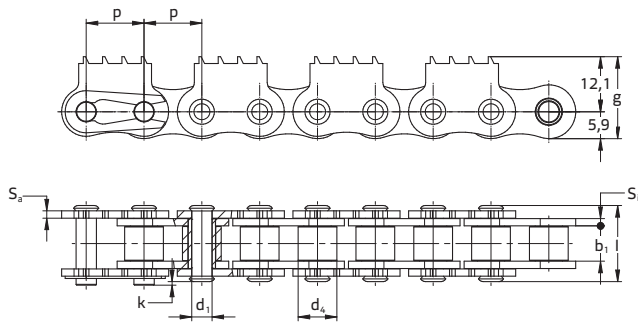
Board storage





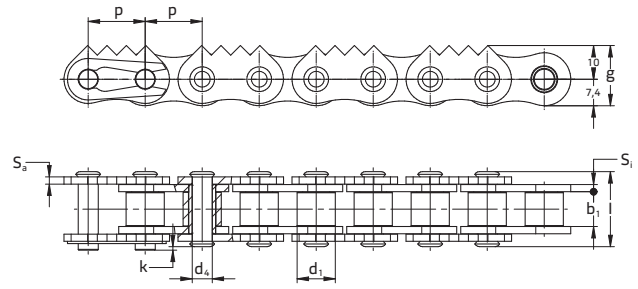
# Chains for sawing lines and wood-board transport

## Drawings



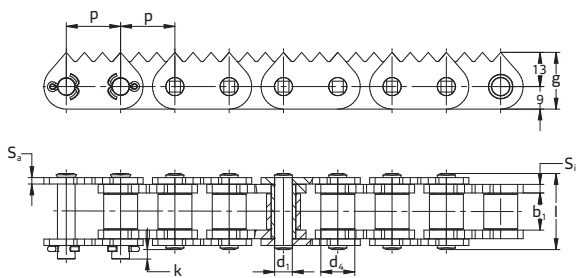
**KW 08B-1-940**

**1** The roller chain 08B is also available as a duplex chain



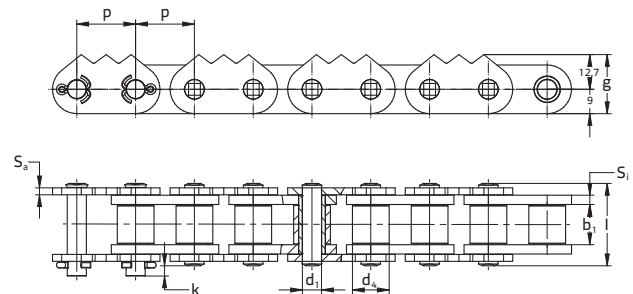
**KW 10B-1-106**

**2** Roller chain 10B with outer link plates with pointed teeth



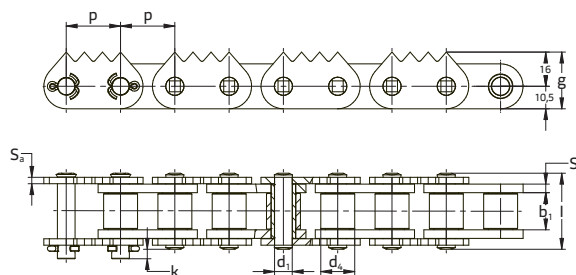
**KW 12B-1-1325 / KW 12B-1-1324**

**3** KW 12B-1-1325 with pointed teeth on the inner and outer link plates  
KW 12B-1-1324 with pointed teeth on the outer plates



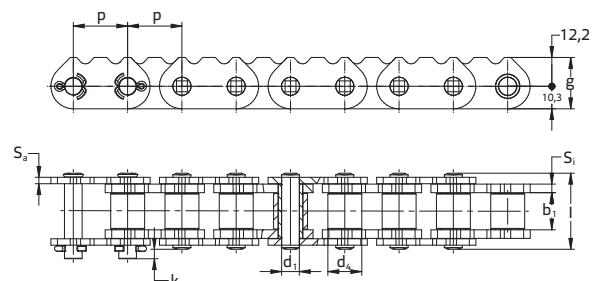
**KW 60-1-910**

**4** The roller chain ASA 60 is also available as a duplex chain



**KW 16B-1-1170**

**5** The roller chain 16B is also available as a duplex or triplex chain



**KW 16B-1-1180**

**6** The roller chain 16B is also available as a duplex or triplex chain



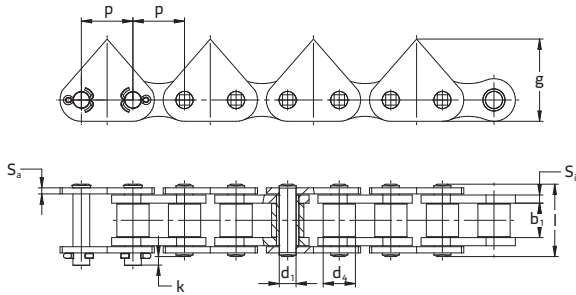
## Product data

## Roller chains

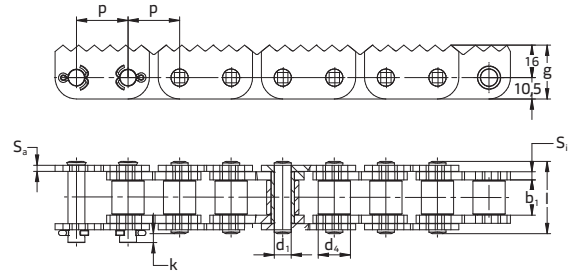
Figure no.	Designation	Pitch [mm]	Min. inner width [mm]	Max. roller Ø [mm]	Max. pin Ø [mm]	Max. pin length [mm]	Max. overhang connecting pin [mm]	Inner plate thickness [mm]	Outer plate thickness [mm]	Plate height [mm]	Transverse pitch [mm]	Bearing area [cm <sup>2</sup> ]	Min. breaking load [N]	Weight [kg/m]
	Chain type	p	b <sub>i</sub>	d <sub>r</sub>	d <sub>p</sub>	l	k	S <sub>i</sub>	S <sub>a</sub>	g	e	f	F <sub>br</sub>	≈ q
1	KW 08B-1-940	12.700	7.75	8.51	4.45	16.70	1.80	1.60	1.60	18.00	-	0.50	18200	0.85
	KW 08B-2-940	12.700	7.75	8.51	4.45	31.20	1.80	1.60	1.60	18.00	13.92	1.01	32000	1.55
2	KW 10B-1-106	15.875	9.65	10.16	5.08	19.00	3.00	1.65	1.65	17.40	-	0.67	22400	1.15
3	KW 12B-1-1324	19.050	11.68	12.07	5.72	22.50	2.60	1.80	1.80	22.00	-	0.89	28900	1.60
3	KW 12B-1-1325	19.050	11.68	12.07	5.72	22.50	2.60	1.80	1.80	22.00	-	0.89	28900	1.60
4	KW 60-1-910	19.050	12.70	11.91	5.95	25.20	2.30	2.40	2.40	21.70	-	1.05	31800	1.65
	KW 60-2-910	19.050	12.70	11.91	5.95	49.00	2.30	2.40	2.40	21.70	22.80	2.10	62500	3.30
5	KW 16B-1-1170	25.400	17.02	15.88	8.28	36.00	3.60	4.20	3.10	26.50	-	2.10	60000	2.90
	KW 16B-2-1170	25.400	17.02	15.88	8.28	68.00	3.60	4.20	3.10	26.50	31.88	4.21	106000	5.80
	KW 16B-3-1170	25.400	17.02	15.88	8.28	100.00	3.60	4.20	3.10	26.50	31.88	6.31	166000	8.40
6	KW 16B-1-1180	25.400	17.02	15.88	8.28	36.00	3.60	4.20	3.10	22.50	-	2.10	60000	2.90
	KW 16B-2-1180	25.400	17.02	15.88	8.28	68.00	3.60	4.20	3.10	22.50	31.88	4.21	106000	5.80
	KW 16B-3-1180	25.400	17.02	15.88	8.28	100.00	3.60	4.20	3.10	22.50	31.88	6.31	166000	8.40

# Chains for sawing lines and wood-board transport

## Drawings

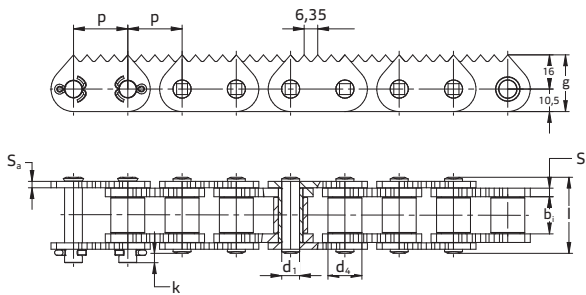


**1** KW 16B1502P – with special plate on every outer link  
KW 16B1504P – with special plate on every 2nd outer link

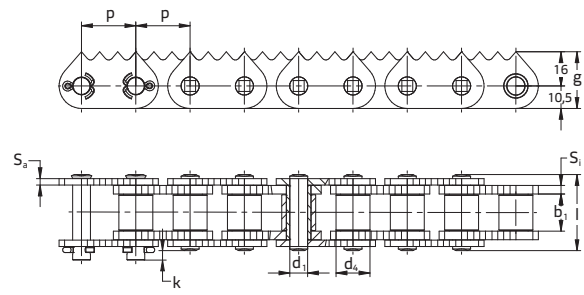


**KW 16B-1-1186**

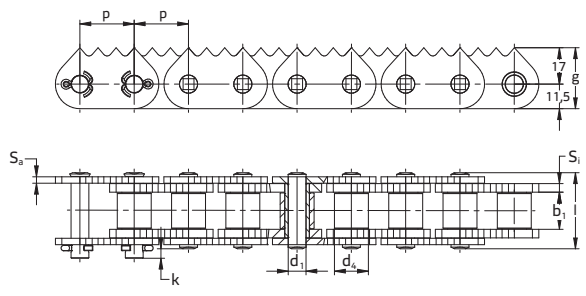
**2** The roller chain 16B is also available as a duplex or triplex chain



**3** KW 16B-1-1125

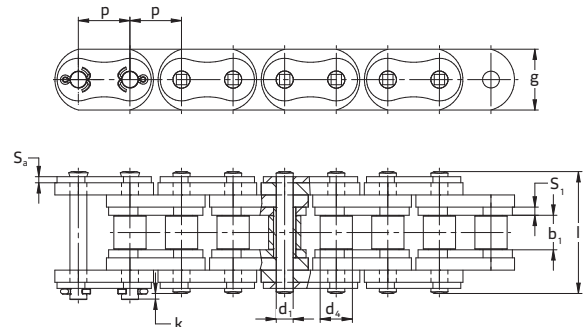


**4** KW 16B-1-1230



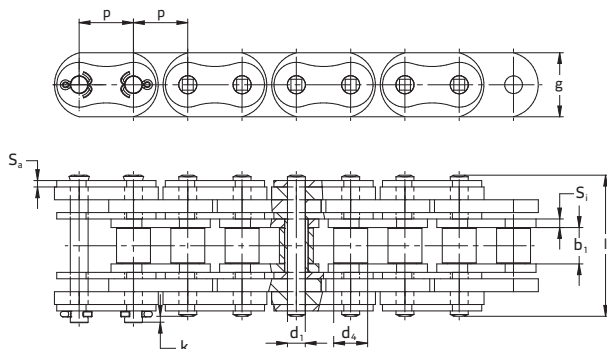
**KW 80-1-1230**

**5** The roller chain ASA 80 is also available as a duplex or triplex chain



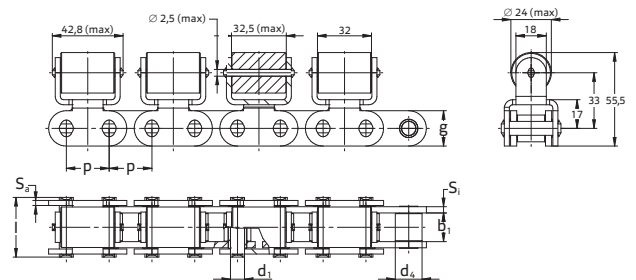
**KW 16BNMC09 / KW 16BNMC07\***

**6** Roller chain 16B with plastic link plates made of PA6 on the inner and outer links  
\* KW 16BNMC07 – with additional plastic plates made of PA6 only on the inner link



**KW 16BNMC19**

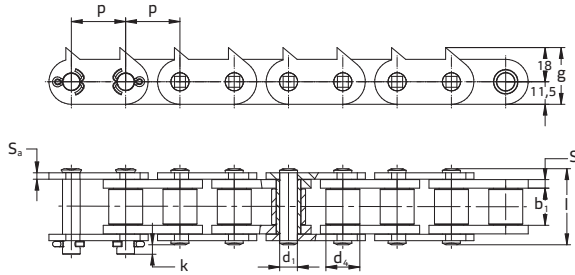
**7** Roller chain 16B with plastic link plates made of PA6



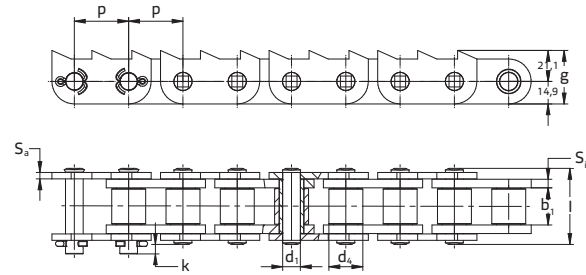
**KW 16B TRR24352P**

**8** Roller chain 16B with top roller

Drawings / product data



KW 80-1-1274



KW 100-1-1200

9 The roller chain ASA 80 is also available as a duplex or triplex chain

10 The roller chain ASA 100 is also available as a duplex or triplex chain

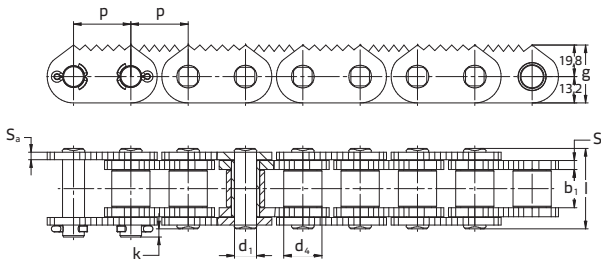
Roller chains for sawing lines and wood-board transport

Figure no.	Designation	Pitch [mm]	Min. inner width [mm]	Max. roller Ø [mm]	Max. pin Ø [mm]	Max. pin length [mm]	Max. overhang connecting pin [mm]	Inner plate thickness [mm]	Outer plate thickness [mm]	Plate height [mm]	Transverse pitch [mm]	Bearing area [cm <sup>2</sup> ]	Min. breaking load [N]	Weight [kg/m]
	Chain type	p	b <sub>1</sub>	d <sub>2</sub>	d <sub>1</sub>	l	k	S <sub>i</sub>	S <sub>a</sub>	g	e	f	F <sub>B</sub>	≈q
1	KW 16B1502P	25.400	17.02	15.88	8.28	36.00	3.30	4.20	3.10	40.50	-	2.10	60000	3.00
	KW 16B1504P	25.400	17.02	15.88	8.28	36.00	3.60	4.20	3.10	40.50	-	2.10	60000	2.90
2	KW 16B-1-1186	25.400	17.02	15.88	8.28	36.00	3.30	4.20	3.10	26.50	-	2.10	60000	3.00
	KW 16B-2-1186	25.400	17.02	15.88	8.28	68.00	3.30	4.20	3.10	26.50	31.88	4.21	106000	6.00
	KW 16B-3-1186	25.400	17.02	15.88	8.28	100.00	3.30	4.20	3.10	26.50	31.88	6.31	160000	9.00
3	KW 16B-1-1125	25.400	17.02	15.88	8.28	36.00	3.30	4.20	3.10	26.50	-	2.10	60000	3.00
4	KW 16B-1-1230	25.400	17.02	15.88	8.28	36.00	6.30	4.20	3.10	26.50	-	2.10	60000	3.00
5	KW 80-1-1230	25.400	15.88	15.88	7.93	33.00	3.90	3.20	3.20	28.50	-	1.77	73500	1.85
	KW 80-2-1230	25.400	15.88	15.88	7.93	61.80	3.90	3.20	3.20	28.50	29.30	3.54	147000	3.70
	KW 80-3-1230	25.400	15.88	15.88	7.93	91.20	3.90	3.20	3.20	28.50	29.30	5.31	220500	5.60
6	KW 16BNMC07	25.400	17.02	15.88	8.28	48.00	3.00	4.00	3.00	30.00	-	2.10	40000	3.00
6	KW 16BNMC09	25.400	17.02	15.88	8.28	62.00	3.30	4.20	3.10	30.00	-	2.10	27000	3.20
7	KW 16BNMC19	25.400	17.02	15.88	8.28	68.00	3.30	4.20	3.10	30.00	-	2.10	60000	3.30
8	KW 16B TRR24352P	25.400	17.02	15.88	8.28	62.00	3.30	4.00	3.00	21.00	-	2.10	60000	6.50
9	KW 80-1-1274	25.400	15.88	15.88	7.93	33.00	3.80	3.20	3.20	29.50	-	1.77	73500	2.95
	KW 80-2-1274	25.400	15.88	15.88	7.93	61.80	3.80	3.20	3.20	29.50	29.30	3.54	147000	5.70
	KW 80-3-1274	25.400	15.88	15.88	7.93	91.20	3.80	3.20	3.20	29.50	29.30	5.31	220500	8.60
10	KW 100-1-1200	31.750	19.05	19.05	9.53	34.90	4.00	4.00	4.00	36.00	-	2.58	87000	4.50
	KW 100-2-1200	31.750	19.05	19.05	9.53	75.00	4.00	4.00	4.00	36.00	35.80	5.16	174000	9.50
	KW 100-3-1200	31.750	19.05	19.05	9.53	111.00	4.00	4.00	4.00	36.00	35.80	7.73	261000	14.00

# Chains for sawing lines and wood-board transport

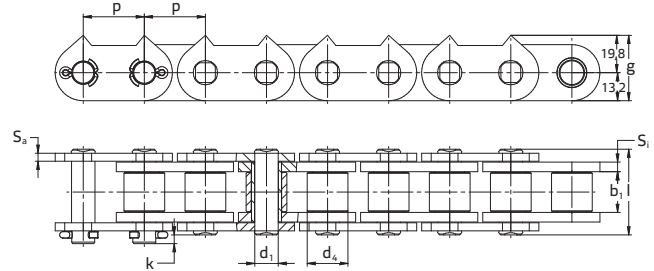
## Roller chains with toothed link plates

### Drawings



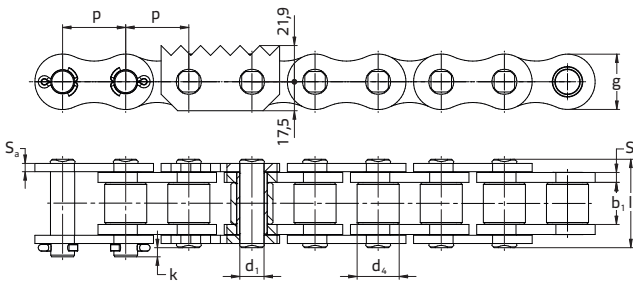
KW 20B-1-1310

**1** Roller chain 20B with inner and outer link plates with pointed teeth



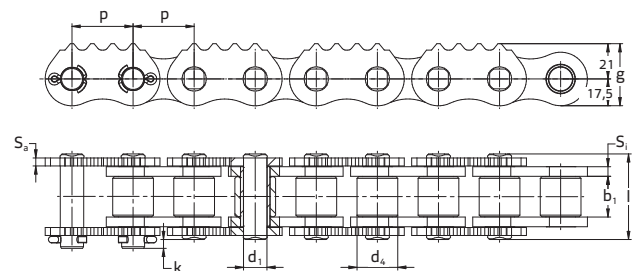
KW 20B-1-1350

**2** Roller chain 20B with two teeth; also available as a duplex chain



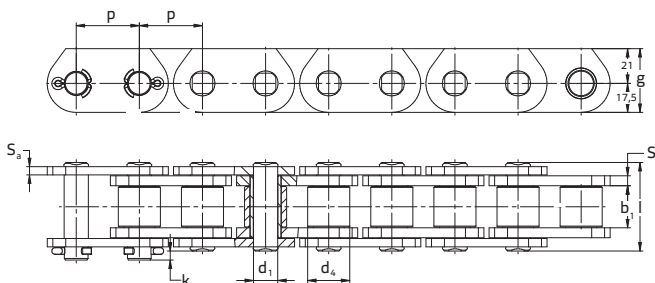
KW 24B-1-1186

**3** Roller chain 24B with outer link plates with teeth  
Toothed outer link spacing according to customer demand



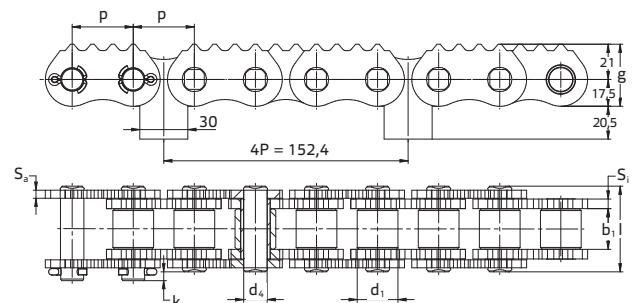
KW 24B-1-1794

**4** Roller chain 24B with outer link plates with blunt teeth;  
also available as a duplex chain



KW 24B-1-1805

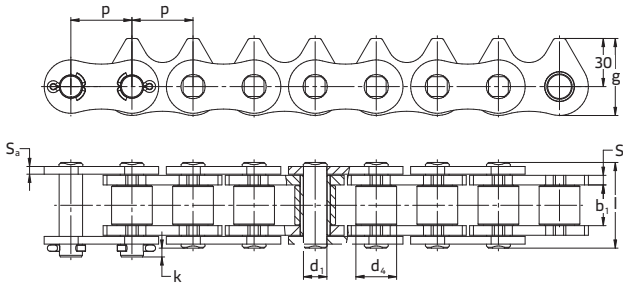
**5** Roller chain 24B with deep links



KW 24B-1-1809

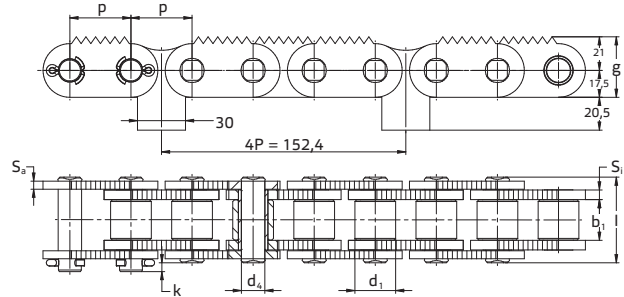
**6** Roller chain 24B with outer link plates with blunt teeth; every  
second inner link has a guide lug

Drawings / product data



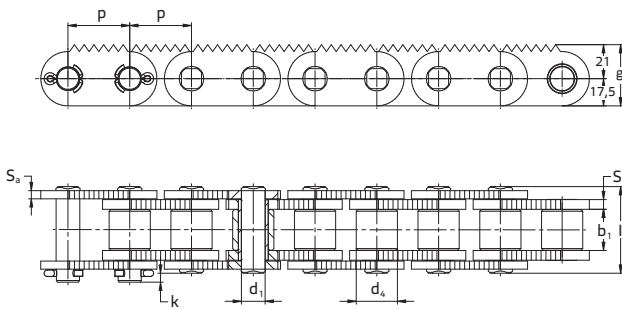
KW 24B-1-1810

7 Roller chain 24B with 60° blunt teathed inner link plates



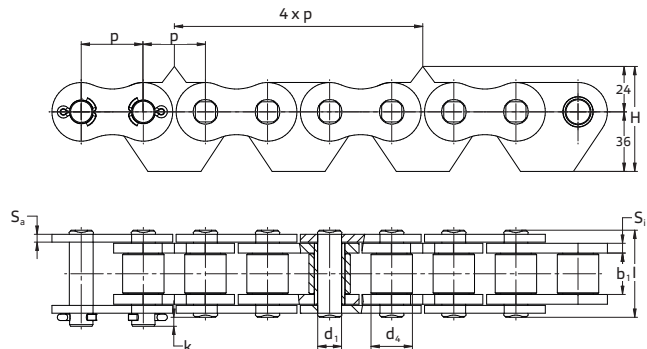
KW 24B-1-1811

8 Roller chain 24B with link plates with pointed teeth every second inner link has a guide lug



KW 24B-1-1820

9 Roller chain 24B with inner and outer link plates with pointed teeth also available as a duplex chain



KW 24B-1-1830

10 Roller chain 24B with inner and outer link plates with pointed teeth also available as a duplex chain

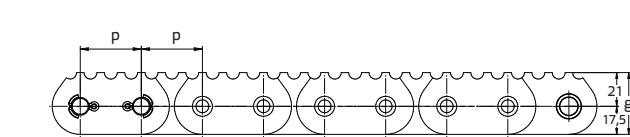
Roller chains with toothed link plates

Figure no.	Designation	Pitch [mm]	Min. inner width [mm]	Max. roller Ø [mm]	Max. pin Ø [mm]	Max. pin length [mm]	Max. overhang connecting pin [mm]	Inner plate thickness [mm]	Outer plate thickness [mm]	Plate height [mm]	Transverse pitch [mm]	Bearing area [cm <sup>2</sup> ]	Min. breaking load [N]	Weight [kg/m]
	Chain type	p	b <sub>i</sub>	d <sub>e</sub>	d <sub>i</sub>	l	k	S <sub>i</sub>	S <sub>e</sub>	g	e	f	F <sub>B</sub>	≈ q
1	KW 20B-1-1310	31.750	19.56	19.05	10.19	41.00	3.40	4.50	3.50	33.00	-	2.96	95000	5.00
	KW 20B-2-1310	31.750	19.56	19.05	10.19	77.20	3.40	4.50	3.50	33.00	36.45	5.92	170000	9.80
2	KW 20B-1-1350	31.750	19.56	19.05	10.19	41.00	3.40	4.50	3.50	33.00	-	2.96	95000	4.60
	KW 20B-2-1350	31.750	19.56	19.05	10.19	77.20	3.40	4.50	3.50	33.00	36.45	5.92	170000	9.00
3	KW 24B-1-1186	38.100	25.40	25.40	14.63	54.00	4.70	6.00	4.80	38.50	-	5.54	160000	9.10
4	KW 24B-1-1794	38.100	25.40	25.40	14.63	54.00	4.70	6.00	4.80	38.50	-	5.54	160000	8.60
	KW 24B-2-1794	38.100	25.40	25.40	14.63	101.00	4.70	6.00	4.80	38.50	48.36	11.09	280000	17.20
5	KW 24B-1-1805	38.100	25.40	25.40	14.63	54.00	4.70	6.00	4.80	38.50	-	6.54	160000	9.40
6	KW 24B-1-1809	38.100	25.40	25.40	14.63	54.00	4.70	6.00	4.80	38.50	-	5.54	160000	8.90
7	KW 24B-1-1810	38.100	25.40	25.40	14.63	53.30	4.70	6.00	4.80	46.50	-	5.54	160000	10.00
8	KW 24B-1-1811	38.100	25.40	25.40	14.63	54.00	4.70	6.00	4.80	38.50	-	5.54	160000	9.00
9	KW 24B-1-1820	38.100	25.40	25.40	14.63	54.00	4.70	6.00	4.80	38.50	-	5.54	160000	9.10
	KW 24B-2-1820	38.100	25.40	25.40	14.63	101.00	4.70	6.00	4.80	38.50	48.36	11.09	280000	18.00
10	KW 24B-1-1830	38.100	25.40	25.40	14.63	54.00	4.70	6.00	4.80	38.50	-	5.54	160000	9.20

# Chains for sawing lines and wood-board transport

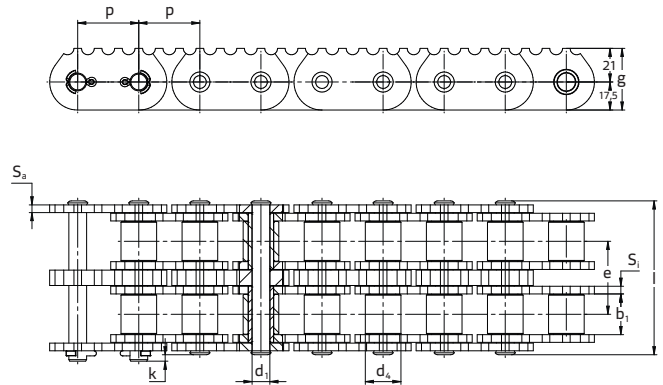
## Roller chains with toothed link plates

### Drawings



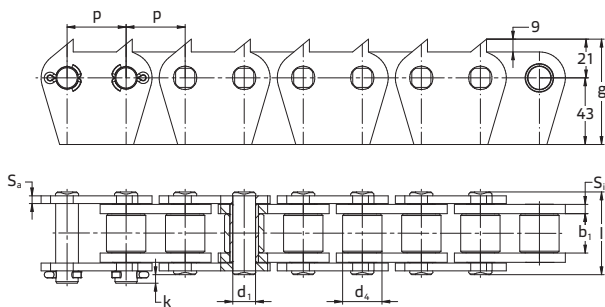
KW 120-1-1802

- 1** Chipper infeed chains with inner and outer link plates with blunt teeth; also available as a triplex chain



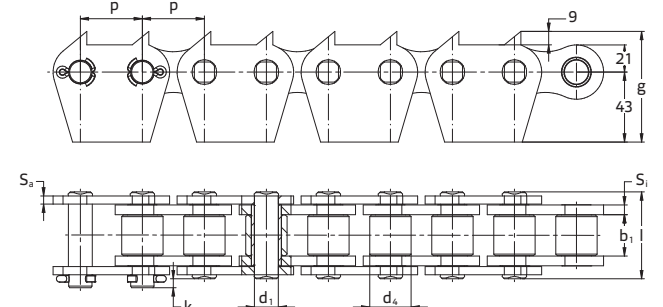
KW 120-2-1802

- 2** Chipper infeed chains with inner and outer link plates with blunt teeth; also available as a triplex chain



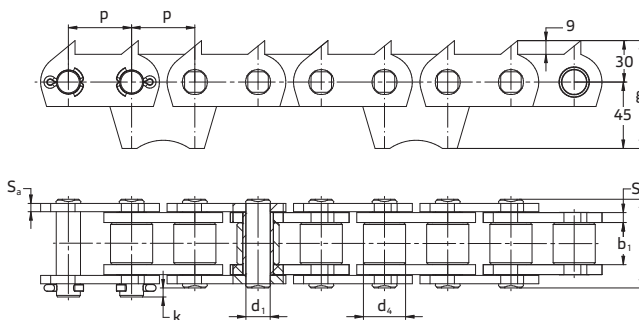
KW 32B-1-1872

- 3** Toothed roller chain 32B with increased inner width



KW 32B-1-1874

- 4** Roller chain with toothed special outer link plates



KW 32B-1-1890

- 5** Roller chain 32B with outer link plates with pointed teeth; every second inner link has a guide lug



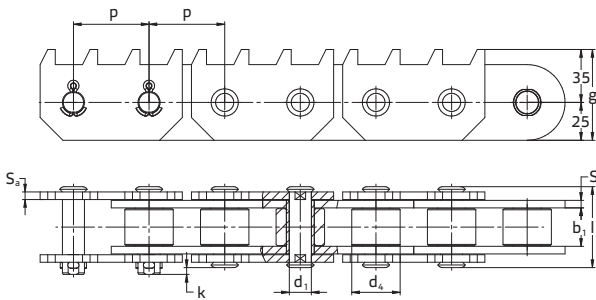
## Product data

## Roller chains with toothed link plates

Figure no.	Designation	Pitch [mm]	Min. inner width [mm]	Max. roller Ø [mm]	Max. pin Ø [mm]	Max. pin length [mm]	Max. overhang connecting pin [mm]	Inner plate thickness [mm]	Outer plate thickness [mm]	Plate height [mm]	Transverse pitch [mm]	Bearing area [cm <sup>2</sup> ]	Min. breaking load [N]	Weight [kg/m]
	Chain type	p	b <sub>i</sub>	d <sub>a</sub>	d <sub>p</sub>	l	k	S <sub>i</sub>	S <sub>a</sub>	g	e	f	F <sub>a</sub>	≈ q
1	KW 120-1-1802	38.100	25.40	22.23	11.10	50.00	4.00	4.80	4.80	38.50	-	3.89	124600	6.90
2	KW 120-2-1802	38.100	25.40	22.23	11.10	96.00	4.00	4.80	4.80	38.50	45.44	7.78	250000	13.80
	KW 120-3-1802	38.100	25.40	22.23	11.10	141.00	4.00	4.80	4.80	38.50	45.44	11.66	375000	20.70
3	KW 32B-1-1872	50.800	33.00	29.21	17.81	66.00	5.00	6.00	6.00	73.00	-	8.10	250000	13.50
4	KW 32B-1-1874	50.800	31.00	29.21	17.81	66.00	5.00	7.00	6.00	73.00	-	8.10	250000	12.00
5	KW 32B-1-1890	50.800	31.00	29.21	17.81	66.00	5.00	7.00	6.00	75.00	-	8.90	250000	12.50

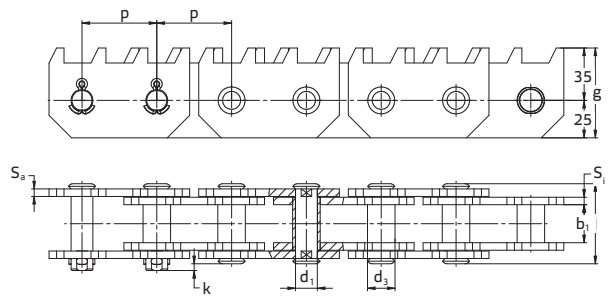
# Chains for sawing lines and wood-board transport

## Drawings



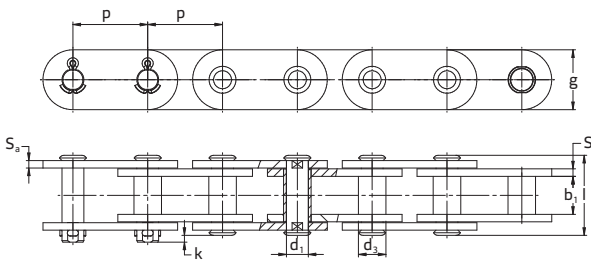
**KW 500-1860**

**1** Infeed chain for chipping headrig with toothed outer link plate



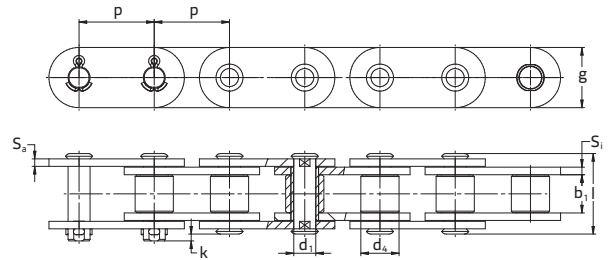
**KW 500-1870**

**2** Infeed chain for chipping headrig with toothed inner and outer link plate



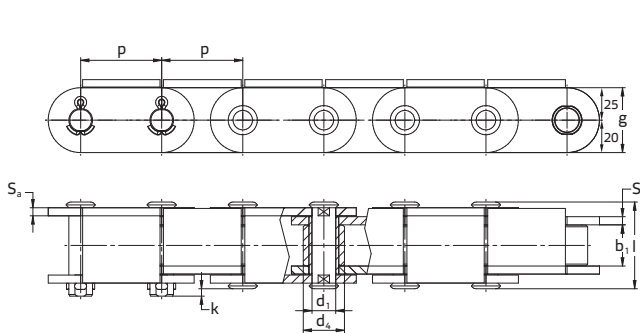
**KW 500 / KW 441100**

**3** Chains available with 50mm and 100mm pitch; link plates with full radius



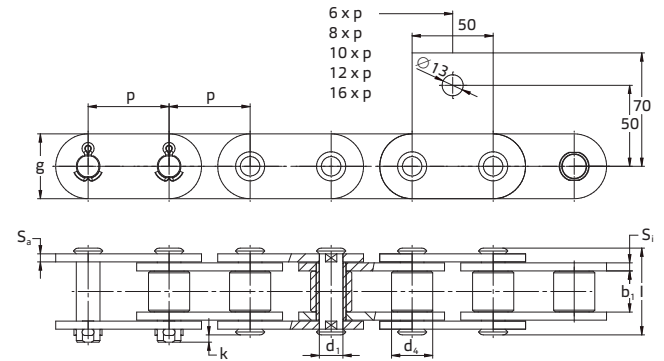
**KW 500SR / KW 44100SR**

**4** Chains available with 50mm and 100mm pitch; link plates with full radius



**KW 500SRCT1**

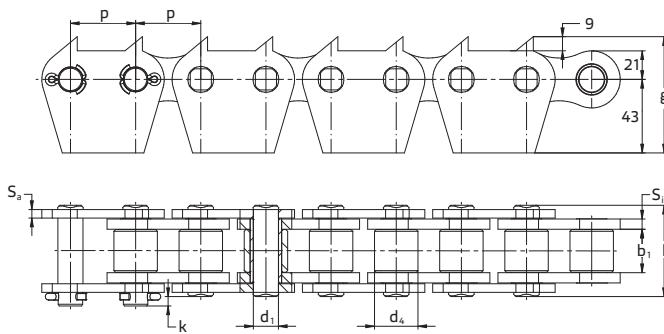
**5** Deep link chain with bent inner and outer link plates on alternating sides



**KW 500SRSK-1**

**6** Bush conveyor chain available with different lug spacings

Drawings / product data



KW 508-1900

7 Infeed chain for chipping headrig with toothed outer link plate

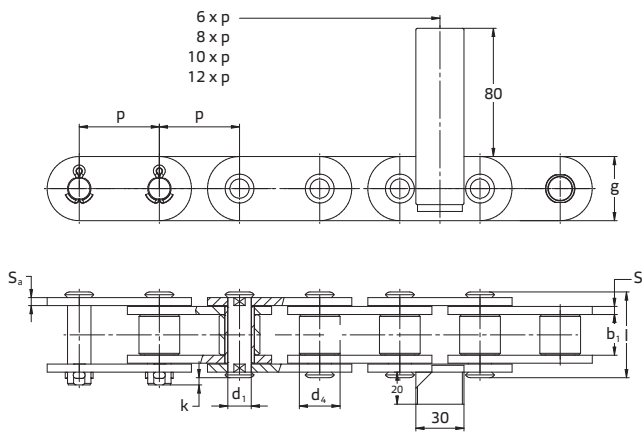
Chains for sawing lines and wood-board transport

Figure no.	Designation	Pitch [mm]	Min. inner width [mm]	Max. roller Ø [mm]	Max. pin Ø [mm]	Max. pin length [mm]	Max. overhang connecting pin [mm]	Inner plate thickness [mm]	Outer plate thickness [mm]	Plate height [mm]	Bearing area [cm <sup>2</sup> ]	Min. breaking load [N]	Weight [kg/m]
	Chain type	p	b <sub>1</sub>	d <sub>2</sub>	d <sub>1</sub>	l	k	S <sub>1</sub>	S <sub>2</sub>	g	f	F <sub>B</sub>	≈ q
1	KW 500-1860	50.000	40.00	32.00	16.00	65.00	5.00	8.00	8.00	60.00	8.90	220000	16.00
2	KW 500-1870	50.000	40.00	32.00	16.00	65.00	5.00	8.00	8.00	60.00	5.90	220000	16.30
3	KW 500	50.000	25.00	20.00	14.00	54.00	3.00	5.00	5.00	40.00	4.90	99000	7.22
3	KW 441100	100.000	25.00	20.00	14.00	54.00	3.00	5.00	5.00	40.00	4.90	99000	5.18
4	KW 500SR*	50.000	25.40	25.40	14.63	55.00	3.00	5.00	5.00	40.00	5.30	100000	7.20
4	KW 500SRBFK**	50.000	25.40	25.40	14.63	55.00	3.00	5.00	5.00	40.00	5.30	100000	7.20
4	KW 500SRHT***	50.000	25.40	25.40	14.63	55.00	3.00	5.00	5.00	40.00	5.30	160000	7.20
4	KW 441100SR	100.000	25.40	25.40	14.63	55.00	3.00	5.00	5.00	40.00	5.30	108000	5.55
5	KW 500SRCT1	50.000	25.40	25.40	14.63	55.00	3.00	5.00	5.00	40.00	5.30	108000	8.00
6	KW 500RSK-1	50.000	25.40	25.40	14.63	55.00	3.00	5.00	5.00	40.00	5.30	108000	7.50
7	KW 508-1900	50.800	17.00	29.40	17.81	52.00	3.00	7.00	6.00	73.00	5.50	255000	16.00

\* roller chain basis – untreated link plates  
 \*\* bush conveyor chain basis – untreated link plates  
 \*\*\* roller chain basis – heat-treated link plates

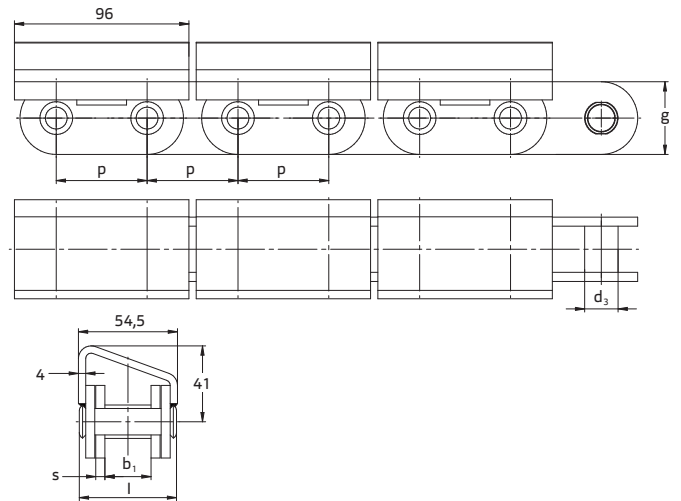
# Chains for sawing lines and wood-board transport

## Drawings



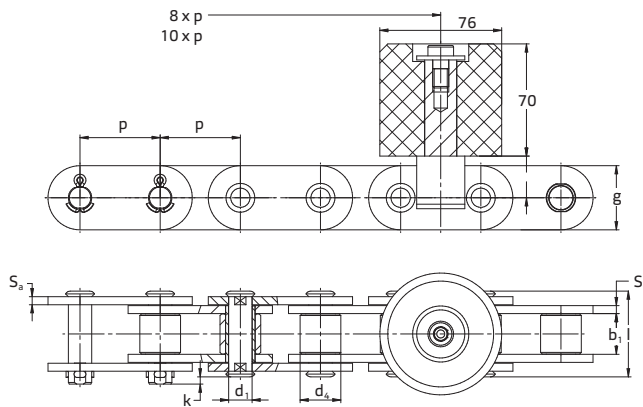
**KW 500SRKMF1**

**1** Lug can be chamfered on the inside and the outside upon request



**KW 500HMB21**

**2** Different versions with and without anti-wear rollers available



**KW 500SRFRK**

**3** Chains with different lug spacings – available with and without plastic rollers

## Product data

## Chains for sawing lines and wood-board transport

Figure no. Designation	Pitch [mm]	Min. inner width [mm]	Max. bush or roller Ø [mm]	Max. pin Ø [mm]	Max. pin length [mm]	Max. overhang connecting pin [mm]	Plate thickness [mm]	Plate height [mm]	Bearing area [cm <sup>2</sup> ]	Min. breaking load [N]	Weight [kg/m]
Chain type	p	b <sub>i</sub>	d <sub>3</sub> /d <sub>4</sub>	d <sub>1</sub>	l	k	S <sub>1</sub> /S <sub>a</sub>	g	f	F <sub>B</sub>	≈ q
KW 500KMF1*	50.000	25.00	20.00	14.00	54.00	3.00	5.00/5.00	40.00	4.90	99000	9.50
1 KW 500SRKMF1	50.000	25.40	25.40	14.63	55.00	3.00	5.00/5.00	40.00	5.30	108000	10.00
2 KW 500HMB21	50.000	25.00	20.00	14.00	54.00	3.00	5.00/5.00	40.00	4.90	99000	10.00
KW 500FRK*	50.000	25.00	20.00	14.00	54.00	3.00	5.00/5.00	40.00	4.90	99000	7.00
3 KW 500SRFRK	50.000	25.40	25.40	14.63	55.00	3.00	5.00/5.00	40.00	5.30	108000	8.00

\* without roller



## Chains for the wood-processing industry

KettenWulf also offers special and standard solutions for your conveyance tasks in the wood-processing industry. Our know-how and long-standing experience in this field allows us to develop chain designs which are tailored to your specific application.

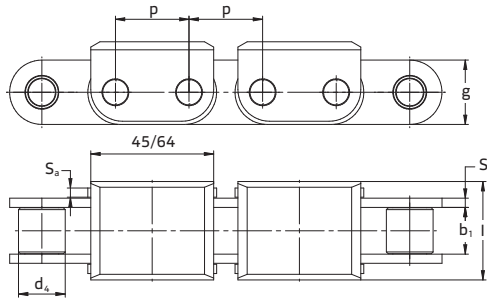
Together with you, our experienced engineers will develop the optimum solution for your application. Our products can be used in almost all areas related to the wood-processing industry, such as:

- » chipboard industry
- » furniture industry
- » glued laminated timber industry
- » paper and cellulose industry
- » planing mills
- » wood profiling machines



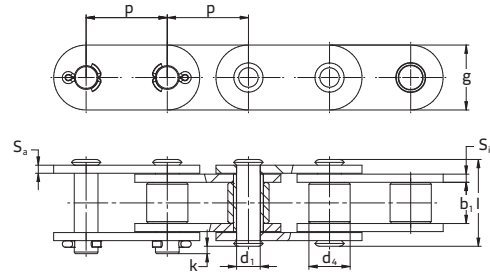
# Chains for the wood-processing industry

Drawings / product data



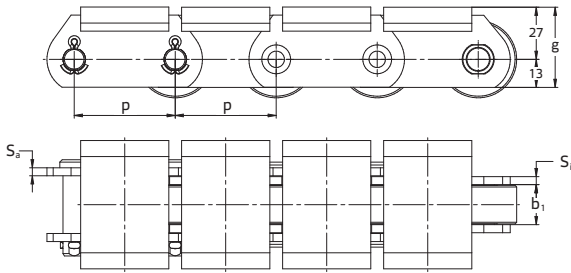
**KW C16B24TPG / KW C20BTPG**

**1** The plastic clips made of PA6 can also be purchased separately



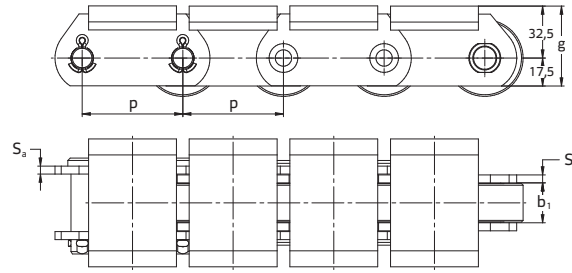
**KW 81X / KW 81HX / KW 81HHX**

**2** Roller chain KW 81X is also available in a reinforced version



**KW 4095**

**3** Deep link chain with welded supporting plates



**KW 4098**

**4** Deep link chain with welded supporting plates

Chains for the wood-processing industry

Figure no.	Designation	Pitch [mm]	Min. inner width [mm]	Max. bush or roller Ø [mm]	Max. pin Ø [mm]	Max. pin length [mm]	Max. connecting pin overhang [mm]	Plate thickness [mm]	Plate height [mm]	Bearing area [cm <sup>2</sup> ]	Min. breaking load [N]	Weight [kg/m]
	Chain type	p	b <sub>1</sub>	d <sub>s</sub>	d <sub>1</sub>	l	k	S <sub>1</sub> /S <sub>a</sub>	g	f	F <sub>B</sub>	≈ q
1	KW C16B24TPG	25.400	17.02	15.88	8.28	42.00	3.30	4.20/3.10	24.00	2.10	60000	3.20
1	KW C20BTPG	31.750	19.56	19.05	10.19	47.00	3.40	4.50/3.50	26.00	2.96	95000	4.60
2	KW 81X	66.270	27.00	23.00	11.10	49.00	5.00	4.00/4.00	28.50	3.90	106700	3.80
2	KW 81HX	66.270	27.80	23.00	11.10	61.00	5.00	7.50/5.60	31.50	4.90	152000	5.80
2	KW 81HHX (XHD)	66.270	27.80	23.00	11.10	66.00	4.00	7.50/7.50	31.50	4.90	186700	6.70
3	KW 4095	40.000	18.00	32.00	10.00	36.00	4.00	3.00	40.00	2.40	40000	7.40
	KW 4096	50.000	15.00	31.00	10.00	36.00	4.00	4.00	30.00	4.90	50000	6.50
4	KW 4098	63.000	25.00	48.00	14.00	53.00	6.00	5.00	50.00	4.90	140000	14.00



## Spare parts

As a supplement to our extensive range of chains, KettenWulf also offers the corresponding accessories for all types of chains.

In addition to the connecting links and spare parts for the chains shown in our catalogue, assembling tools and high-grade lubricants for various different fields of application complete the KettenWulf product portfolio.

## Standard packing units – strand lengths of the roller chains



### Box (meters)

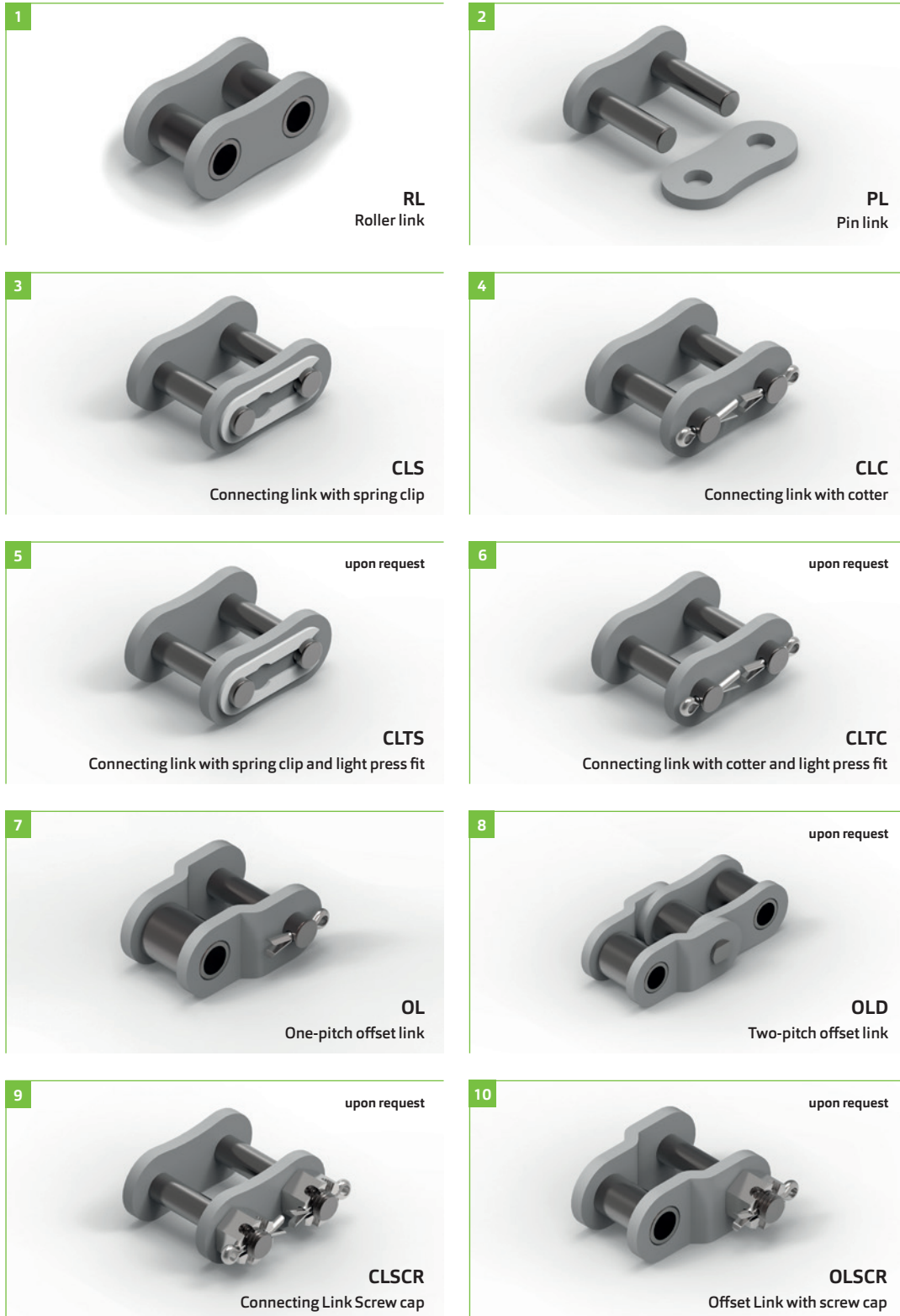
Pitch		Simplex		Duplex		Triplex	
		Content: Number of meters including 2 CL		Content: Number of meters including 2 CL		Content: Number of meters including 2 CL	
mm	inch	Links	Length	Links	Length	Links	Length
6.000	-	831 + 2 CL	4.998 m	831 + 2 CL	4.998 m	831 + 2 CL	4.998 m
6.350	1/4"	785 + 2 CL	4.997 m	785 + 2 CL	4.997 m	785 + 2 CL	4.997 m
8.000	-	623 + 2 CL	5.000 m	623 + 2 CL	5.000 m	623 + 2 CL	5.000 m
9.525	3/8"	523 + 2 CL	5.001 m	523 + 2 CL	5.001 m	523 + 2 CL	5.001 m
12.700	1/2"	391 + 2 CL	4.991 m	391 + 2 CL	4.991 m	391 + 2 CL	4.991 m
15.875	5/8"	313 + 2 CL	5.001 m	313 + 2 CL	5.001 m	313 + 2 CL	5.001 m
19.050	3/4"	261 + 2 CL	5.010 m	261 + 2 CL	5.010 m	261 + 2 CL	5.010 m
25.400	1"	195 + 2 CL	5.004 m	195 + 2 CL	5.004 m	195 + 2 CL	5.004 m
31.750	1 1/4"	155 + 2 CL	4.985 m	155 + 2 CL	4.985 m	155 + 2 CL	4.985 m
38.100	1 1/2"	129 + 2 CL	4.991 m	129 + 2 CL	4.991 m	129 + 2 CL	4.991 m
44.450	1 3/4"	111 + 2 CL	5.023 m	111 + 2 CL	5.023 m	111 + 2 CL	5.023 m
50.800	2"	97 + 2 CL	5.029 m	97 + 2 CL	5.029 m	97 + 2 CL	5.029 m
57.150	2 1/4"	85 + 2 CL	4.972 m	85 + 2 CL	4.972 m	85 + 2 CL	4.972 m
63.500	2 1/2"	77 + 2 CL	5.017 m	77 + 2 CL	5.017 m	77 + 2 CL	5.017 m
76.200	3"	63 + 2 CL	4.953 m	63 + 2 CL	4.953 m	63 + 2 CL	4.953 m

### Box (feet)

Pitch		Simplex		Duplex		Triplex	
		Content: feet including 1 CL		Content: feet including 1 CL		Content: feet including 1 CL	
inch	mm	Links	Length	Links	Length	Links	Length
1/4"	6.350	479 + 1	10 ft	479 + 1	10 ft	479 + 1	10 ft
3/8"	9.525	319 + 1	10 ft	319 + 1	10 ft	319 + 1	10 ft
1/2"	12.700	239 + 1	10 ft	239 + 1	10 ft	239 + 1	10 ft
5/8"	15.875	191 + 1	10 ft	191 + 1	10 ft	191 + 1	10 ft
3/4"	19.050	159 + 1	10 ft	159 + 1	10 ft	159 + 1	10 ft
1"	25.400	119 + 1	10 ft	119 + 1	10 ft	119 + 1	10 ft
1 1/4"	31.750	95 + 1	10 ft	95 + 1	10 ft	95 + 1	10 ft
1 1/2"	38.100	79 + 1	10 ft	79 + 1	10 ft	79 + 1	10 ft
1 3/4"	44.450	69 + 1	10 ft	69 + 1	10 ft	69 + 1	10 ft
2"	50.800	59 + 1	10 ft	59 + 1	10 ft	59 + 1	10 ft
2 1/2"	63.500	49 + 1	10 ft	49 + 1	10 ft	49 + 1	10 ft

## Accessories

### Connecting links for roller chains



## Packing units – individual components

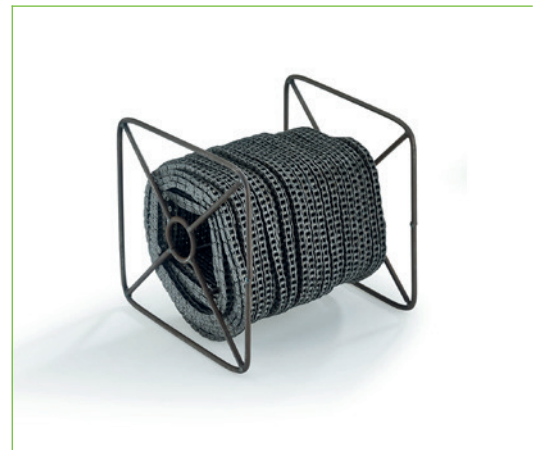
Packaging of the individual components													
Pitch		Simplex				Duplex				Triplex			
mm	inch	CL	PL	OL	OLD	CL	PL	OL	OLD	CL	PL	OL	OLD
6.000	–	50	50	50	50	50	50	–	–	–	–	–	–
6.350	¼"	50	50	50	50	50	50	50	50	50	50	50	–
8.000	–	50	50	50	50	50	50	50	50	50	50	50	–
9.525	⅜"	50	50	50	50	50	50	50	50	50	50	50	50
12.700	½"	50	50	50	25	25	25	25	25	25	25	25	25/10
15.875	⅝"	50	50	50	20	25	25	20	10	20	20	20	10
19.050	¾"	25	25	25	15	15	15	15	10	15	10	10	5
25.400	1"	20	20	20	10	10	10	10	5	5	5	5	5
31.750	1 ¼"	20	20	20	10	10	10	10	5	5	5	5	–
38.100	1 ½"	10	10	10	–	5	5	5	–	5	5	5	–
44.450	1 ¾"	5	5	5	–	5	5	5	–	5	5	5	–
50.800	2"	5	5	5	–	5	5	5	–	5	5	5	–
57.150	2 ¼"	5	5	5	–	5	5	5	–	5	5	5	–
63.500	2 ½"	5	5	5	–	5	5	5	–	5	5	5	–
76.200	3"	5	5	5	–	5	5	5	–	5	5	5	–

## Reels

### Standard length

Reels			
Pitch		Simplex roller chains	
mm	inch	meters	feet
6.000	–	76.2 / 152.4	250/500
6.350	¼"	76.2 / 152.4	250/500
8.000	–	76.2 / 152.4	250/500
9.525	⅜"	76.2 / 152.4	250/500
12.700	½"	76.2	250
15.875	⅝"	30.48	100
19.050	¾"	30.48	100
25.400	1"	15.24 / 50	50/164
31.750	1 ¼"	30.48	100
38.100	1 ½"	9.144	30

» Connecting links per reel = 1 piece



## Your global contact

**KettenWulf Betriebs GmbH**  
Zum Hohenstein 15  
D-59889 Eslohe-Kückelheim  
Germany  
T +49 (0) 2973.801 0  
F +49 (0) 2973.801 228  
service@kettenwulf.com

**KettenWulf GmbH**  
Division Ferlacher Förderketten  
A-9163 Unterbergen 25  
Austria  
T +43 (0) 4227.25 27  
F +43 (0) 4227.35 94  
austria@kettenwulf.com

**Hangzhou Wulf Chain Co. Ltd.**  
40 Tangning Road, Yunhe Town  
Yuhang District  
311102 Hangzhou  
P.R. of China  
T +86 (0) 571.861 899 00  
F +86 (0) 571.861 899 50  
china@kettenwulf.com

**KettenWulf, Inc.**  
322 Thornton Road  
Suite 101  
Lithia Springs, GA 30122  
USA  
T +1 (0) 678.4330 210  
F +1 (0) 678.4330 215  
usa@kettenwulf.com

**KettenWulf**  
Representative Office Poland  
ul. Ogrodowa 34 B\ 4  
PL-65-001 Zielona Góra  
Poland  
T +48 (0) 68.325 43 37  
F +48 (0) 68.325 43 37  
poland@kettenwulf.com

**KettenWulf Betriebs GmbH**  
Liaison Office Indien  
A-104, Samarth Carina,  
Near Aditya Birla Hospital,  
Thergaon  
Pune-411033  
India  
M +91 (0) 98.905 031 64  
india@kettenwulf.com

**KettenWulf Betriebs GmbH**  
Liaison Office Turkey  
Varyap Meridian Grand Tower  
A-Block No: 58  
34746 Atasehir - Istanbul  
Turkey  
T +90 (0) 216.510 47 94  
F +90 (0) 216.510 47 94  
turkey@kettenwulf.com

**KettenWulf Pty Ltd**  
Level 6, 8 Spring Street  
Sydney NSW 2000  
Australia  
T +61 (0) 282.960 498  
F +61 (0) 282.960 411  
australia@kettenwulf.com

**KettenWulf NV**  
Business Centre  
Esplanade 1/85  
1020 Brussels  
Belgium  
T +32 (0) 2 486 6516  
service@kettenwulf.com

**KettenWulf Canada Inc.**  
480 University Avenue  
Suite 1500  
Toronto, ON M5G 1V2  
Canada  
T +1 (0) 416.598 7072  
canada@kettenwulf.com