



Martin MPC[®]

Poly Chain[®] - Pulleys

***High Power
Transmission
Solutions***

WARNING & SAFETY REMINDER

Safety must be considered a basic factor in machinery operation at all times. Most accidents are the result of carelessness or negligence. All rotating power transmission products are potentially dangerous and must be guarded by the contractor, installer, purchaser, owner, and user as required by applicable laws, regulations, standards, and good safety practice. Additional specific information must be obtained from other sources including the latest editions of ISO 1940-1 (2003).

It is the responsibility of the contractor, installer, purchaser, owner, and user to install, maintain, and operate the parts or components manufactured and supplied by *Martin* Sprocket & Gear, Inc., in such a manner as to comply with the Williams-Steiger Occupational Safety Act and with all state and local laws, ordinances, regulations, and the American National Standard Institute Safety Code.

CAUTION

Guards, access doors, and covers must be securely fastened before operating any equipment.

If parts are to be inspected, cleaned, observed, or general maintenance performed, the motor driving the part or components is to be locked out electrically in such a manner that it cannot be started by anyone, however remote from the area. Failure to follow these instructions may result in personal injury or property damage.

WARNING

NOTE: CATALOG DIMENSIONS

Every effort is made to keep all catalog dimensions and styles current in the catalog, however from time to time, it is necessary because of manufacturing changes to alter stock products dimensionally.

If any stock product dimension or style shown in this catalog is critical to your application please consult factory for certification.

MPC® Synchronous Pulleys



Bushing Options

PB Minimum Plain Bore
No prefix Taper Bushed

Belt Pitch

8mm
14mm

Number of Teeth "S" identifies it as an MPC®

PB 8MX 22S 12 - TB

Bushing Options

TB 1008, 1108... 120100
QD JA, SH, SDS...

Belt Width (mm)

12, 21, 36, 62
20, 37, 68, 90, 125

Introducing our newest synchronous pulleys.

The addition of our MPC® pulleys line makes Martin your one-stop-shop for all your synchronous pulleys needs. Match your pulleys to your favorite belt.

MPC® Synchronous Pulleys are available in your desired configuration.

- Available in 8mm and 14mm pitches.
- Belt widths:
 12mm, 21mm, 36mm, 62mm (8mm pitch)
 20mm, 37mm, 68mm, 90mm, 125mm (14mm pitch)
- Available in TB or other special adapters.
- Special diameters and widths, as well as special materials, are also available.

MPC® Pulleys

8mm

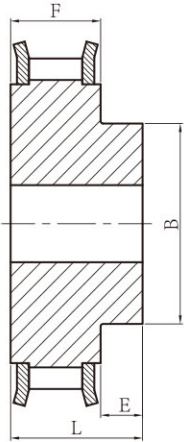

Type 1F

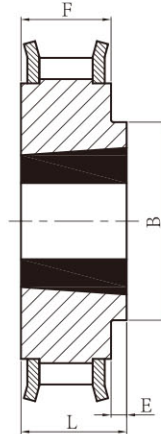

Type 2F

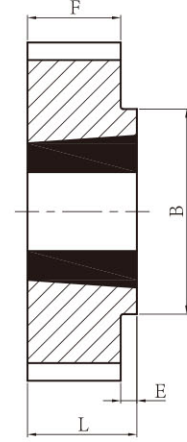

Type 2

8mm Pitch — 12mm Wide Belt

No. of Teeth	Catalog Number	Bore	Pitch Diameter	Diameter		Type	Max Bore	Dimensions						
				O.D.	Max Flange O.D.			A	B	E	F	K	L	M
MBP 8mm Pitch, 12mm (0.47 in.) Wide Belts (8M -12)														
22	PB8MX22S12E	12	56.02	54.42	60	1F	28	-	43	10	20	-	30	-
Taper Bushed 8mm Pitch, 12mm (0.47 in.) Wide Belts (8M -12)														
25	8MX25S12E-1108	1108	63.66	62.06	70	2F	28	-	49	2	20	-	22	-
28	8MX28S12E-1108	1108	71.30	69.70	75	2F	28	-	56	2	20	-	22	-
30	8MX30S12E-1210	1210	76.39	74.79	82.5	2F	32	-	60	5	20	-	25	-
32	8MX32S12E-1610	1610	81.49	79.89	87	2F	42	-	66	5	20	-	25	-
34	8MX34S12E-1610	1610	86.58	84.98	91	2F	42	-	69	5	20	-	25	-
36	8MX36S12E-1610	1610	91.67	90.07	97	2F	42	-	76	5	20	-	25	-
38	8MX38S12E-1610	1610	96.77	95.17	102	2F	42	-	78	5	20	-	25	-
40	8MX40S12E-1610	1610	101.86	100.26	106	2F	42	-	85	5	20	-	25	-
45	8MX45S12E-2012	2012	114.59	112.99	120	2F	50	-	92	12	20	-	32	-
48	8MX48S12E-2012	2012	112.23	120.63	128	2F	50	-	103	12	20	-	32	-
50	8MX50S12E-2012	2012	127.32	125.72	135	2F	50	-	104	12	20	-	32	-
56	8MX56S12E-2012	2012	142.60	141.00	150	2F	50	-	104	12	20	-	32	-
60	8MX60S12E-2012	2012	152.79	151.19	158	2F	50	-	111	12	20	-	32	-
64	8MX64S12E-2012	2012	162.97	161.37	168	2F	50	-	111	12	20	-	32	-
75	8MX75S12E-2012	2012	190.99	189.39	-	2	50	-	111	12	20	-	32	-
80	8MX80S12E-2012	2012	203.72	202.12	-	2	50	-	111	12	20	-	32	-
90	8MX90S12E-2012	2012	229.18	227.58	-	2	50	-	111	12	20	-	32	-

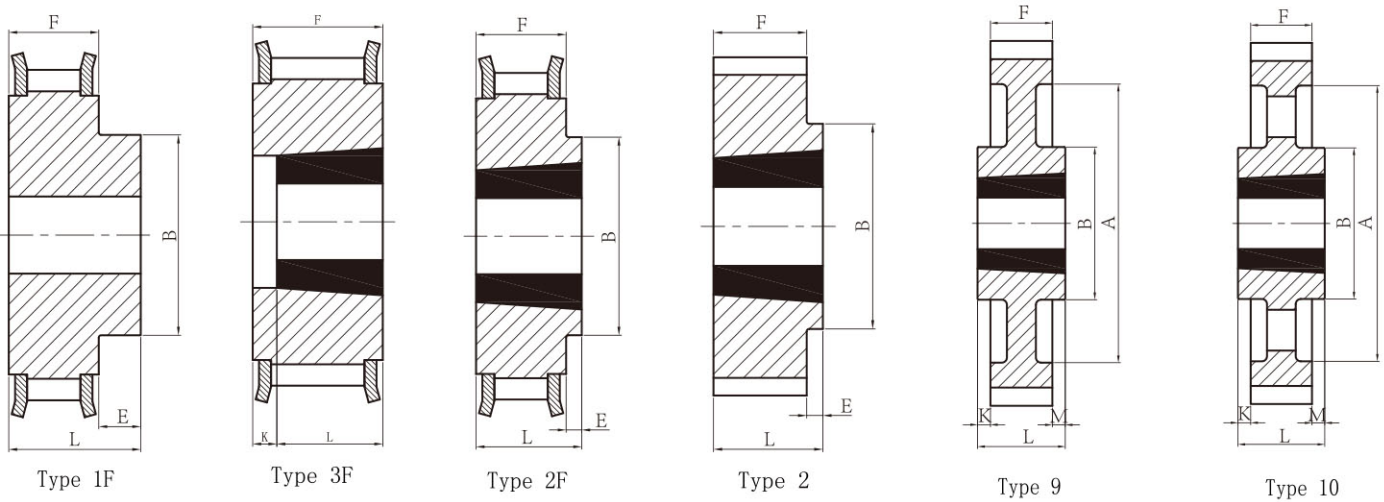

8mm Pitch — 21mm Wide Belt

No. of Teeth	Catalog Number	Bore	Pitch Diameter	Diameter		Type	Max Bore	Dimensions						
				O.D.	Max Flange O.D.			A	B	E	F	K	L	M
MBP 8mm Pitch, 21mm (0.83 in.) Wide Belts (8M -21)														
22	PB8MX22S21E	12	56.02	54.42	60	1F	28	-	43	12	30	-	42	-
Taper Bushed 8mm Pitch, 21mm (0.83 in.) Wide Belts (8M -21)														
25	8MX25S21E-1108	1108	63.66	62.06	70	3F	28	-	-	-	30	8	22	-
28	8MX28S21E-1210	1210	71.30	69.70	75	3F	32	-	-	-	30	5	25	-
30	8MX30S21E-1210	1210	76.39	74.79	82.5	3F	32	-	-	-	30	5	25	-
32	8MX32S21E-1610	1610	81.49	79.89	87	3F	42	-	-	-	30	5	25	-
34	8MX34S21E-1610	1610	86.58	84.98	91	3F	42	-	-	-	30	5	25	-
36	8MX36S21E-1610	1610	91.67	90.07	97	3F	42	-	-	-	30	5	25	-
38	8MX38S21E-1610	1610	96.77	95.17	102	3F	42	-	-	-	30	5	25	-
40	8MX40S21E-1610	1610	101.86	100.26	106	3F	42	-	-	-	30	5	25	-
45	8MX45S21E-2012	2012	114.59	112.99	120	2F	50	-	92	2	30	-	32	-
48	8MX48S21E-2012	2012	122.23	120.63	128	2F	50	-	103	2	30	-	32	-
50	8MX50S21E-2012	2012	127.32	125.72	135	2F	50	-	104	2	30	-	32	-
56	8MX56S21E-2012	2012	142.60	141.00	150	2F	50	-	111	2	30	-	32	-
60	8MX60S21E-2517	2517	152.79	151.19	158	2F	60	-	124	15	30	-	45	-
64	8MX64S21E-2517	2517	162.97	161.37	168	2F	60	-	124	15	30	-	45	-
75	8MX75S21E-2517	2517	190.99	189.39	-	2	60	-	124	15	30	-	45	-
80	8MX80S21E-2517	2517	203.72	202.12	-	2	60	-	124	15	30	-	45	-
90	8MX90S21E-2517	2517	229.18	227.58	-	9	60	198	124	-	30	7.5	45	7.5
112	8MX112S21E-2517	2517	285.21	283.61	-	9	60	253	124	-	30	7.5	45	7.5
140	8MX140S21E-3020	3020	356.51	354.91	-	10	75	324	150	-	30	10.5	51	10.5

MPC® Pulleys 8mm

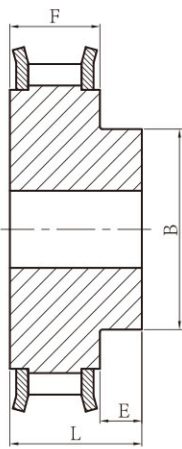

Type 1F

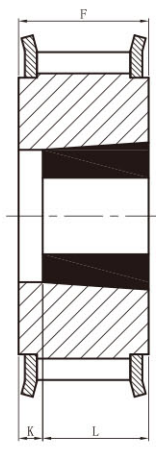

Type 3F

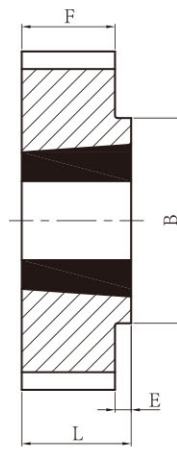

Type 2

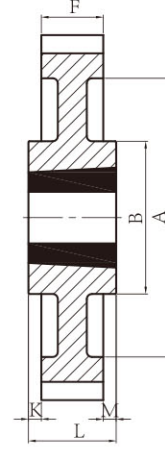

Type 9

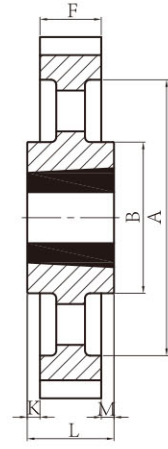

Type 10

8mm Pitch — 36mm Wide Belt

No. of Teeth	Catalog Number	Bore	Pitch Diameter	Diameter		Type	Max Bore	Dimensions						
				O.D.	Max Flange O.D.			A	B	E	F	K	L	M
MBP 8mm Pitch, 36mm (1.42 in.) Wide Belts (8M -36)														
25	PB8MX25S36E	12	63.66	62.06	70	1F	32	-	49	10	45	-	55	-
Taper Bushed 8mm Pitch, 36mm (1.42 in.) Wide Belts (8M -36)														
28	8MX28S36E-1210	1210	71.30	69.70	75	3F	32	-	-	-	45	-	-	-
30	8MX30S36E-1610	1610	76.39	74.79	82.50	3F	42	-	-	-	45	-	-	-
32	8MX32S36E-1610	1610	81.49	79.89	87	3F	42	-	-	-	45	-	-	-
34	8MX34S36E-1610	1610	86.58	84.98	91	3F	42	-	-	-	45	-	-	-
36	8MX36S36E-1610	1610	91.67	90.07	97	3F	42	-	-	-	45	-	-	-
38	8MX38S36E-1610	1610	96.77	95.17	102	3F	42	-	-	-	45	-	-	-
40	8MX40S36E-2012	2012	101.86	100.26	106	3F	50	-	-	-	45	-	-	-
45	8MX45S36E-2012	2012	114.59	112.99	120	3F	50	-	-	-	45	-	-	-
48	8MX48S36E-2012	2012	122.23	120.63	128	3F	50	-	-	-	45	-	-	-
50	8MX50S36E-2012	2012	127.32	125.72	135	3F	50	-	-	-	45	-	-	-
56	8MX56S36E-2517	2517	142.60	141.00	150	3F	60	-	-	-	45	-	-	-
60	8MX60S36E-2517	2517	152.79	151.19	158	3F	60	-	-	-	45	-	-	-
64	8MX64S36E-2517	2517	161.97	161.37	168	3F	60	-	-	-	45	-	-	-
75	8MX75S36E-3020	3020	190.99	189.39	-	2	75	-	150	6	45	-	51	-
80	8MX80S36E-3020	3020	203.72	202.12	-	2	75	-	150	6	45	-	51	-
90	8MX90S36E-3020	3020	229.18	227.58	-	9	75	197	150	-	45	3	51	3
112	8MX112S36E-3020	3020	285.21	283.61	-	9	75	253	150	-	45	3	51	3
140	8MX140S36E-3020	3020	356.51	354.91	-	10	75	324	150	-	45	3	51	3
168	8MX168S36E-3525	3525	427.81	426.21	-	10	100	396	198	-	45	10	65	10
192	8MX192S36E-3525	3525	488.92	487.32	-	10	100	457	198	-	45	10	65	10

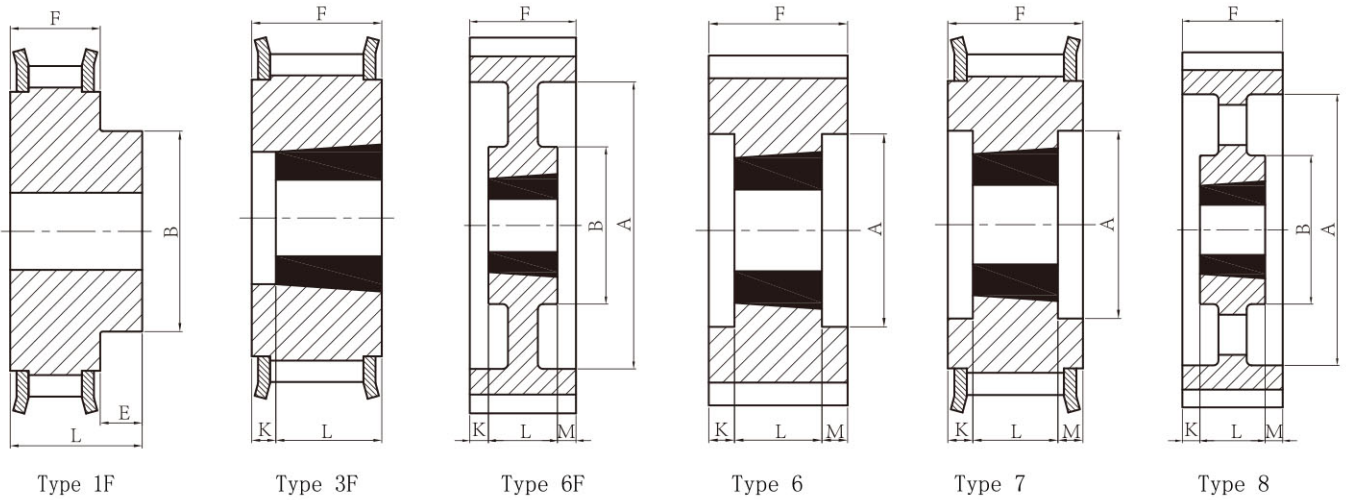

8mm Pitch — 62mm Wide Belt

No. of Teeth	Catalog Number	Bore	Pitch Diameter	Diameter		Type	Max Bore	Dimensions						
				O.D.	Max Flange O.D.			A	B	E	F	K	L	M
MPB 8mm Pitch, 62mm (2.44 in.) Wide Belts (8M - 62)														
30	PB8MX30S62E	20	76.39	74.79	82.50	1F	42	-	63	12	72	-	84	-
32	PB8MX32S62E	20	81.49	79.89	87	1F	50	-	68	12	72	-	84	-
34	PB8MX34S62E	20	86.58	84.98	91	1F	55	-	69	12	72	-	84	-
36	PB8MX36S62E	20	91.67	90.07	97	1F	60	-	76	12	72	-	84	-
38	PB8MX38S62E	20	96.77	95.17	102	1F	60	-	78	12	72	-	84	-
Taper Bushed 8mm Pitch, 62mm (2.44 in.) Wide Belts (8M - 62)														
40	8MX40S62E-2012	2012	101.86	100.26	106	3F	50	-	-	-	72	-	-	-
45	8MX45S62E-2012	2012	114.59	112.99	120	3F	50	-	-	-	72	-	-	-
48	8MX48S62E-2517	2517	122.23	120.63	128	3F	60	-	-	-	72	-	-	-
50	8MX50S62E-2517	2517	127.32	125.72	135	3F	60	-	-	-	72	-	-	-
56	8MX56S62E-2517	2517	142.60	141.00	150	6F	60	111	-	-	72	13.5	45	13.5
60	8MX60S62E-2517	2517	152.79	151.19	158	6F	60	121	-	-	72	13.5	45	13.5
64	8MX64S62E-2517	2517	162.97	161.37	168	6F	60	131	-	-	72	13.5	45	13.5
75	8MX75S62E-3020	3020	190.99	189.39	-	6	75	159	-	-	72	10.5	51	10.5
80	8MX80S62E-3020	3020	203.72	202.12	-	6	75	172	-	-	72	10.5	51	10.5
90	8MX90S62E-3020	3020	229.18	227.58	-	6	75	197	-	-	72	10.5	51	10.5
112	8MX112S62E-3020	3020	285.21	283.61	-	7	75	253	150	-	72	10.5	51	10.5
140	8MX140S62E-3525	3525	356.51	354.91	-	7	100	324	198	-	72	3.5	65	3.5
168	8MX168S62E-3525	3525	427.81	426.21	-	8	100	396	198	-	72	3.5	65	3.5
192	8MX192S62E-3525	3525	488.92	487.32	-	8	100	457	198	-	72	3.5	65	3.5

MPC® Pulleys

14mm

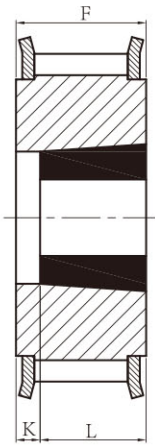

Type 3F

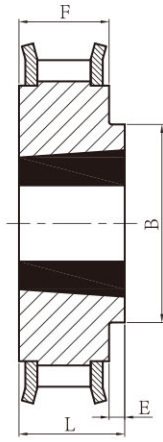

Type 2F

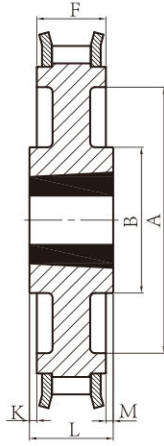

Type 9F

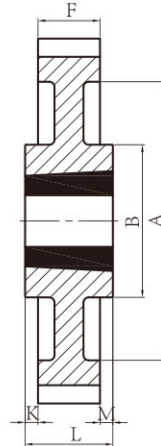

Type 9

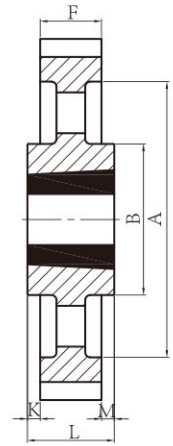

Type 10

14mm Pitch — 20mm Wide Belt

No. of Teeth	Catalog Number	Bore	Pitch Diameter	Diameter		Type	Max Bore	Dimensions						
				O.D.	Max Flange O.D.			A	B	E	F	K	L	M
Tapered Bushed 14mm Pitch, 20mm (.826 in.) Wide Belt (14M-20)														
28	14MX28S20E-2012	2012	124.78	121.98	128	3F	50	-	-	-	33	-	-	-
30	14MX30S20E-2012	2012	133.69	130.89	138	3F	50	-	-	-	33	-	-	-
32	14MX32S20E-2012	2012	142.60	139.80	154	3F	50	-	-	-	33	-	-	-
34	14MX34S20E-2517	2517	151.52	148.72	160	2F	60	-	117	12	33	-	45	-
36	14MX36S20E-2517	2517	160.43	157.63	168	2F	60	-	117	12	33	-	45	-
38	14MX38S20E-2517	2517	169.34	166.54	183	2F	60	-	117	12	33	-	45	-
40	14MX40S20E-2517	2517	178.25	175.45	188	2F	60	-	117	12	33	-	45	-
44	14MX44S20E-3020	3020	196.08	193.28	211	2F	75	-	144	18	33	-	51	-
48	14MX48S20E-3020	3020	213.90	211.11	226	2F	75	-	144	18	33	-	51	-
50	14MX50S20E-3020	3020	222.82	220.02	240	2F	75	-	144	18	33	-	51	-
56	14MX56S20E-3020	3020	249.55	246.76	256	9F	75	207	144	-	33	9	51	9
60	14MX60S20E-3020	3020	267.38	264.58	-	9	75	224	159	-	33	9	51	9
64	14MX64S20E-3020	3020	285.21	282.41	-	9	75	242	159	-	33	9	51	9
72	14MX72S20E-3020	3020	320.86	318.06	-	9	75	278	159	-	33	9	51	9
80	14MX80S20E-3020	3020	356.51	353.71	-	9	75	314	159	-	33	9	51	9
90	14MX90S20E-3020	3020	401.07	398.27	-	10	75	360	159	-	33	9	51	9
112	14MX112S20E-3020	3020	499.11	496.31	-	10	75	456	159	-	33	9	51	9
140	14MX140S20E-3525	3020	623.89	621.09	-	10	75	581	159	-	33	9	51	9

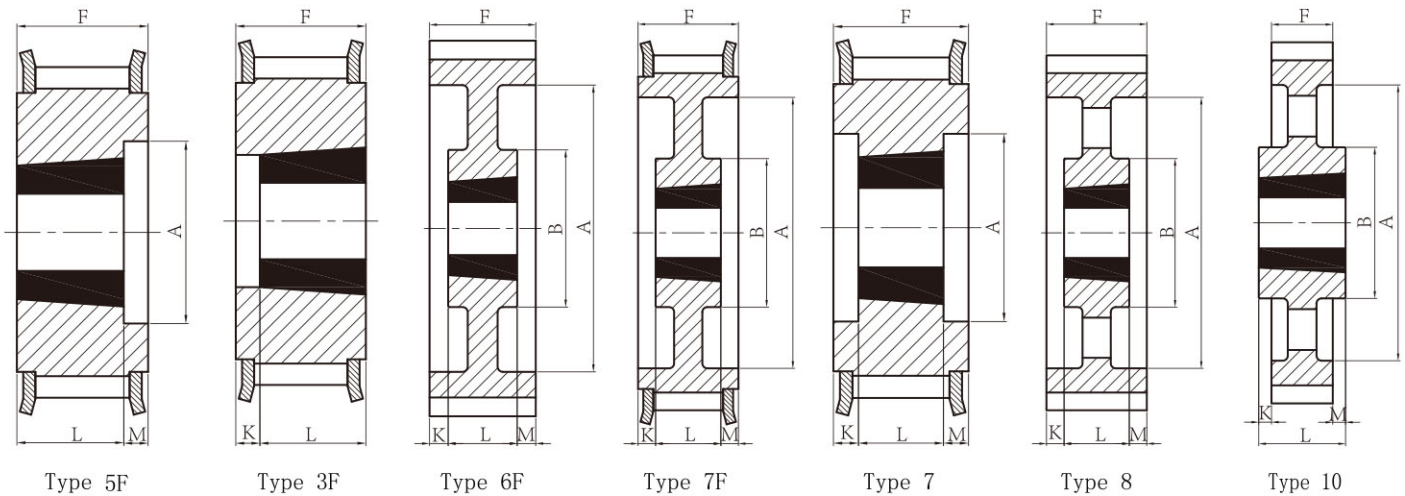

14mm Pitch —37mm Wide Belt

No. of Teeth	Catalog Number	Bore	Pitch Diameter	Diameter		Type	Max Bore	Dimensions						
				O.D.	Max Flange O.D.			A	B	E	F	K	L	M
Taper Bushed 14mm Pitch, 37mm (1.46 in.) Wide Belt (14M-37)														
28	14MX28S37E-2012	2012	124.98	121.98	128	5F	50	88	-	-	51	-	32	19
30	14MX30S37E-2517	2517	133.69	130.89	138	6F	60	98	-	-	51	3	45	3
32	14MX32S37E-2517	2517	142.60	139.80	154	6F	60	100	-	-	51	3	45	3
34	14MX34S37E-2517	2517	151.52	148.72	160	6F	60	109	-	-	51	3	45	3
36	14MX36S37E-2517	2517	160.43	157.63	168	5F	60	117	-	-	51	-	45	6
38	14MX38S37E-2517	2517	169.34	166.54	183	5F	60	126	-	-	51	-	45	6
40	14MX40S37E-2517	2517	178.25	175.45	188	5F	60	135	-	-	51	-	45	6
44	14MX44S37E-3020	3020	196.08	193.28	211	3F	75	-	-	-	51	-	-	-
48	14MX48S37E-3020	3020	213.90	211.11	226	3F	75	-	-	-	51	-	-	-
50	14MX50S37E-3020	3020	222.82	220.02	240	3F	75	-	-	-	51	-	-	-
56	14MX56S37E-3020	3020	249.55	246.76	256	7F	75	207	144	-	51	0	51	0
60	14MX60S37E-3020	3020	267.38	264.58	-	7	75	224	159	-	51	0	51	0
64	14MX64S37E-3020	3020	285.21	282.41	-	7	75	242	159	-	51	0	51	0
72	14MX72S37E-3020	3020	320.86	318.06	-	7	75	278	159	-	51	0	51	0
80	14MX80S37E-3020	3020	356.51	353.71	-	7	75	314	159	-	51	0	51	0
90	14MX90S37E-3020	3020	401.07	398.27	-	8	75	360	159	-	51	0	51	0
112	14MX112S37E-3020	3020	499.11	496.31	-	8	75	456	159	-	51	0	51	0
140	14MX140S37E-3525	3525	623.89	621.09	-	10	100	581	206	-	51	7	65	7
168	14MX168S37E-3525	3525	748.66	745.87	-	10	100	706	206	-	51	7	65	7
192	14MX192S37E-4030	4030	855.61	852.82	-	10	115	812	215	-	51	12.5	76	12.5

MPC® Pulleys

14mm

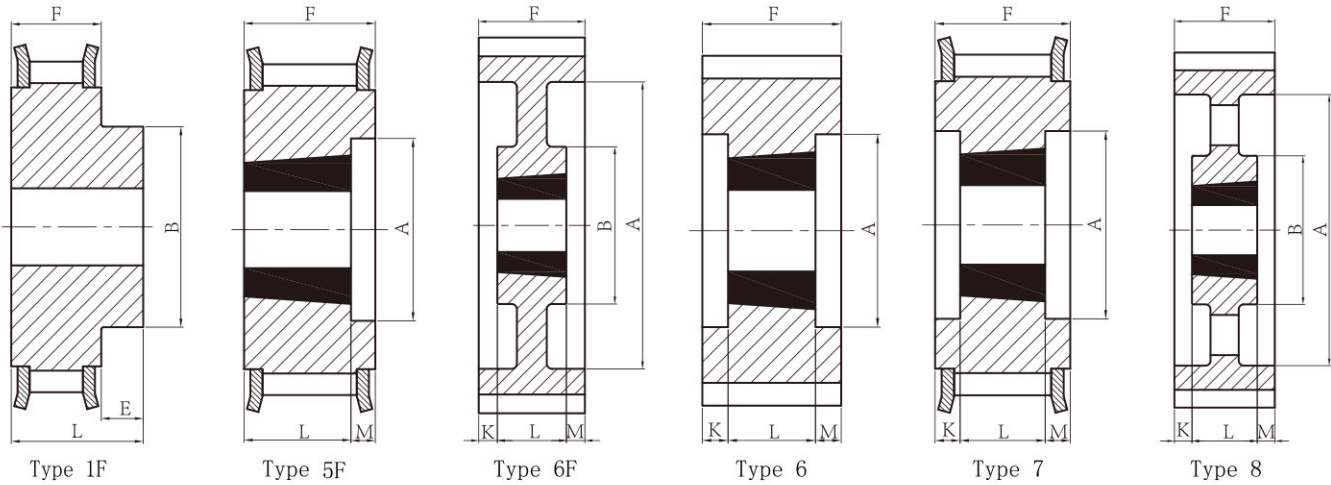

14mm Pitch — 68mm Wide Belt

No. of Teeth	Catalog Number	Bore	Pitch Diameter	Diameter		Type	Max Bore	Dimensions						
				O.D.	Max Flange O.D.			A	B	E	F	K	L	M
MPB 14mm Pitch, 68mm (2.68 in.) Wide Belt (14M-68)														
34	PB14MX34S68E	40	151.52	148.72	160	1F	100	-	132	20	84	-	104	-
36	PB14MX36S68E	40	160.43	157.63	168	1F	100	-	131	20	84	-	104	-
38	PB14MX38S68E	40	169.34	166.54	183	1F	115	-	141	20	84	-	104	-
40	PB14MX40S68E	40	178.25	175.45	188	1F	125	-	156	20	84	-	104	-
Taper Bushed 14mm Pitch, 68mm (2.68 in.) Wide Belt (14M-68)														
44	14MX44S68E-3020	3020	196.08	193.28	211	6F	75	153	-	-	84	16.5	51	16.5
48	14MX48S68E-3020	3020	213.90	211.11	226	5F	75	171	-	-	84	-	51	33
50	14MX50S68E-3525	3525	222.82	220.02	240	6F	100	180	-	-	84	9.5	65	9.5
56	14MX56S68E-3525	3525	249.55	246.76	256	6F	100	207	-	-	84	9.5	65	9.5
60	14MX60S68E-3525	3525	267.38	264.58	-	6	100	224	-	-	84	9.5	65	9.5
64	14MX64S68E-3525	3525	285.21	282.41	-	6	100	242	-	-	84	9.5	65	9.5
72	14MX72S68E-3525	3525	320.86	318.06	-	7	100	278	178	-	84	9.5	65	9.5
80	14MX80S68E-3525	3525	356.51	353.71	-	7	100	314	178	-	84	9.5	65	9.5
90	14MX90S68E-3525	3525	401.07	398.27	-	8	100	360	178	-	84	9.5	65	9.5
112	14MX112S68E-3525	3525	499.11	496.31	-	8	100	456	178	-	84	9.5	65	9.5
140	14MX140S68E-3525	3525	623.89	621.09	-	8	100	581	206	-	84	9.5	65	9.5
168	14MX168S68E-3525	3525	748.66	745.87	-	8	100	706	206	-	84	9.5	65	9.5
192	14MX192S68E-4030	4030	855.61	852.82	-	8	115	812	215	-	84	4	76	4

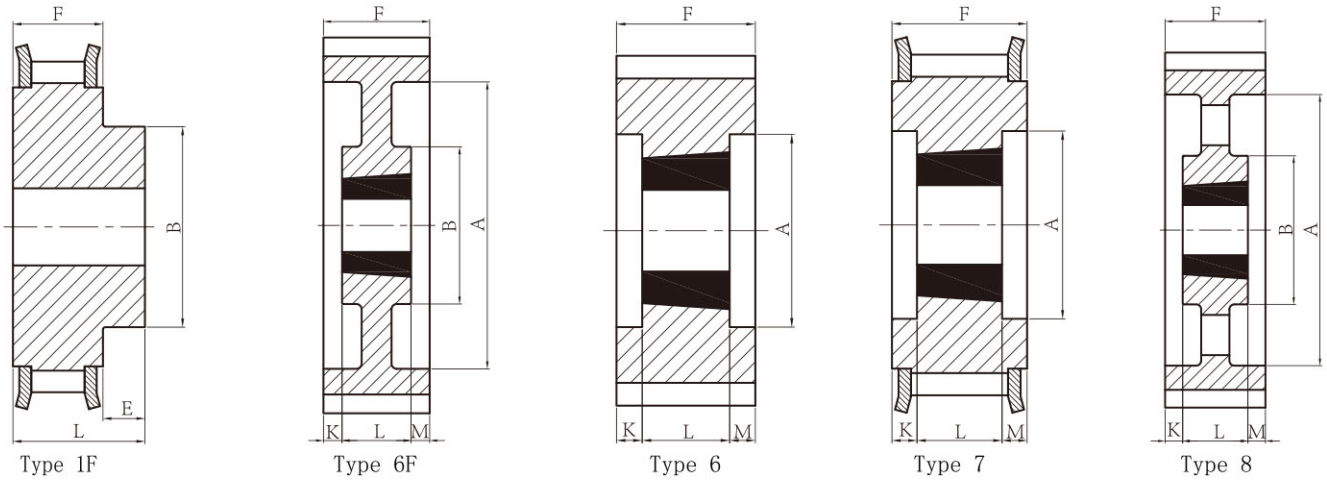

14mm Pitch — 90mm Wide Belt

No. of Teeth	Catalog Number	Bore	Pitch Diameter	Diameter		Type	Max Bore	Dimensions						
				O.D.	Max Flange O.D.			A	B	E	F	K	L	M
MPB 14mm Pitch, 90mm (3.54 in.) Wide Belt (14M-90)														
36	PB14MX36S90E	50	160.43	157.63	168	1F	110	-	131	30	106	-	136	-
38	PB14MX38S90E	50	169.34	166.50	183	1F	115	-	141	30	106	-	136	-
40	PB14MX40S90E	50	178.25	175.45	188	1F	125	-	156	30	106	-	136	-
44	PB14MX44S90E	50	196.08	193.28	211	1F	140	-	169	30	106	-	136	-
Taper Bushed 14mm Pitch, 90mm (3.54 in.) Wide Belt (14M-90)														
48	14MX48S90E-3525	3525	213.90	211.11	226	6F	100	171	-	-	106	20	66	20
50	14MX50S90E-3525	3525	222.82	220.02	240	6F	100	180	-	-	106	20	66	20
56	14MX56S90E-3525	3525	249.55	246.76	256	6F	100	207	-	-	106	20	66	20
60	14MX60S90E-3525	3525	267.38	264.58	-	6	100	224	-	-	106	20	66	20
64	14MX64S90E-3525	3525	285.21	282.41	-	6	100	242	-	-	106	20	66	20
72	14MX72S90E-3525	3525	320.86	318.06	-	7	100	278	178	-	106	20	66	20
80	14MX80S90E-4030	4030	356.51	353.71	-	7	115	314	215	-	106	15	76	15
90	14MX90S90E-4030	4030	401.07	398.27	-	7	115	360	215	-	106	15	76	15
112	14MX112S90E-4535	4535	499.11	496.31	-	8	125	456	215	-	106	8	90	8
140	14MX140S90E-4535	4535	623.89	621.09	-	8	125	581	215	-	106	8	90	8
168	14MX168S90E-5040	5040	748.66	745.87	-	8	130	706	267	-	106	2	102	2
192	14MX192S90E-5040	5040	855.61	852.82	-	8	130	812	267	-	106	2	102	2

MPC® Pulleys 14mm

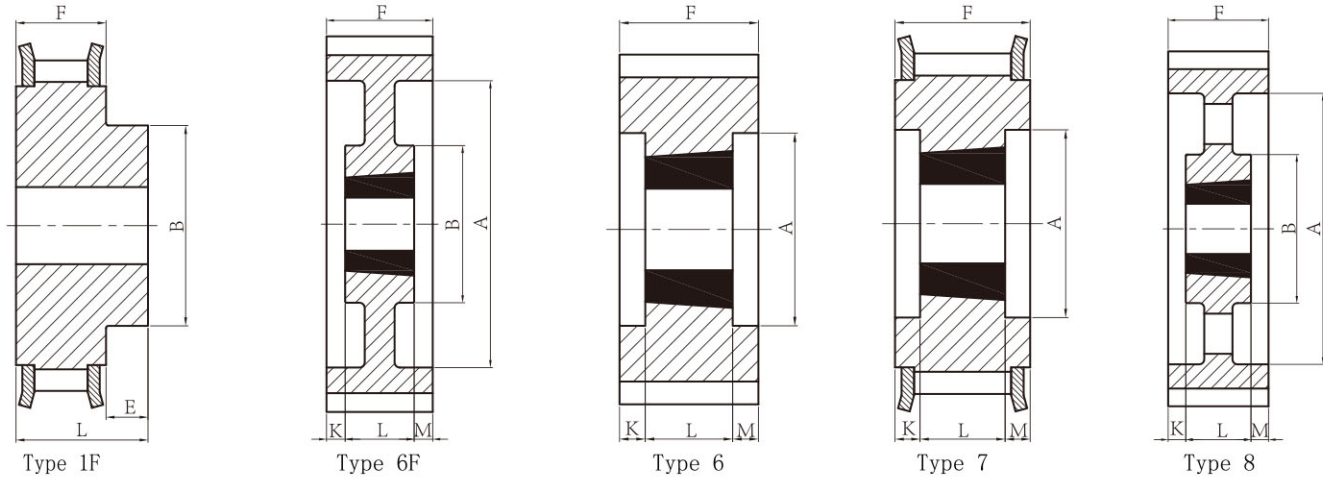

14mm Pitch — 125mm Wide Belt

No. of Teeth	Catalog Number	Bore	Pitch Diameter	Diameter		Type	Max Bore	Dimensions						
				O.D.	Max Flange O.D.			A	B	E	F	K	L	M
MPB 14mm Pitch, 125mm (4.92 in.) Wide Belt (14M-125)														
38	PB14MX38S125E	50	169.34	166.54	183	1F	115	-	141	20	141	-	161	-
40	PB14MX40S125E	50	178.25	175.45	188	1F	125	-	156	20	141	-	161	-
44	PB14MX44S125E	50	196.08	193.28	211	1F	140	-	169	20	141	-	161	-
48	PB14MX48S125E	50	213.90	211.11	226	1F	160	-	185	20	141	-	161	-
Taper Bushed 14mm Pitch, 125mm (4.92 in.) Wide Belt (14M-125)														
50	14MX50S125E-3525	3525	222.82	220.02	240	6F	100	180	-	-	141	38	65	38
56	14MX56S125E-3525	3525	249.55	246.76	256	6F	100	207	-	-	141	38	65	38
60	14MX60S125E-4030	4030	267.38	264.58	-	6	115	224	-	-	141	32.5	76	32.5
64	14MX64S125E-4030	4030	285.21	282.41	-	6	115	242	-	-	141	32.5	76	32.5
72	14MX72S125E-4030	4030	320.86	318.06	-	7	115	278	215	-	141	32.5	76	32.5
80	14MX80S125E-4030	4030	356.51	353.71	-	7	115	314	215	-	141	32.5	76	32.5
90	14MX90S125E-4030	4030	401.07	398.27	-	7	115	360	215	-	141	32.5	76	32.5
112	14MX112S125E-4535	4535	499.11	496.31	-	8	125	456	215	-	141	26	89	26
140	14MX140S125E-4535	4535	623.89	621.09	-	8	125	581	215	-	141	26	89	26
168	14MX168S125E-5040	5040	748.66	745.87	-	8	125	706	267	-	141	19.5	102	19.5
192	14MX192S125E-5040	5040	855.61	852.82	-	8	125	812	267	-	141	19.5	102	19.5

Warning & Safety Reminder



WARNING & SAFETY REMINDER

Safety must be considered a basic factor in machinery operation at all times. Most accidents are the result of carelessness or negligence. All rotating power transmission products are potentially dangerous and must be guarded by the contractor, installer, purchaser, owner, and user as required by applicable laws, regulations, standards, and good safety practice. Additional specific information must be obtained from other sources including the latest editions of ISO 1940-1 (2003).

It is the responsibility of the contractor, installer, purchaser, owner, and user to install, maintain, and operate the parts or components manufactured and supplied by *Martin* Sprocket & Gear, Inc., in such a manner as to comply with the Williams-Steiger Occupational Safety Act and with all state and local laws, ordinances, regulations, and the American National Standard Institute Safety Code.

CAUTION

Guards, access doors, and covers must be securely fastened before operating any equipment.

If parts are to be inspected, cleaned, observed, or general maintenance performed, the motor driving the part or components is to be locked out electrically in such a manner that it cannot be started by anyone, however remote from the area. Failure to follow these instructions may result in personal injury or property damage.

WARNING

NOTE: CATALOG DIMENSIONS

Every effort is made to keep all catalog dimensions and styles current in the catalog, however from time to time, it is necessary because of manufacturing changes to alter stock products dimensionally.

If any stock product dimension or style shown in this catalog is critical to your application please consult factory for certification.



Tel. 973 71 18 84 - Fax 973 71 18 09
e-mail: lindis@lindis.es
www.lindis.com

Pol. Ind. Golparc - Av, d'Europa 18-20
25241 Golmés (Lleida)